



CONSERVATION BY DESIGN
A Larson-Juhl Company



BY APPOINTMENT
TO HER MAJESTY QUEEN ELIZABETH II
SUPPLIERS OF CONSERVATION STORAGE,
EQUIPMENT AND DISPLAY PRODUCTS
CONSERVATION BY DESIGN LIMITED
BEDFORD



info@cami-nv.com

CATALOGUE VOLUME 2

Welcome

Welcome to the new Conservation By Design (CXD) catalogue, offering a comprehensive range of solutions for conservation professionals, which has been developed in collaboration with conservators from around the world.

Inside, you'll find a wider choice of products than ever before, including many new items to our range sourced from across the globe. We work in partnership with experts from leading museums, galleries and archives to develop equipment to meet your every conservation need. We welcome insight and ideas from our customers and, if you require something that you can't find in this catalogue, please get in touch so we can see how we may be able to help you.



About Us

Since 1992, conservators from museums, libraries and archives worldwide have turned to Conservation By Design (CXD) for our comprehensive range of high-quality conservation storage and display equipment. Our customers today still enjoy the same core values at the heart of the CXD business, which was established by founder, Stuart Welch, as an ethical company with a positive philosophy dedicated to creative, open-minded design and products that would answer the needs of all areas of cultural preservation.

In 2007 CXD was acquired by Arqadia, the UK's leading supplier to the art and framing market and became part of the international Larson Juhl group. Now, as part of a global network of conservation companies, we collaborate with conservators the world over to bring our customers the very latest conservation product innovations. This catalogue includes many new products, which have been developed with conservators overseas, including a number introduced by our French sister company, Stouls. Our international presence means we can harness global expertise and supply chains to offer you the widest choice of conservation equipment at competitive prices.

In July 2013, CXD strengthened its UK portfolio further with the acquisition of Armour Systems, enabling us to offer a market-leading range of high-quality museum display cases and cabinets, manufactured in the UK to complement our existing product line-up.

Expertise

Our in-house creative engineering capabilities mean we are able to respond quickly to customers' needs with tailor-made product solutions. At our factories in Bedford, CXD design and manufacture the world's largest range of acid-free archival storage boxes as well as a growing range of conservation-grade polyester pockets.

In addition, the CXD engineering facility designs and manufactures a wide range of storage furniture including Planorama®, a unique, anodised aluminium drawer storage and display system. Each unit is bespoke and hand-built to almost any size or configuration. Our partnership with Armour Systems also enables us to offer a market-leading range of high-quality museum display cases and cabinets manufactured in the UK.





WE CREATE WE MAKE WE STOCK

With over 7000 products and a bespoke fabrication service, whatever you need, CXD have the answer or will find it.

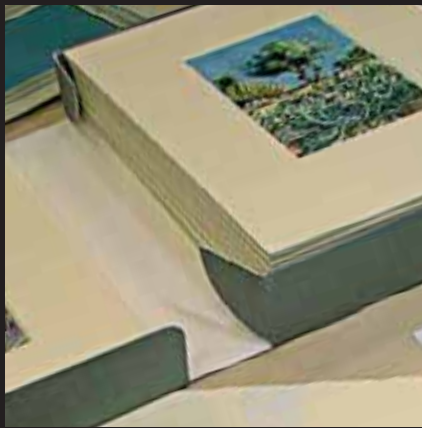

Commitment

Conservation By Design brings together a thorough understanding of conservation requirements and creative engineering to make sure that, from initial enquiry through to completion, we exceed our customers' expectations. Whatever your requirements, CXD believe in delivering high-quality conservation products and a first-class service, ensuring that all customers are given the time, care and attention they deserve.

We're very proud to be Holder of the Royal Warrant by appointment to her Majesty the Queen, a mark of our unfailing commitment to quality craftsmanship.



BY APPOINTMENT
TO HER MAJESTY QUEEN ELIZABETH II
SUPPLIERS OF CONSERVATION STORAGE,
EQUIPMENT AND DISPLAY PRODUCTS
CONSERVATION BY DESIGN LIMITED
BEDFORD

Showroom

See a selection of products available by arranging an appointment to visit the CXD showroom, based at Arqadia's offices on Wolseley Road, Bedford. It is open Monday to Friday from 9am to 5pm. To arrange a visit or one-to-one consultation, please email showroom@cxdltd.com

Testing

In the 1980s, researchers at the Rochester Institute of Technology (RIT) developed the Photographic Activity Test (PAT), which became an ISO standard and remains the trusted method for determining the safety of a material used in photo storage or display. In 1985, the Image Permanence Institute (IPI) at RIT was formed and continued to improve the accuracy of the test, expanding its scope to include plastics, adhesives, inks and other materials.

Wherever you see the PAT icon in the catalogue, you can rest assured that this item or its component parts have been independently tested by the IPI and pass the requirements of the tests and standards. Additional specialist tests are carried out at other leading Institutions, to ensure that the products you see in this catalogue are of the highest quality and safety standards to meet all your conservation needs.



Photographic Activity Test



Acid-free long life papers and boards



100% Cotton Fibre



Fine Art Trade Guild

CXD Scholarship

CXD's commitment and passion to conservation is typified by the creation of the CXD Nicholas Hadgraft Scholarship. Offered in memory of Dr Nicholas Hadgraft, a good friend of Conservation By Design who died tragically in 2004, this annual scholarship provides the recipient with the opportunity to gain new skills and meet like-minded professionals at the Montefiascone Book Conservation Summer School, a unique bookbinding course held each year in the medieval town of Montefiascone, Italy. You can find out more by visiting www.monteproject.com

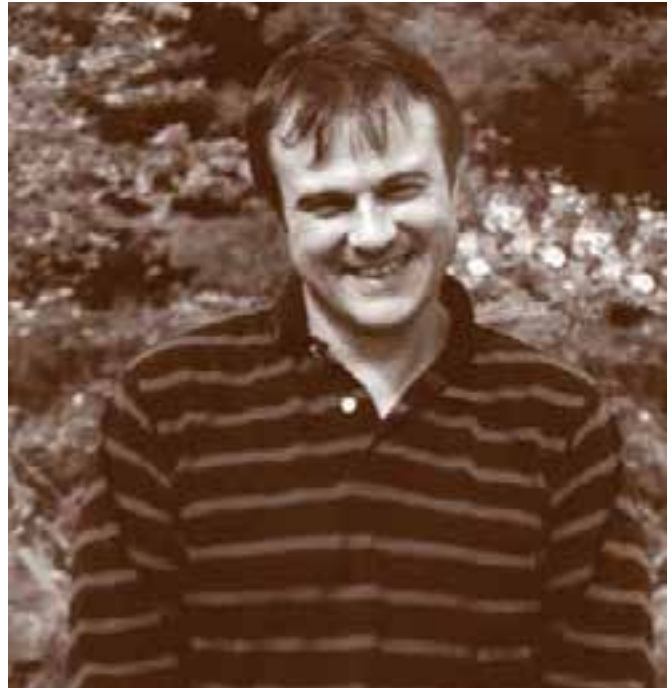

Nicholas Hadgraft

Moulin du Verger Workshop

Since 2007 CXD is also proud to have supported and organised a unique workshop on the principles and practice of handmade papermaking and paper-covered bookbinding. Working with Jacques Brejoux and Christopher Clarkson, two of the industry's leading scholars and craftsmen, this residential workshop is located at the 16th century Moulin du Verger paper mill in Puymoyen, located in the beautiful Charente (Cognac) region of France and delegates have travelled from all over the world to take up this exceptional opportunity.

Contents

Introduction to Conservation By Design Limited	1-3
Contents	4
<hr/>	
Boxes and Storage Products	
Boxes	7-41
Folders	42-66
Transparent Storage	67-79
Oxygen-Free Storage	79-81
<hr/>	
Papers, Materials and Boards	
Papers	84-102
Materials	103-107
Boards	108-120
<hr/>	
Equipment and Accessories	
Conservation Accessories and Tools	123-126
Adhesives Pastes and Consolidants	127-131
Tapes	132-137
Labelling	138-140
Pens, Pencils and Inks	141-142
Book Support and Display	143-146
Hanging Systems and Framing Accessories	147-150
Cutting Equipment	151-161
Repair and Conservation	162-172
Heat-Sealing and Welding Machines	173-174
Box Measuring and Making	175-176
Pest Management	177-178
Oxygen-Free Storage	179-186
Disaster Response Products	187
Humidity Control	188-190
Testing Indicators	190-191
Environmental Monitoring	192-199
Conservation Cleaning	200-212
Protection Equipment and Accessories	213-215
Brushes	216-220
Lighting Equipment	221-229
Cold Storage	230-231
Reference Books and DVDs	231
<hr/>	
Storage and Workshop Furniture	
Planorama®	233-234
Drawer Storage	235-237
Picture and Roll Storage	238
Museum Cabinets	239
Studio Furniture	239-240
<hr/>	
Museum Showcases	
Bespoke Museum Showcases	244
Glass-Top and Display Furniture	245
High-Security Cabinets	246
Display Frames	246
<hr/>	
Glossary of Terms	248
A – Z Index	249-250
Full Product Listing	251-253
Terms and Conditions/How we do business	255
Placing an order	256







Boxes and Storage Products

Boxes

- Boxes and Storage Products
- Box Styles
- Drop-Spine Boxes – Tabbed
- Drop-Spine Boxes
- Cloth-Covered Drop-Spine Portfolio Boxes
- Solander Boxes
- Cloth-Covered Portfolio and Ringbinder Boxes
- Hinged-Lid Boxes
- Hinged-Lid with Carry handle
- Two-Part Boxes
- Drop Wall Boxes
- Window Boxes
- Drawer Tray Boxes
- Storage Trays
- Open-Top Vertical Storage
- Tube Boxes



Folders

- Folders, Envelopes and Pockets Styles
- Single and Double-Crease Folders
- L-Shaped Folders
- Open Topless Wallets/Pockets/Enclosures
- Envelopes/Wallets/Pockets with Flap
- Pocket Envelopes with Non-Adhesive Flap
- Gusseted Expansion Wallets
- Four-Flap Folders
- pHoton™
- Photographic Storage



Transparent Storage

- Polyester Album Pages
- Crystal Polyester Pockets
- Timecare® Crystal Paperbacks
- Timecare® Polyester Rolls and Cut Sheets
- Storage and Transportation Bags



Oxygen-Free Storage

- Oxygen and Moisture-Barrier Bags and Films



Boxes and Storage Products

The Conservation By Design (CXD) box range is one of the largest available and has been built up over many years. It is unique in the variety and quality of materials used to produce them. We provide a design and manufacturing service for die-cut, mass-produced or one-off, computer-generated, made- to-measure Smart Boxes™.

Most of the boxes are manufactured at the CXD Timecare® Works' factory in Bedford with others made by our sister company in France. They have been designed in partnership with clients for the safe long-term storage and preservation of books, documents, newspapers, artworks and photographs. A key figure in the development of the CXD box range is Christopher Clarkson who developed an integrated box, folder and envelope system in 1981 when he was the Conservation Officer at the Bodleian Library in Oxford. Stuart Welch, the founder of CXD, worked with Christopher to develop an improved range of papers and boards from which to produce the Clarkson system. This was the beginning of the CXD Premier Duo™ Archival Folding Boxboard range and Heritage Archival pHotokraft™ papers.

More information on the Clarkson/Bodleian system and its history can be found on our web site.



Duke Parchment box next to vellum bindings

CXD Archival Boxboard Range	Construction
Premier Duo™ Archival Folding Boxboard	Solid Board
Premier Duo™ Archival Fluted Boxboard	Corrugated Centre
Premier Buckram Duo™ Archival Boxboard	Solid Board
PolypHlute™ Fluted Polypropylene	Fluted Centre
EcopHant™ Recycled Archival Boxboard	Solid Board
Superior Millboard™	Solid Board
Bookbinding/Boxmaking Board	

Specifications

All materials used are specified by CXD to the highest archival standard, not only for purity but also for strength. A box has to work mechanically and if the base paper is weak its life will be short, so our aim is to produce boxes which are both permanent and durable. All our boxboard is based on the Heritage Archival pHotokraft™ paper range. The Premier Duo™ Archival Folding Boxboard is laminated with Evacon-R™ adhesive, the Premier Duo™ Archival Fluted Boxboard is corrugated using a starch adhesive. EcopHant™ and Superior Millboard™ are formed using a non-adhesive, multi-layer wet laid process. Full specifications are available in the board section of this catalogue.

Premier Duo™ Archival Folding Solid Centre and Fluted/Corrugated Boxboard

The top of the range Premier Duo™ board is made by laminating or corrugating layers of Heritage Archival pHotokraft™ paper to form boards of varying thickness. The paper is acid and lignin-free and passes the PAT Photographic Activity Test. It contains a high percentage of archival quality, long kraft fibres which give the board excellent fold and tear strength. The paper is sized in the pulp and then surface-sized to give greater water resistance and fold strength. All colours used are highly light-resistant and bleed-proof which protects the contents of the box should it be involved in a flood.

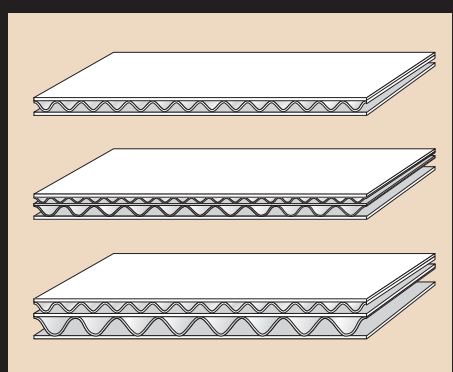

PolypHlute™ Corrugated Polypropylene + Polyethylene



pH neutral, fluted plastic panels made with a copolymer of approximately 90% polypropylene and 10% polyethylene. Lightweight and waterproof, these panels have numerous applications such as making boxes, drawer partitions, shelf coverings, exhibition supports, picture-frame backing etc. PolypHlute™ boards can be cut, grooved, folded, pierced and joined using PolypHlute™ rivets.

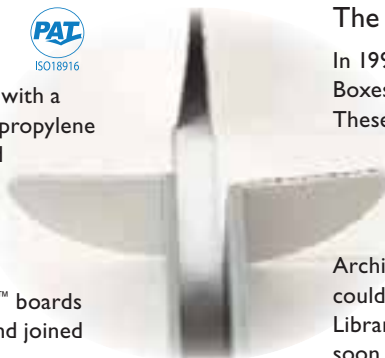

For full specifications see our board section of this catalogue.

EcopHant™ and Superior Millboard™

All the Premier Duo™ boxboard waste from the die-cutting and boxmaking production process in our factory is recycled to produce EcopHant™ and Superior Millboard™. The recycling takes place at a special board mill where all the high-quality paper fibres are re-pulped to a CXD specification using clean water then internally sized and coloured ElepHant Green with bleed-proof dye. This pulp is used to form new EcopHant™ and Superior Millboard™ on an adhesive-free, intermittent cylinder board machine. This process and the quality of the Premier Duo™ archival waste fibre used produces a board of great strength and unusual purity for a recycled board. The EcopHant™ board is made slightly less dense for die-cutting and creasing than the Superior Millboard™ which is made to a higher density preferred for bookbinding and for the manufacture of handmade cloth or leather-covered boxes. Recycling allows CXD to offer very high quality acid and lignin-free boxes at a very competitive price. Both EcopHant™ and Superior Millboard™ have passed the PAT photographic activity test.

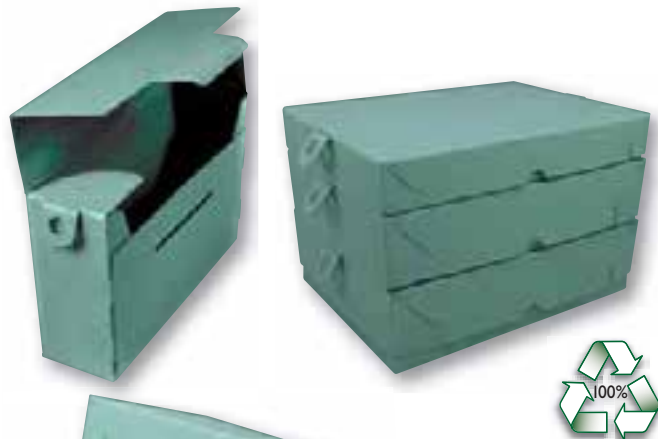

CXD Advertisement

The Lydamore range of boxes

Embossing shown on Premier Duo™ Boxboard and EcopHant™



The CXD Smart Box™ Manufacturing Service

In 1992 CXD were the first European company to supply 'Smart Boxes' individually computer-generated on a boxmaking machine. These boxes were tailor-made to fit a variety of items from the Royal Botanic Gardens, Kew, Parkes Collection of Oriental Paper Objects including umbrellas, hats, books etc. At the same time CXD offered the Kasemake CXD boxmaking machine for sale in conjunction with CXD Premier Duo™ Archival Folding Boxboard to Libraries and Archives so that they could produce their own made-to-measure boxes. The National Library of Scotland being the first to see the potential, they were soon followed by the Bodleian Library, British Library, National Library of Wales and many more in the UK and Internationally. The introduction of the Kasemake CXD system has revolutionised the possibilities and quality of custom-made conservation boxes and fully illustrates the principle of conservation by design.



With this system CXD offer a one-off Smart Box™ manufacturing service using any of the Archival Boxboards and Papers found in this catalogue. All the existing box designs listed in the catalogue are available as Smart Boxes™ and we are happy to work with clients to design new styles that exactly meet a specific need. Names, description of contents or identification marks can be applied to the boxes using the lightfast pigment ink pen on the Kasemake CXD machine. There are a variety of fonts to choose from. Using the special cutting tool we are able to provide customised linings made from Plastazote® foam or Charcoal Cloth™ which uses Activated Charcoal to trap and purify the air within the box.

A Smart Box™ price for every box type and size is listed in our price list with the exception of popular stock sizes that have been produced in volume to achieve one-off boxes at a lower price. Any other size will be quoted on request.



Customised linings

Printing on boxes



Boxes and Storage Products

Die-Cut Boxes, Flat-Packed for Self-Assembly or Ready-Assembled

The majority of the CXD die-cut box designs can be supplied flat for self-assembly which saves on shipping and storage costs for the client, but we are happy to supply any box ready-assembled and hand-finished for customers if required.

FP= Flat-Packed and RA = Ready-Assembled

Box Assembly Methods

According to their design and function boxes can be assembled in many different ways.

They can be assembled using slots, tabs and crash locks. They can be glued, stitched with brass or stainless steel wire, riveted or constructed using the metal-edge system.

Wire-stitched



Metal-edged

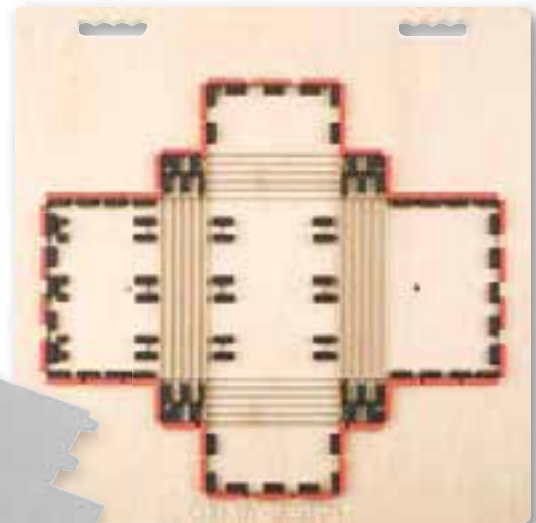

Example of CXD die to make die-cut boxes.

Left: Box supplied flat and ready-assembled with slots and tabs shown.

Handmade Cloth-Covered Boxes

In addition to multiple die-cut or one-off, made-to-measure Smart Boxes™ we offer a variety of handmade cloth-covered boxes fabricated using traditional craft skills. They use durable materials and acid-free paper and board in their construction. They include the Museum and Box Populi ringbinder boxes and the top-of-the-range Solander Boxes which have been a long-time favourite of museums. Special designs, sizes, colours, and finishes can be requested.



Solander Boxes

Opera Portfolio Box

Box Populi Ringbinders

Plastazote® Jumbo Boxes

Sometimes unusual problems need unusual solutions.

Many institutions find themselves with the odd item of extremely large proportions and struggle to find a suitable storage box. Boxes made from foam may not seem like the obvious answer when it comes to producing a large and rigid box that isn't too heavy. CXD had the idea in 1992 that using Plastazote® nitrogen-expanded foam you get an inert material that could be bonded together to form a rigid and very lightweight box. The thickness of the Plastazote® depends on the size of the box but 30mm Plastazote® is often used. Jumbo boxes have been used for storing a variety of museum objects, large textiles and were an ideal solution for storing and transporting theatre models. A choice of colours is available and different colours can be used in the same box. All boxes are custom-made to order.



Sizes and Dimensions

Unless otherwise stated, all sizes/dimensions are expressed as Length x Width (Breadth) x Height.

The longest opening side of the box = Length.

The shortest opening side = Width (Breadth).

The distance from the top of opening to base = Height.

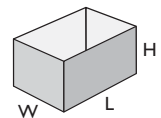

Style Codes: how to use the style code system

In this section the product range has been categorised using 'style codes'. These have been developed to assist customers locate a particular style of Box, Folder, Envelope or Pocket.

These style codes are also of assistance when ordering custom-made Boxes, Folders, Envelopes or Pockets using our 'Smart' computer-generated service.

Just quote the 'style code', provide your desired measurements and quantity to receive a quotation for your approval.



SMART SERVICE
custom-made boxes available
for this product

Box Styles

Style Code

Drop-Spine Boxes (Clamshell)

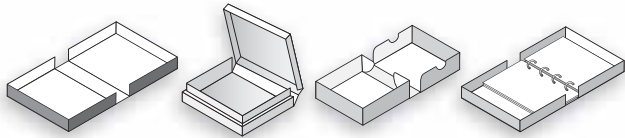

AB – p.11



Hinged-Lid Boxes

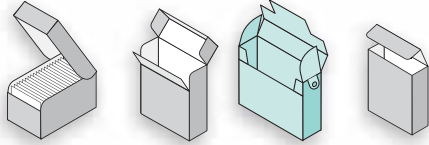

BB – p.22



Hinged-Lid with Carry Handle (Newspaper System)

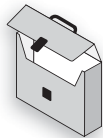

CB – p.27



Two-Part Boxes

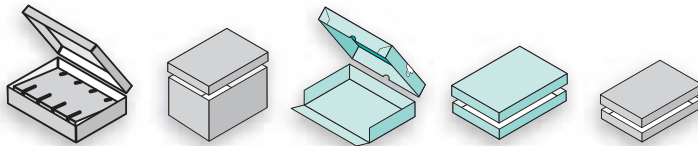

DB – p.28

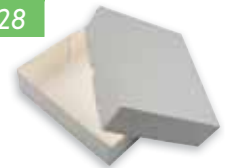

Drop-Wall Box (Exploding Box, Palm Leaf Box)

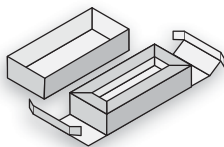

EB – p.36



Window Boxes

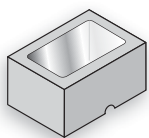

FB – p.37



Drawer-Tray Boxes

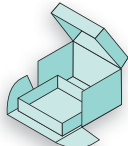

GB – p.38



Storage Trays

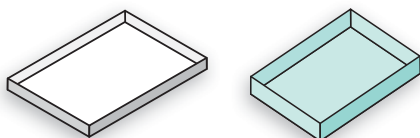

HB – p.39

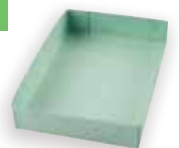

Open-Top Vertical Storage

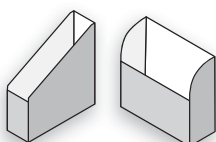

IB – p.39



Roll Storage

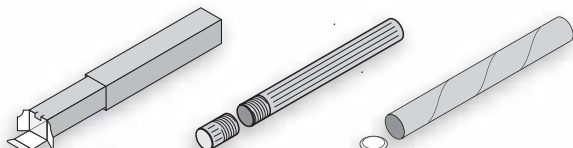

JB – p.40



Drop-Spine Boxes

CXD P-Box Mounting and Storage System

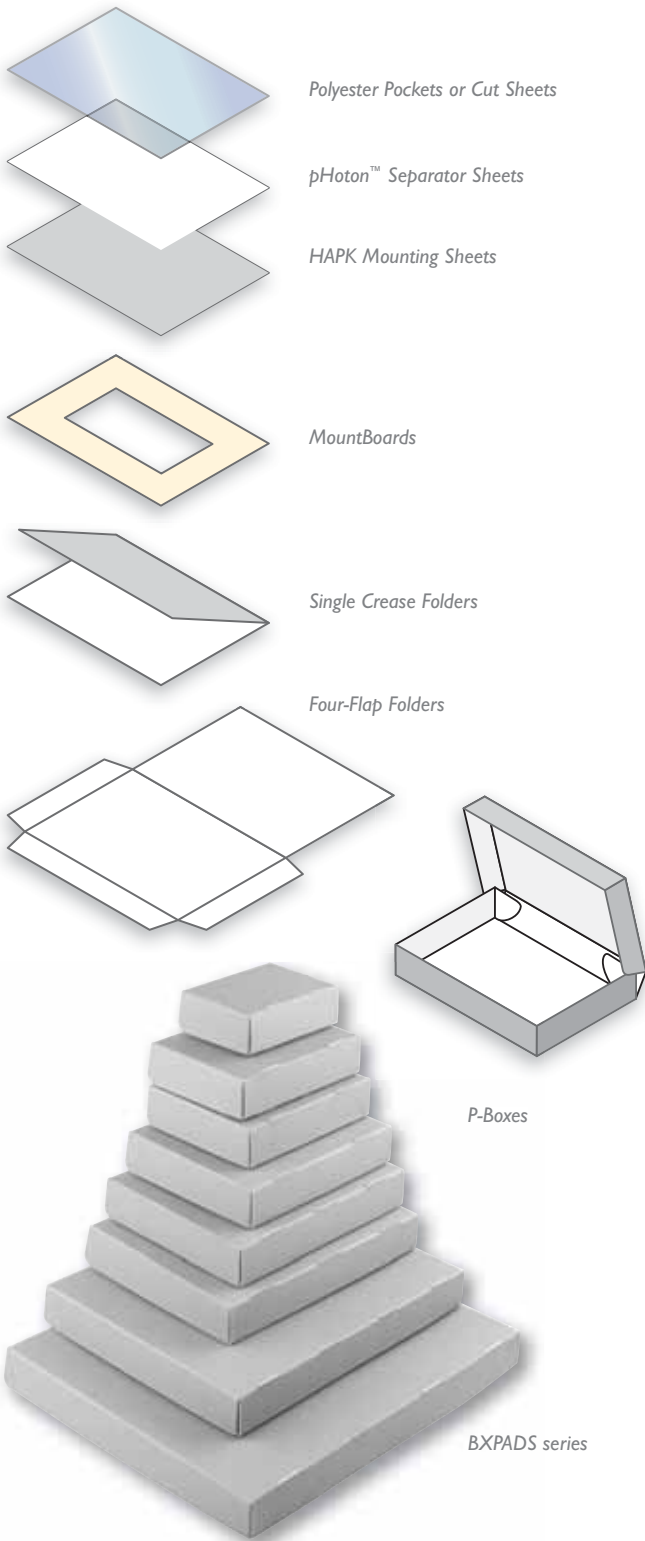

Polyester Pockets or Cut Sheets

pHoton™ Separator Sheets

HAPK Mounting Sheets

MountBoards

Single Crease Folders

Four-Flap Folders

P-Boxes

BXPADS series

Information

P-Box Size Guide

GLASS PLATE SIZES

P0 = 5" x 7"

PZ = 10" x 7"

PHOTOGRAPHIC PRINT SIZES

P1 = 8" x 10"

P2 = 10" x 12"

P3 = 12" x 16"

PX = 14" x 11"

P4 = 16" x 20"

P5 = 20" x 24" or A2

STYLE CODE AB02

Premier Duo™ Drop-Spine Photographic Boxes – Tabbed ('P-Box' System)

Photographic print storage boxes: archival boxboard, tabbed assembly

Developed from the Clarkson design, these boxes are made from photo-safe CXD Premier Duo™ Archival acid-free and lignin-free boxboard, to offer permanence and durability.



Once self-assembled, these boxes are designed to hold mounted photographic prints in most common sizes and are 9.5mm ($\frac{3}{8}$ ") larger than the mount formats.

These form part of the CXD 'P-Box mounting and storage system' including pHoton™ papers, pHoton™ folders, Heritage Archival pHotokraft™ single-crease folders, Polyester pockets and Timecare® Heritage Museum and Conservation mountboards. All available to suit each size of CXD Premier Duo™ P-Boxes.

Parchment and Seal storage folders with Plastazote® inserts are also designed to fit PX and P4 boxes (see page 45).

Specifications

- Made from Premier Duo™ Archival Folding Boxboard
- Acid-free and lignin-free board
- Board Passes Photographic Activity Test (PAT)
- Supplied flat-packed
- Colour: Grey/White as standard



Linked Products: Folders p42; Transparent Polyester p67; pHoton™ p88; Mounting Sheets p12; Mountboard p113; V Mounts p137; Gloves p215; Premier Duo™ Archival Folding Boxboard full specification p110.

P-Box System

Product code	Ref*	Colour	Thickness microns	Internal Size mm	Internal Size inches
BXPADS3754	P0	Grey/White	1300	190 x 143 x 64	7½ x 5½ x 2½
BXPADS3701	PZ	Grey/White	1300	257 x 197 x 64	10¼ x 7¾ x 2½
BXPADS3363	P1	Grey/White	1300	270 x 216 x 64	10⅝ x 8½ x 2½
BXPADS3364	P2	Grey/White	1300	317 x 266 x 64	12½ x 10½ x 2½
BXPADS3368	PX	Grey/White	1300	371 x 293 x 64	14⅝ x 11½ x 2½
BXPADS3365	P3	Grey/White	1300	420 x 319 x 64	16⅞ x 12⅞ x 2½
BXPADS3366	P4	Grey/White	1300	520 x 420 x 64	20½ x 16⅞ x 2½
BXPADS3367	P5	Grey/White	1300	622 x 522 x 64	24½ x 20⅞ x 2½
BXPADS4930	P3 - Shallow	Grey/White	1300	420 x 319 x 45	16⅞ x 12⅞ x 1¾
BXPADS4902	P4 - Shallow	Grey/White	1300	520 x 420 x 40	20½ x 16⅞ x 1⅞

STYLE CODE AB03

Premier Duo™ Drop-Spine Box – Tabless

Drop-spine library and photographic boxes: archival boxboard, tabless assembly

A unique design of box developed by Conservation By Design which eliminates the need for tabs protruding from the exterior of the box which prevents boxes from snagging with other boxes on shelves. These boxes are made from Premier Duo™ Archival acid-free and lignin-free boxboard. The box has a superior look and is a very popular style for bespoke **Kasemake-CXD SMART** boxes. Assembly may require gluing with Evacon-R™ adhesive or a suitable hot-melt adhesive.



SMART SERVICE
custom-made boxes available
for this product

Specifications

- Made from Premier Duo™ Archival Folding Boxboard
- Acid-free and lignin-free board
- Board Passes Photographic Activity Test (PAT)
- Supplied flat-packed
- Colour: Grey/White as standard
- Duke Parchment/White colour available for special order



Linked Products: Folders p42; Envelopes p42; Transparent Polyester Pockets p67; Mounting Sheets p12; Mountboard p113; Premier Duo™ Archival Folding Boxboard full specification p7.

Product code	Colour	microns	Internal Size mm	Internal Size Inches
BXPTDS6226	Grey/White	1300	578 x 432 x 57	22¼ x 17 x 2¼

Special sizes quoted on request.

STYLE CODE AB04

Premier Duo™ Drop-Back Microfilm Boxes

Manufactured from Premier Duo™ Archival acid-free and lignin-free boxboard, this one-piece box has an overlapping lid that folds along the spine. It is self-locking and opens like a book, the spine lays flat to allow easy access to contents.



BXDDBM series

Specifications

- Made from 650 micron Premier Duo™ Archival Folding Boxboard
- Acid-free and lignin-free board
- Board Passes Photographic Activity Test (PAT)
- Supplied flat-packed
- Can be embossed or printed to special order
- Colour: Grey/White as standard
- Duke Parchment/White colour available for special order



Linked Products: Tissue Paper p93, p99-100; Gloves p215; Premier Duo™ pHlip Top Microfilm Boxes p23; Premier Duo™ Archival Folding Boxboard full specification p7.

Product code	Colour	microns	Internal Size mm	Internal Size Inches
BXDDBM3277	Grey/White	650	98 x 98 x 41	3⅞ x 3⅞ x 1⅞
BXDDBM4032	Grey/White	650	98 x 98 x 41	3⅞ x 3⅞ x 1⅞
BXDDBM4201	Grey/White	650	115 x 155 x 25	4½ x 6⅞ x 1

STYLE CODE AB05

Premier Duo™ Library Wire-Stitched, Drop-Spine Box

These one-piece, drop-spine, ready-assembled boxes were designed as an alternative to the flat-packed boxes designed for the Bodleian Library by Christopher Clarkson. Made from Premier Duo™ Archival acid-free and lignin-free boxboard.



SMART SERVICE
custom-made boxes available
for this product

They are secured with brass wire stitches, but only on the front lid so that no wire comes into contact with the contents of the box.

The Library Drop-Spine boxes are ready constructed.

Specifications

- Made from 1300 micron Premier Duo™ Archival Folding Boxboard
- Acid-free and lignin-free board
- Board Passes Photographic Activity Test (PAT)
- Supplied ready-assembled
- Colour: Grey/White as standard
- Duke Parchment/White colour available for special order



Linked Products: Envelopes p42; Folders p42; Tissue Paper p93, p99-100; Gloves p215; Premier Duo™ Drop-Spine Boxes – Tabbed Box p31; Premier Duo™ Archival Folding Boxboard full specification p7.

Product code	Colour	microns	Internal Size mm	Internal Size Inches
BXCAMB6062	Grey/White	1300	184 x 133 x 100	7¼ x 5¼ x 3⅝
BXLDDB3265	Grey/White	1300	197 x 146 x 98	7¾ x 5¾ x 3⅞
BXLDDB3269	Grey/White	1300	229 x 178 x 98	9 x 7 x 3⅞
BXLDDB3270	Grey/White	1300	248 x 197 x 98	9¾ x 7¾ x 3⅞
BXLDDB3271	Grey/White	1300	280 x 229 x 98	11 x 9 x 3⅞
BXLDDB3924	Grey/White	1300	288 x 220 x 94	11⅞ x 8⅞ x 3⅞
BXLDDB3933	Grey/White	1300	365 x 349 x 83	14⅞ x 13¾ x 3¼
BXLDDB0455	Grey/White	1300	292 x 235 x 98	11½ x 9¼ x 3⅞
BXLDDB3267	Grey/White	1300	312 x 235 x 98	12⅞ x 9¼ x 3⅞
BXLDDB3268	Grey/White	1300	343 x 248 x 98	13½ x 9¾ x 3⅞
BXLDDB3025	Grey/White	1300	358 x 300 x 98	14⅞ x 11⅞ x 3⅞
BXLDDB4173	Grey/White	1300	349 x 216 x 89	13¾ x 8½ x 3½
BXLDDB3908	Grey/White	1300	362 x 248 x 86	14¼ x 9¾ x 3⅞
BXLDDB4306	Grey/White	1300	362 x 302 x 98	14¼ x 11⅞ x 3⅞
BXLDDB6755	Grey/White	1300	382 x 294 x 99	15⅞ x 11⅞ x 3⅞
BXLDDB4269	Grey/White	1300	400 x 299 x 85	15¾ x 11¾ x 3⅞
BXNEWS2194*	Grey/White	1300	422 x 359 x 79	16⅞ x 14⅞ x 3⅞
BXNEWS2453*	Grey/White	1300	448 x 394 x 79	17⅞ x 15½ x 3⅞
BXPNEW3205	Grey/White	1300	445 x 395 x 79	17½ x 15⅞ x 3⅞
BXLDDB3830	Grey/White	1300	294 x 226 x 95	11¾ x 8⅞ x 3⅞
BXLDDB5111	Grey/White	1300	382 x 294 x 99	15¾ x 11¾ x 3⅞

*These two boxes are made as two parts stitched together.

Applications

Suitable for archival storage of books, magazines, periodicals, documents, photographs, prints, negatives, transparencies, drawings, letters and ephemera.



Information

Certain styles of boxes are embossed with a box reference number and year of manufacture. Embossing can be specified to all boxes for special order.

STYLE CODE AB16

Premier Duo™ PM Metal-Edge Box

Drop-Spine box for storage of documents and mounted photographs. This box opens flat for easy access to documents.

An economical box offering archival protection for collections.

The boxes are made from 1300 micron Premier Duo™ Grey/White heavyweight boxboard. Metal-edge construction, supplied ready-assembled.

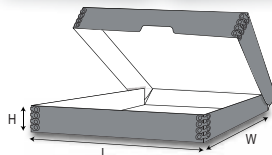

Product code	Internal size mm L x W x H	Internal size inches L x W x H
BXPADM1824	255 x 195 x 60	10 ¹ / ₄ x 7 ³ / ₄ x 2 ³ / ₄
BXPADM2430	310 x 250 x 60	12 ³ / ₄ x 9 ⁷ / ₈ x 2 ³ / ₄
BXPADM2833	335 x 285 x 60	13 ¹ / ₁₆ x 11 ¹ / ₂ x 2 ³ / ₄
BXPADM3040	415 x 315 x 55	16 ¹ / ₂ x 12 ¹ / ₂ x 2 ¹ / ₄
BXPADM4050	515 x 415 x 55	20 ⁷ / ₂ x 16 ¹ / ₂ x 2 ¹ / ₄
BXPADM4154	545 x 415 x 55	21 ² / ₆₄ x 16 ¹ / ₂ x 2 ¹ / ₄
BXPADM4244	440 x 420 x 60	17 ² / ₆₄ x 16 ¹ / ₂ x 2 ³ / ₄
BXPADM5060	615 x 515 x 55	24 ¹ / ₂ x 20 ⁷ / ₂ x 2 ¹ / ₄
BXPADM5374	745 x 535 x 55	29 ² / ₆₄ x 21 ¹ / ₁₆ x 2 ¹ / ₄

STYLE CODE AB24

PolypHlute™ - Documents Box



Fluted polypropylene drop-spine box with double side walls offering a strong, rigid box. Suitable for filing documents away in folders, sleeves, objects or textiles. The boxes are made from PolypHlute™ Corrugated Polypropylene grey board, tabbed construction, supplied flat-packed.

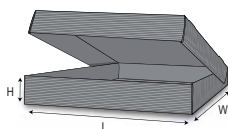

BXPPAD0041 Can hold 4 boxes
BXDOCP0018.

Product code	Internal size mm L x W x H	Internal size inches L x W x H
BXPPAD0021	200 x 150 x 90	7 ⁷ / ₈ x 5 ² / ₂ x 3 ³ / ₄
BXPPAD0031	340 x 250 x 90	13 ² / ₆₄ x 9 ⁷ / ₂ x 3 ³ / ₄
BXPPAD0041	410 x 310 x 90	16 ¹ / ₄ x 12 ³ / ₆₄ x 3 ³ / ₄

STYLE CODE AB25

PolypHlute™ - Periodicals Box



Fluted polypropylene Drop-Spine box. This box is especially designed for the flat storage of newspapers and periodicals.

The boxes are made from PolypHlute™ Corrugated Polypropylene grey board, tabbed construction, supplied flat-packed.

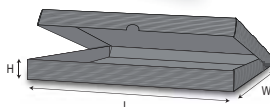

Product code	Internal size mm L x W x H	Internal size inches L x W x H
BXPPAD0082	820 x 620 x 60	32 ² / ₂ x 24 ³ / ₂ x 2 ³ / ₄
BXPPAD0066	660 x 470 x 60	25 ⁶ / ₆₄ x 18 ¹ / ₂ x 2 ³ / ₄
BXPPAD0048	480 x 360 x 50	18 ⁵ / ₆₄ x 14 ¹ / ₆₄ x 1 ³ / ₂

STYLE CODE AB18

Premier Duo™ Partitioned Metal-Edge Boxes for Book Storage

Specially designed to store books of different shapes and sizes in a single box format. The kit includes four 3mm-thick strips – two of 41cm and two of 31cm

– making them adaptable to BXPADM3040 boxes and ideal for storing books ranging from 10 x 13cm to 26 x 36cm.

Made from Premier Duo™ Solid Board. Metal-edge construction, supplied ready-assembled.

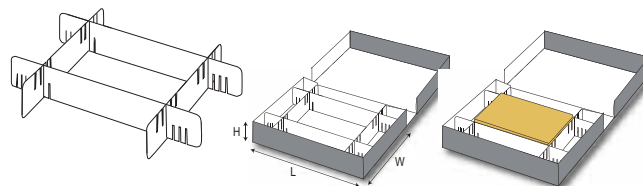

Product code	Description	Size mm	Size inches	Pack qty
BXDIVB3040	Box and dividers	415 x 315 x 55	16 ¹ / ₂ x 12 ¹ / ₂ x 2 ¹ / ₄	1
BXDIVI3040	Dividers set of 4 strips	410 and 310	16 ¹ / ₆₄ and 12 ³ / ₆₄	1

STYLE CODE AB17

Premier Buckram Duo™ - PM Box

Drop-Spine box for storage of documents and mounted photographs. This box opens flat for easy access to documents.

An economical box offering archival protection for collections.

Boxes made from 1300 micron Premier Buckram Duo™ Grey/White heavyweight boxboard covered with Buckram cloth. Metal-edge construction, supplied ready-assembled.

2 colours available - Grey or Black, to be specified when placing order.

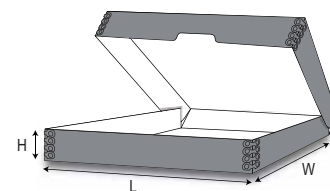

Product code	Internal size mm L x W x H	Internal size inches L x W x H
BXPADB2430	310 x 250 x 60	12 ³ / ₄ x 9 ⁷ / ₈ x 2 ³ / ₄
BXPADB2833	335 x 285 x 60	13 ¹ / ₁₆ x 11 ¹ / ₂ x 2 ³ / ₄
BXPADB3040	415 x 315 x 55	16 ¹ / ₂ x 12 ¹ / ₂ x 2 ¹ / ₄
BXPADB4050	515 x 415 x 55	20 ⁷ / ₂ x 16 ¹ / ₂ x 2 ¹ / ₄



Cloth-Covered Drop-Spine Portfolio Boxes

STYLE CODE AB12

CONCORDE Portfolio Box

Drop-spine/front style: 4 protective side walls

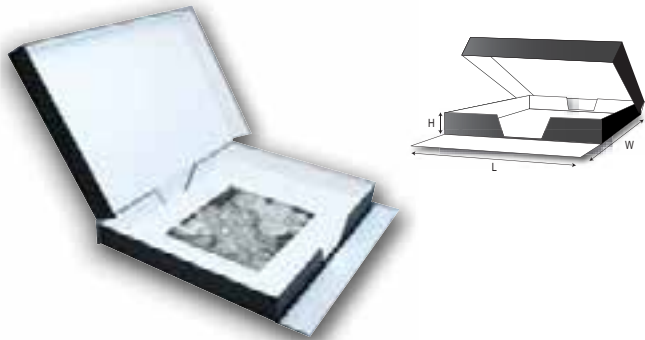

Specifications

- Made of acid-free board, 1600gsm, pH7.5
- Lined on the inside with acid-free paper
- Tyvek® hinges
- Label-holder on the short side
- Formats suitable for mounting standards (40.5 x 53cm and 73 x 52cm)
- Colour: Black Buckram cloth



These drop-spine, drop-front handmade boxes are constructed from acid-free boxboard, lined on the inside with white acid-free paper. The lid is designed to lie flat when open. Covered with black Library Buckram cloth, each box contains a 5mm white Plastazote® sheet which assists removal of the box contents. Aluminium label-holder fitted on front, long side. Often used as high-quality presentation or portfolio boxes.

Product code	Colour	Internal Size mm	Internal Size inches
BXHERA4628	Black	460 x 285 x 65	18 ¹ / ₈ x 11 ¹ / ₄ x 2 ⁵ / ₁₆
BXHERA5441	Black	540 x 415 x 65	21 ¹ / ₄ x 16 ⁵ / ₁₆ x 2 ⁵ / ₁₆
BXHERA7453	Black	740 x 530 x 55	29 ¹ / ₈ x 20 ⁷ / ₈ x 2 ¹ / ₁₆
BXHERA2284	Black	1225 x 842 x 35	48 ¹ / ₄ x 33 ³ / ₈ x 1 ³ / ₁₆

Linked Products: Transparent Polyester Pockets p67; Mounting Sheets p12; pHoton™ p88; V Mount p137; Gloves p215.

STYLE CODE AB13

CARROUSEL Portfolio Box

Drop-spine/front style: 3 protective side walls with strap

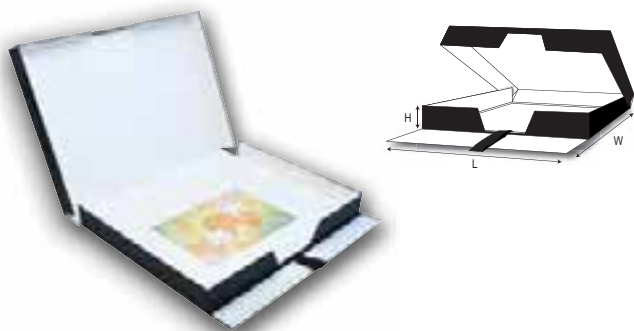

STYLE CODE AB14

OPERA Portfolio Box

Drop-spine: 4 protective side walls



These drop-spine, handmade boxes are constructed from acid-free boxboard, lined on the inside with white acid-free paper. The lid is designed to lie flat when open. Covered with black hydrophobic cloth.

Specifications

- Aluminium label-holder at front, on the long side
- Colour: black water-resistant cloth



Product code	Colour	Internal Size mm	Internal Size inches
BXHERC2632	Black	320 x 260 x 65	12 ⁵ / ₈ x 10 ¹ / ₄ x 2 ⁵ / ₁₆
BXHERC3242	Black	420 x 320 x 65	16 ⁵ / ₁₆ x 12 ⁵ / ₈ x 2 ⁵ / ₁₆
BXHERC4154	Black	540 x 415 x 65	21 ¹ / ₄ x 16 ¹ / ₃₂ x 2 ⁵ / ₁₆
BXHERC4252	Black	520 x 420 x 65	20 ¹ / ₂ x 16 ⁵ / ₁₆ x 2 ⁵ / ₁₆
BXHERC5262	Black	620 x 520 x 65	24 ¹ / ₁₆ x 20 ¹ / ₂ x 2 ⁵ / ₁₆
BXHERC5267	Black	670 x 520 x 50	26 ³ / ₈ x 20 ¹ / ₂ x 1 ⁵ / ₁₆
BXHERC5374	Black	740 x 530 x 55	29 ¹ / ₆₄ x 20 ⁵ / ₆₄ x 2 ¹ / ₁₆
BXHERC6282	Black	820 x 620 x 55	32 ³ / ₁₆ x 24 ¹ / ₁₆ x 2 ¹ / ₁₆

Information

Foolscap folio: its definitions and origins

Foolscap Folio was the traditional paper size used in Europe and the British Commonwealth before the adoption of the international standard A4 paper (the most common standard size in the world) and nominally measures 8.5 inches by 13.5 inches (215.9 x 342.9mm).

Foolscap was named after the fool's cap and bells watermark commonly used from the fifteenth century onwards on paper of these dimensions. In Britain the use of paper with Foolscap watermarks was very rare in the sixteenth and seventeenth century with most examples found in papers imported from either the lower Rhine or from Northern France. By the middle of the eighteenth century the most usual watermarks in Foolscap paper were the Lion of the seven Provinces or the seated Britannia, which by 1800 had become the standard watermark for Foolscap paper.

Product code	Colour	Internal Size mm	Internal Size inches
BXHERB3242	Black	420 x 320 x 65	16 ⁵ / ₁₆ x 12 ⁵ / ₈ x 2 ⁵ / ₁₆
BXHERB4154	Black	540 x 410 x 60	21 ¹ / ₄ x 16 ¹ / ₈ x 2 ³ / ₁₆
BXHERB5374	Black	740 x 530 x 50	29 ¹ / ₈ x 20 ⁷ / ₈ x 1 ⁵ / ₁₆
BXHERB6277	Black	770 x 620 x 50	30 ³ / ₁₆ x 24 ¹ / ₁₆ x 1 ⁵ / ₁₆



Solander Boxes



Daniel Charles Solander
1736–1782

The History of Dr. Solander

Daniel Charles Solander (1736-1782), the botanist, was born in Sweden. He was a pupil of Linnaeus, on whose advice he came to England, where he became Assistant Librarian and afterwards Keeper of Printed Books at the British Museum. He travelled on the Endeavour with Captain Cook on his expedition to the Pacific, his situation in the Museum being kept open for him during his absence.

He was also a Fellow of the Royal Society and acted as Secretary and Librarian to Sir Joseph Banks, the eminent scientist. It is curious that, although unsuccessful attempts were made to commemorate his name, the useful book-form box designed by him, and considered the most satisfactory type of case for prints and manuscripts, is still known as a Solander Box. The good doctor lived 200 years before conservators discovered the need for an acid-free environment and today's Solander Boxes incorporate the very latest available archival materials to protect the contents. In all other respects the design and quality of craftsmanship have been maintained.

STYLE CODE AB15

SOLANDER SUPREME Handmade Boxes

The ultimate storage box

Handmade with plywood frame. Acid-free archival boxboard base, lid and inner shoulders.

Covered in Library Buckram. Lined throughout with acid-free paper. Incorporating polythene barrier between the plywood frame and acid-free shoulder. Card-holder fitted to spine of box. Available in 23 colours of Library Buckram – please specify colour when ordering.

All boxes are handmade to order and we will be pleased to discuss any variations that may be required

Specifications

- Handmade with plywood frame for strength
- Base, lid and shoulder made with acid-free archival boxboard
- Covered in Library Buckram
- Lined throughout with acid-free paper
- Incorporating polythene barrier
- Supplied ready-assembled
- Card-holder fitted
- 23 colours
- Attaché fasteners/hooks can be fitted if required at additional cost

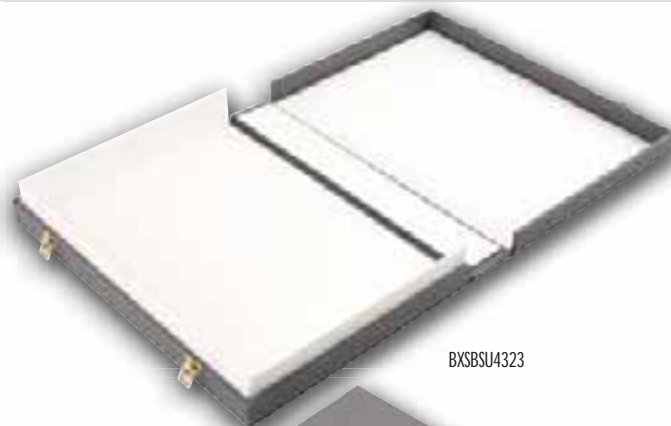

BXSBSU4323

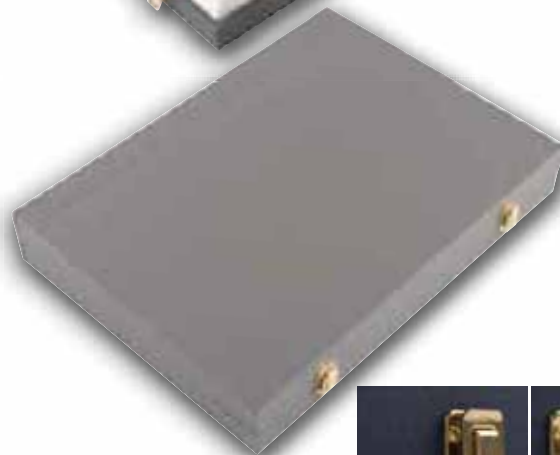

Product code	Type	Internal Size mm	Internal Size inches
BXSBSU4323	A3	432 x 311 x 58	17 x 12¼ x 2⅝
BXSBSU5724	Royal	572 x 419 x 58	22½ x 16½ x 2⅝
BXSBSU6064	A2	606 x 432 x 58	23⅞ x 17 x 2⅝
BXSBSU6995	Imperial	699 x 521 x 58	27½ x 20½ x 2⅝
BXSBSU8266	Atlas	826 x 622 x 58	32½ x 24½ x 2⅝
BXSBSU8546	A1	854 x 606 x 58	33⅞ x 23⅞ x 2⅝

Transparent Polyester Pockets p67; Mounting Sheets p12; pHoton™ p88; V Mount p137; Mount cutters p153; Tapes p132; Gloves p215.

 [Linked Products: Museum and Conservation Mountboard p113;](#)

Library Buckram Cloth Colours

The Library Buckram sample colours shown are a visual guide for initial selection of colour only.

It is important to note that the colours seen will vary according to your computer monitor settings, as well as the settings of your colour printer; should you print off this visual guide. If a precise colour-match is important to you, please request an actual colour swatch sample from Conservation By Design Limited.



For tolerances and advice on ordering Solander Boxes please see page 256.

Cloth-Covered Portfolio and Ringbinder Boxes

STYLE CODE AB11

Timecare® MUSEUM Portfolio Box

Made for long-term storage or high-quality presentation, these top-quality, stylish, handmade portfolio boxes offer protection of sensitive material. A wide range of formats include most common photographic sizes. They can be co-ordinated with the range of CXD pHoton™ papers, envelopes, folders, Timecare® Crystal Paperbacks and Timecare® polyester products.



BXTMPB0513

Shown with Timecare® Crystal Protector (see Transparent Storage section p67).



Handmade and covered with Black Library Buckram

Linked Products: Transparent Storage p67; Polyester Pockets p69; Mounting Sheets p74; pHoton™ p88; V Mount p137; Gloves p215. Photographic 'P-Box' ref, see p12/74.

Product code	Ref	Colour	Internal size mm	Internal size Inches
BXTMPB0786	P1	Black Library Buckram	263 x 212 x 38	10 ³ / ₈ x 8 ³ / ₈ x 1 ¹ / ₂
BXTMPB0994	A4+	Black Library Buckram	311 x 233 x 38	12 ¹ / ₄ x 9 ³ / ₈ x 1 ¹ / ₂
BXTMPB0882		Black Library Buckram	314 x 251 x 51	12 ³ / ₈ x 9 ³ / ₈ x 2
BXTMPB0354	PX	Black Library Buckram	365 x 289 x 51	14 ³ / ₈ x 11 ³ / ₈ x 2
BXTMPB0175	A3	Black Library Buckram	435 x 311 x 32	17 ³ / ₈ x 12 ¹ / ₄ x 1 ¹ / ₄
BXTMPB0984	A3	Black Library Buckram	435 x 311 x 66	17 ³ / ₈ x 12 ¹ / ₄ x 2 ⁵ / ₈
BXTMPB3840	P3	Black Library Buckram	416 x 314 x 32	16 ³ / ₈ x 12 ³ / ₈ x 1 ¹ / ₄
BXTMPB0529	P3	Black Library Buckram	416 x 314 x 63	16 ³ / ₈ x 12 ³ / ₈ x 2 ¹ / ₂
BXTMPB0319	A3+	Black Library Buckram	492 x 342 x 43	19 ³ / ₈ x 13 ¹ / ₈ x 11 ¹ / ₈
BXTMPB4190	P4	Black Library Buckram	517 x 416 x 32	20 ³ / ₈ x 16 ³ / ₈ x 1 ¹ / ₄
BXTMPB0136	P4	Black Library Buckram	517 x 416 x 63	20 ³ / ₈ x 16 ³ / ₈ x 2 ¹ / ₂
BXTMPB0552	A2	Black Library Buckram	612 x 437 x 50	24 ³ / ₈ x 17 ³ / ₈ x 11 ³ / ₈
BXTMPB0513	P5	Black Library Buckram	619 x 517 x 76	24 ³ / ₈ x 20 ³ / ₈ x 3
BXTMPB0914	A1	Black Library Buckram	851 x 604 x 63	33 ¹ / ₂ x 23 ³ / ₄ x 2 ¹ / ₂

Timecare® Portfolio Carrying Cases also available.

Applications

- Suitable for the archival storage of photographic prints, negatives, transparencies, drawings, letters, other valuable artwork, literature or ephemera



STYLE CODE AB10

Timecare® CONNOISSEUR Ringbinder Box

The Connoisseur Ringbinder Box has a sophisticated appearance that will appeal to the specialist collector and will not look out of place in the most traditional library, boardroom or study.



50 page capacity

It is a sturdy handmade box covered in duo-tone Library Buckram with gold blocking, rounded spine and brass corner protectors.

The interior is lined with archival Benchkote™ paper and fitted with a 4-ring '0' mechanism on the spine. This allows the box to lie completely flat when open and it has capacity for 50 Timecare® Album Pages. Other sizes and colours can be made to special order.

Product code	Colour	Internal Size mm	Internal Size inches
BXCONN7468	Blue/Russet (Library Buckram)	335 x 288 x 41	14 x 1 ¹ / ₁₆ x 1 ⁵ / ₈

Ring Configuration

Dimensions and capacity mm



STYLE CODE AB23

pHiClas™ Museum Collection Ringbinder Box



4 D-ringbinder box, 80mm centres, 40mm capacity, with secure locking system and fitted with an aluminium label-holder. The boxes are made from 2500 micron Stouls Satin Conservation – SolidCore board. Lined inside with permanent paper and covered with Black or Grey Buckram cloth, using Evacon-R™ adhesive, hinges made of Tyvek® – a neutral stable material which gives an exceptional tear and fold resistance

Colour: Please specify Black or Grey Buckram cloth.

Product code	Type	Internal size mm L x W x H	Internal size inches L x W x H
BXTCMB3434	A4	340 x 340 x 65	13 ⁵ / ₈ x 13 ⁵ / ₈ x 2 ⁵ / ₈
BXTCMB4339	A3	430 x 385 x 60	16 ⁵ / ₈ x 15 ³ / ₈ x 2 ³ / ₈
BXTCMB4341	A3	430 x 410 x 60	16 ⁵ / ₈ x 16 ³ / ₈ x 2 ³ / ₈

Conservation By Design offer a range of acid-free ring-binder boxes, using a variety of materials and methods of construction, from handmade to machine die-cut which are hand-finished.

To complement all our ringbinder boxes there are a wide range of chemically inert transparent polyester Timecare® album pages with great flexibility of 'pocket' styles which assist in organising the contents. See Transparent Storage section on page 67.

STYLE CODE AB06

Timecare® Library Ringbinder Box

These ringbinder boxes have long been a best seller to both institutional users and the private individual for the storage of a wide range of materials.

The Timecare® Library Ringbinder Box is machine die-cut and hand-assembled from Premier Duo™ Archival acid-free and lignin-free boxboard to offer permanent and durable storage. This fully enclosed box offers the highest quality, but low-cost alternative to the range of cloth-covered ringbinder boxes.

They are recommended by photographic conservators because of the quality of the archival board used, they offer ideal storage for Archives, Libraries and Collectors on a tight budget without sacrificing the highest standards of archival protection.

They have double walls on three sides of the base which give extra rigidity, strength and an extra layer of protection against fire and water. The small internal dust wings help to prevent the ingress of dust and dirt.

A box label is provided and the box is embossed for easy positioning of the label on two sides of the box, depending on the preference of the user as some users prefer the pages hanging vertically from the 'D' ring mechanism.

Since CXD introduced the Library Ringbinder box there have been many imitators, most of which do not have the above features and also have single-wall construction.

Archival mounting paper is available to fit the most popular polyester album pages.

Other sizes and colours can be made to special order.

50-page capacity



 *Linked Products: Transparent Polyester Album Pages p67; Mounting Sheets p12; V Mount p64; Gloves p215; Premier Duo™ Archival Folding Boxboard full specification p7.*



Specifications

- Made from Premier Duo™ 1300 micron Archival Folding Boxboard
- Acid-free, lignin-free, elemental chlorine-free
- Four-post D-ring binder mechanism
- Label-holders provided
- Supplied ready-assembled
- Colour: Grey/White as standard
- Duke Parchment/White on request



Product code	Type	Colour	Thickness microns	Internal Size mm	Internal Size Inches
BXLRBX4015	A4	Grey/White	1300	325 x 310 x 55	12 ³ / ₁₆ x 12 ³ / ₁₆ x 2 ¹ / ₁₆
BXLRBX4099	Foolscape	Grey/White	1300	390 x 330 x 57	15 ³ / ₁₆ x 13 x 2 ¹ / ₁₆
BXLRBX4098	A3	Grey/White	1300	465 x 400 x 57	18 ³ / ₁₆ x 15 ³ / ₁₆ x 2 ¹ / ₁₆
BXLRBX6167		Grey/White	1300	400 x 330 x 40	15 ³ / ₁₆ x 13 x 1 ⁵ / ₁₆
BXLRBX6727	A4	Duke Parchment/White	1300	325 x 310 x 55	12 ³ / ₁₆ x 12 ³ / ₁₆ x 2 ¹ / ₁₆
BXLRBX8545		Grey/White	1300	296 x 439 x 57	11 ² / ₃₂ x 17 ⁷ / ₃₂ x 2 ¹ / ₁₆

Ring Configuration



STYLE CODE AB

Timecare® Certificate Ringbinder Box

The Timecare® Certificate Ringbinder Box and matching Timecare® Crystal Type 2 Polyester 'Certificate' album page has been designed to offer the professional and family archivist with the safest possible environment for the storage and display of historic size certificates. The box protects against light, dust and humidity. The 'Certificate' album page provides crystal clear viewing of documents and protection against damage from handling. Timecare® Type 2 Polyester can be welded with moderate heat using a tacking iron to located and secure items or fragments within the page. Alternatively Heritage Archival pHotokraft™ acid-free paper mounting sheets, transparent V mounts, and mounting corners are available for positioning items of varying size within the page.



Specifications

- Made from 1300 micron Premier Duo™ Archival Folding Boxboard

Applications

Combined system with Timecare® Certificate Page 71 PYTCRP8642 for Birth, Marriage and Death certificates.

 *Linked products: Timecare® Polyester 'Certificate' Album p71; Heritage Archival pHotokraft™ Mounting Inserts p84; Transparent V mounts and mounting corners p137.*

Product code	Description	External Size mm	External Size inches	Pack qty
BXLRBX8625	Library Ringbinder Box	430 x 340 x 57	16 ⁵ / ₁₆ x 13 ³ / ₁₆ x 2 ¹ / ₁₆	1

STYLE CODE AB07

Timecare® Library CDI20 Ringbinder Box System

Proactive protection system for the storage of digital media.

The CDI20 ringbinder storage system for CD/DVDs features Corrosion Intercept® technology CD album pages which attract and neutralise corrosive gases extending the life of your digital media. The CDI20 offers you 15 Corrosion Intercept® double-sided pages presented in a Timecare® Premier Duo™ archival acid-free and lignin-free ringbinder box.



BXLRBX6233

Ring Configuration

Dimensions and capacity mm

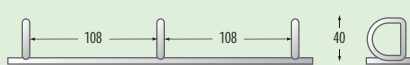

Specifications

- Made from Premier Duo™ Archival Folding Boxboard
- Board is acid-free and lignin-free
- Three-post D-ring binder mechanism
- Each Corrosion Intercept® page holds 8 CD/DVDs
- High-density storage with 120-disc capacity
- Colour of box: Grey/White

LONG LIFE



Applications

- Protective storage for digital media discs

Linked Products: other Corrosion Intercept® Products p106; other CD Storage Products p19-20; Premier Duo™ Archival Folding Boxboard full specification p110, Gloves p215.

Product code	Colour	microns	Internal Size mm	Internal Size Inches	RA/FP
BXLRBX6233	Grey/White	1300	290 x 324 x 55	11 ¹ / ₁₆ x 12 ³ / ₄ x 2 ¹ / ₁₆	RA

Information

Corrosion Intercept Technology™

State of the Art in Corrosion Protection

Developed by Lucent Technologies Bell Labs
Distributed by Conservation by Design Limited



... simply better protection!

CORROSION INTERCEPT® is a revolutionary, patented technology which uses semi-conductor technology to transform plastic into a protective reactive barrier against corrosive gases, fungus and bacteria. It is comprised of highly reactive copper particles bonded into a polymer matrix. This matrix film forms a preferential corrosion site that reacts and neutralises all corrosive gases that pass through or come in contact with the film. It is statistically improbable that they can migrate through the INTERCEPT film without contacting and reacting with one of the active corrosion sites. CORROSION INTERCEPT® provides a unique and effective protection for copper, silver, brass, bronze, ferrous and non ferrous metals. It has also been successfully used to protect CD's, photographic prints, film, textiles, paintings, books and other works of art on paper. This inert material does not give off any harmful gases and is unaffected by moisture, humidity or temperature and it has a built in saturation indicator. When the copper colour turns it is time to change the Intercept. The protection against corrosion is approximately 10 years per 0.025mm thickness of INTERCEPT.

www.intercept-technology.com

Corrosion Intercept Technology™ CD Jewel Case

SUCICD0002

Single jewel case consisting of a moulded Corrosion Intercept® insert tray to store the disk and a clear polystyrene outer. Insert tray has central push mechanism for easy disk release.



Linked Products: CD Storage Boxes p17; CD Cases p19; Corrosion Intercept® Films and Bags p106; CXD Ringbinder Boxes p17-18.

Product code	Description	Size mm	Pack qty
SUCICD0002	Complete unit	124 x 142 x 15	5
SUCICD0003	Insert only	117 x 140 x 10	5

Also Timecare® Ringbinder Box for storage in Corrosion Intercept® album pages see Boxes section p18.

Other CD Storage Cases (not Corrosion Intercept®)

Product code	Description	Size mm	Size inches	Pack qty
SUCICD0004	Clear Jewel (base and lid)	124 x 142 x 10	4 ⁷ / ₁₆ x 5 ⁵ / ₁₆ x ³ / ₁₆	5
SUSPCD0056	Shatter-proof Visi Clear	124 x 142 x 10	4 ⁷ / ₁₆ x 5 ⁵ / ₁₆ x ³ / ₁₆	1

Damage is caused to disks when ozone and reactive oxygen causes the aluminium layer on the CD/DVDs to breakdown.

When aluminium in a thin film oxidises, it becomes clear and unable to reflect the laser pulse attempting to read the CD/DVD. CDI20 album pages protect against this failure.



Aluminium layer subject to oxidation from ozone and reactive oxygen. Damaged disk will be unable to play

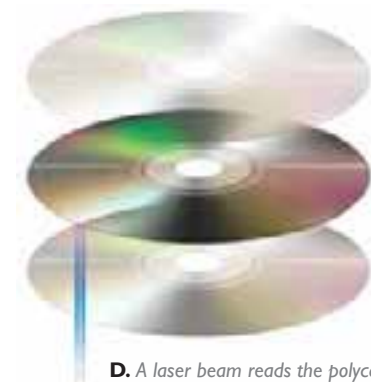

A. A lacquer layer is used to help prevent oxidation.

B. A reflective layer reflects the laser back.

C. A polycarbonate disk layer has the data encoded by using bumps.

D. A laser beam reads the polycarbonate disk, is reflected back and read by the player.

Timecare® Box Populi Ringbinder

New and improved archival quality. These handmade boxes are fully enclosed and constructed from CXD acid-free Superior Millboard™ lined on the inside with CXD white Heritage Archival pHotokraft™ paper. The outer box is covered with strengthened black paper and the spine covered with Library Buckram cloth.

They come with a label-holder and are fitted with a four-post 40mm capacity D-ringbinder mechanism. Now available with a choice of coloured spines to help distinguish contents. Other sizes and colours can be made to special order.

50-page capacity



Mounting Sheets p12; pHoton™ p88; V Mounts p137; Gloves p215.

Product code	To fit	Colour outer/spine	Internal size mm	Internal size Inches
BXTCBP0585	A4	Black/Black	330 x 311 x 57	13 x 12¼ x 2¼
BXTCBP0531	A4	Black/Green	330 x 311 x 57	13 x 12¼ x 2¼
BXTCBP0569	A4	Black/Ochre	330 x 311 x 57	13 x 12¼ x 2¼
BXTCBP0551	A4	Black/Purple	330 x 311 x 57	13 x 12¼ x 2¼
BXTCBP0548	A4	Black/Blue	330 x 311 x 57	13 x 12¼ x 2¼
BXTCBP0535	A4	Black/Red	330 x 311 x 57	13 x 12¼ x 2¼
BXTCBP7380	Foolscap	Black	390 x 330 x 57	13 x 12¼ x 2¼

Linked Products: Transparent Polyester Album Pages p67;

Ring Configuration for Populi and Museum

A4
Dimensions and capacity mm

Three-post D-ring mechanism to special order

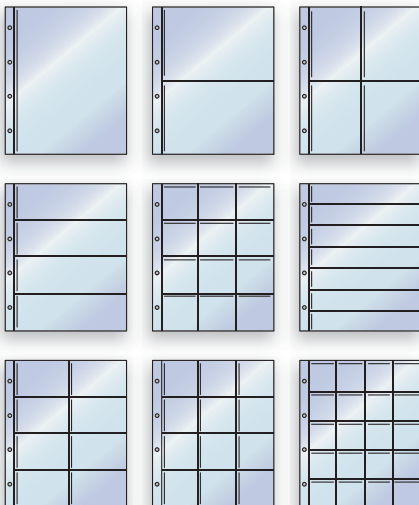

Timecare® Polyester Album Pages:
A selection of the A4 pages available

Timecare® Museum Ringbinder Box

The Museum box has been protecting archival materials since the early 1980s. These hard-wearing, stylish, handmade boxes offer maximum protection for the storage of especially sensitive material, such as photographic negatives, where the safest possible microclimate is called for. Constructed from acid-free PAT tested Premier Duo™ Archival Board. The box is covered in hard-wearing, high-quality, Black Library Buckram that is moisture and vermin-resistant.

Other sizes and colours can be made to special order.

Specifications

- Made from Premier Duo™ Archival boxboard
- Covered in high-quality Black Library Buckram
- Board contains less than 5 parts per million reducible sulphur
- Board passes the ANSI pH1.35 Photographic Activity Test
- Fitted with four-post D-ring binder mechanism
- Colour: Black
- For full board specification see p7



Applications

- Suitable for use for long-term archival storage of photographs, prints, negatives, transparencies, drawings and other valuable art work

Linked Products: Transparent Polyester Album Pages p67; Mounting Sheets p12; V Mounts p137; Gloves p215.

Product code	To fit	Colour	Internal Size mm	Internal Size Inches
BXTCMB0001	A4	Black Library Buckram	330 x 311 x 57	13 x 12¼ x 2¼



50-Timecare® Album Page capacity

STYLE CODE AB19

Premier Duo™ Metal-Edge Ringbinder Box



4 D-ringbinder box, 80mm centres, 40mm capacity, with secure locking system. Metal-edge construction, supplied ready-assembled. Manufactured using 1300 micron Premier Duo™ Grey/White boxboard. An economical box for storing documents in Polyester Album Pages.

Product code	Type	Internal size mm L x W x H	Internal size inches L x W x H
BXCLAS2833	A4	340 x 310 x 60	13 ²⁵ / ₆₄ x 12 ¹³ / ₆₄ x 2 ²³ / ₆₄
BXCLAS4244	Prestige	420 x 450 x 60	16 ¹⁷ / ₃₂ x 17 ²³ / ₃₂ x 2 ²³ / ₆₄
BXCLAS0003	A3	440 x 420 x 60	17 ²³ / ₆₄ x 16 ¹⁷ / ₃₂ x 2 ²³ / ₆₄
BXCLAS0002	A2	630 x 520 x 60	24 ⁵¹ / ₆₄ x 20 ¹⁵ / ₃₂ x 2 ²³ / ₆₄

STYLE CODE AB20

Premier Duo™ ECL Ringbinder Album + Slipcase

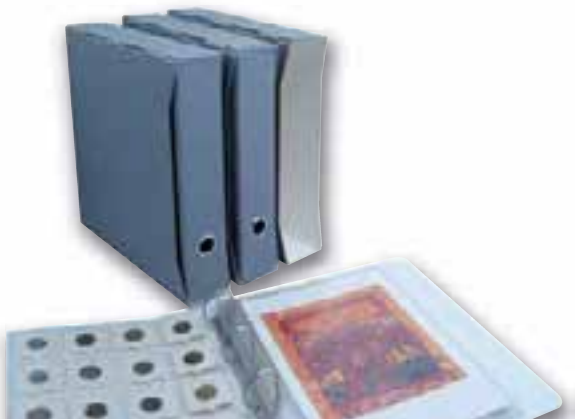

Open ringbinder with slipcase, both made from 1600 micron Premier Duo™ Grey/White Boxboard. 4 D-ring mechanism with security system. Rounded corners plus hole on spine used for handling. Overall dimensions (ringbinder in its case): 33.5 x 35 (h) x 7cm.

An alternative to the Ringbinder Boxes model for people who prefer to use traditional ringbinder files.

Product code	Internal size mm L x W x H	Internal size inches L x W x H
BXCLAS2130	70 x 330 x 340	2 ⁷ / ₄ x 12 ²⁹ / ₆₄ x 13 ²⁵ / ₆₄

STYLE CODE AB21

pHiClas™ Museum Collection Ringbinder Album + Slipcase



Open Ringbinder with slipcase, lined inside with permanent paper and covered with Black or Grey Buckram cloth using a neutral adhesive. Hinges made of Tyvek®, a neutral stable material which gives exceptional tear and fold resistance. 4 D-ringbinder box, 80mm centres, 40mm capacity, secure locking system. Fitted with an aluminium label-holder.

The slipcase is shaped for easy removal of the binder.

Colour: Please specify Black or Grey Buckram cloth.

Product code	Internal size mm L x W x H	Internal size inches L x W x H
BXBCPH6529	65 x 295 x 340	2 ⁷ / ₁₆ x 11 ³⁹ / ₆₄ x 13 ²⁵ / ₆₄
BXBCPH8029	80 x 295 x 340	3 ³ / ₃₂ x 11 ³⁹ / ₆₄ x 13 ²⁵ / ₆₄

STYLE CODE AB22

pHiClas™ Museum Collection Ringbinder Box



4 D-ringbinder box, 80mm centres, 40mm capacity, with secure locking system. Fitted with an aluminium label-holder. The base of the box includes an additional hinged drop-front flap which opens up making it easier to handle the documents.

The boxes are made from 2500 micron Stouls Satin Conservation SolidCore board. Lined inside with permanent paper and covered with Black or Grey Buckram cloth, using Evacon-R™ adhesive, hinges made of Tyvek®, a neutral stable material which gives exceptional tear and fold resistance.

Colour: Please specify Black or Grey Buckram cloth.

Product code	Internal size mm L x W x H	Internal size inches L x W x H
BXTCMB3428	340 x 290 x 60	13 ²⁵ / ₆₄ x 11 ²⁷ / ₆₄ x 2 ²⁵ / ₆₄
BXTCMB4243	420 x 440 x 60	16 ¹⁷ / ₃₂ x 17 ²³ / ₆₄ x 2 ²⁵ / ₆₄

Hinged-Lid Boxes

STYLE CODE BB01

Premier Duo™ Hinged-Lid Glass Plate Negative, Microfiche, Postcard and CD Storage Box

This multi-purpose hinged-lid box has a unique design that helps give rigidity and strength, including a double thickness inner wall at the front. These boxes are made from Premier Duo™ Archival acid-free and lignin-free Boxboard. The box has a fully hinged lid to allow easy access to contents. The sturdy box style is ideal for storing heavy items. The boxes are supplied flat-packed for easy, low-cost shipping and space-saving. Secured using tabs and slots for assembly without the need for wire-stitching or gluing.

They can be supplied with Plastazote® CXD Channel Panels, extra internal boxboard liners or activated carbon Charcoal Cloth™ for extra protection.

Specifications

- Made from Premier Duo™ Archival Folding Boxboard
- Supplied flat-packed
- Colour: Grey/White as standard
- Duke Parchment/White colour available for special order



Glass plate negative boxes: example shown of option with Plastazote® CXD Channel Panels to hold negatives vertically within a pHoton™ four-flap folder.

Applications

- Suitable for archival storage of glass plate negatives as well as microfiche, negatives, photographs and postcards

Linked Products: pHoton™ p88; 4- Flap Folders p55/56; Channel Panel p120; Transparent Polyester Pockets p67; Plastazote® p120; Gloves p215; Premier Duo™ Archival Folding Boxboard full specification p7.

Product code	Description	Colour	Thickness microns	Internal size mm	Internal size Inches	RA /FP
BXPHLM4027	Stereo Negative	Grey/White	650	115 x 62 x 50	4½ x 2½ x 2½	FP
BXPHLM6646	Stereo Negative	Duke Parchment/White	650	115 x 62 x 50	4½ x 2½ x 2½	FP
BXPHLM4536		Grey/White	1300	120 x 300 x 55	4¾ x 11¾ x 2½	FP
BXPHLM3229	Quarter Glass Plate*	Grey/White	1300	128 x 150 x 106	5½ x 5¾ x 4¾	FP
BXPHLM3730	5"x4" Glass Plate Negatives*	Grey/White	1300	130 x 300 x 110	5½ x 11¾ x 4¾	FP
BXPHLM4329	5"x4" Glass Plate Negatives	Grey/White	1300	132 x 164 x 118	5½ x 6½ x 4¾	FP
BXPHLM6175		Grey/White	1300	135 x 300 x 180	5½ x 11¾ x 7½	FP
BXPHLM3919	35x70mm Glass Plate Negatives	Grey/White	1300	140 x 300 x 75	5½ x 11¾ x 2½	FP
BXPHLM6647	35x70mm Glass Plate Negatives	Duke Parchment/White	1300	140 x 300 x 75	5½ x 11¾ x 2½	FP
BXPHLM6609		Grey/White	1300	150 x 164 x 125	5¾ x 6½ x 4¾	FP
BXPHLM3753	Postcard/Microfiche	Grey/White	1300	156 x 130 x 108	6¼ x 5¼ x 4¼	FP
BXPHLM6166		Grey/White	1300	158 x 143 x 128	6¼ x 5¾ x 5½	FP
BXPHLM3846	5"x6" Glass Plate Negatives	Grey/White	1300	160 x 190 x 145	6¼ x 7½ x 5½	FP
BXPHLM6094		Grey/White	1300	170 x 150 x 130	6½ x 5¾ x 5½	FP
BXPHLM3230	Half Glass Plate*	Grey/White	1300	190 x 150 x 144	7½ x 5¾ x 5½	FP
BXPHLM6648	Half Glass Plate*	Duke Parchment/White	1300	190 x 150 x 144	7½ x 5¾ x 5½	FP
BXPHLM3945	5"x7" Prints	Grey/White	1300	190 x 150 x 150	7½ x 5¾ x 5¾	FP
BXPHLM4535	5"x7" Prints	Grey/White	1300	192 x 300 x 140	7½ x 11¾ x 5½	FP
BXPHLM6333		Grey/White	1300	215 x 120 x 166	8½ x 4¾ x 6½	FP
BXPHLM4420	Full Glass Plate	Grey/White	1300	225 x 217 x 179	8¾ x 8¾ x 7½	FP
BXPHLM3231	Full Glass Plate*	Grey/White	1300	229 x 150 x 188	9 x 5¾ x 7½	FP
BXPHLM3917	Full Glass Plate	Grey/White	1300	230 x 130 x 170	9¼ x 5¼ x 6½	FP
BXPHLM4441		Grey/White	1300	250 x 165 x 150	9¾ x 6½ x 5¾	FP
BXPHLM6128		Grey/White	1300	270 x 95 x 200	10¾ x 3¾ x 7½	FP
BXPHLM6603		Grey/White	1300	275 x 150 x 226	10¾ x 5¾ x 8¾	FP
BXPHLM6129		Grey/White	1300	310 x 100 x 230	12¾ x 3¾ x 9¼	FP
BXPHLM6130		Grey/White	1300	350 x 100 x 260	17¼ x 13 x 5½	FP
BXPHLM5109		Grey/White	1300	86 x 155 x 86	3¾ x 6¼ x 3¾	FP
BXPHLM4726	With concertina divider	Grey/White	1300	212 x 360 x 160	8¾ x 14¾ x 6½	FP
BXPHLM4533	Upright for 3.5"x4" prints	Grey/White	1300	110 x 300 x 95	4¾ x 11¾ x 3¾	FP
BXPHLM4682	Upright 'D' ring pull. CD Storage	Grey/White	1300	140 x 320 x 160	5½ x 12¾ x 6¾	RA
BXPHLM6165	Upright	Grey/White	1300	246 x 143 x 195	9¾ x 5¾ x 7½	FP
BXPHLM8540		Grey/White	1300	196 x 300 x 144	7¾ x 11¾ x 5¾	FP
BXPHLM8541		Grey/White	1300	178 x 300 x 131	7¼ x 11¾ x 5¾	FP
BXPHLM8542		Grey/White	1300	118 x 300 x 102	4¾ x 11¾ x 4¾	FP

*With liner.

STYLE CODE BB02

Premier Duo™ Upright Document Boxes

Made from Premier Duo™ Archival acid-free and lignin-free boxboard. A one-piece upright box with hinged lid to allow easy access to contents.

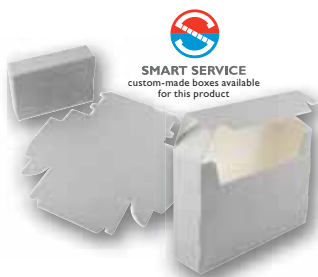

SMART SERVICE
custom-made boxes available
for this product

Specifications

- Made from Premier Duo™ Archival Folding Boxboard
- Supplied flat-packed
- Colour: Grey/White as standard
- Duke Parchment/White colour available for special order



Applications

- Suitable for archival storage of documents, photographs, prints, negatives, transparencies, drawings and ephemera

Product code	Colour	Thickness microns	Internal Size mm	Internal Size inches
BXDOCC3965	Grey/White	1300	377 x 100 x 265	14 ⁹ / ₁₆ x 3 ¹⁵ / ₁₆ x 10 ¹ / ₁₆

Linked Products: Envelopes p42; Folders p54-60; Tissue Paper p93, p99-100; Gloves p215.

STYLE CODE BB05

Premier Duo™ Upright Hinged-Lid Box



SMART SERVICE
custom-made boxes available
for this product

BXPFLM3880

BXPFLM3232

Made from Premier Duo™ Archival acid-free and lignin-free boxboard; this box has a fully hinged lid on the long side. It is die-cut, brass wire-stitched with an inner liner to cover the stitches and has a crash-lock base that allows it to be flat-packed for easy low-cost shipping and space-saving.

Originally designed for pHoton™ paper enclosures for 12" x 10" glass plate storage, this style is now available in other sizes to provide storage solutions for a variety of artefacts.

Specifications

- Made from Premier Duo™ Archival Folding Boxboard
- Supplied flat-packed
- Colour: Grey/White as standard
- Duke Parchment/White colour available for special order



Applications

- Suitable for archival storage of documents, photographs, phonographic records. eg. LP records, CDs, prints, large glass negatives and ephemera

Product code	Type	Colour	Thickness microns	Internal Size mm	Internal Size inches
BXPFLM3232	10" x 8" glass plate negatives	Grey/White	1300	267 x 150 x 226	10 ¹ / ₂ x 5 ⁷ / ₈ x 8 ⁷ / ₈
BXPFLM3880	12" x 10" glass plate negatives	Grey/White	1300	311 x 64 x 260	12 ¹ / ₄ x 2 ¹ / ₂ x 10 ¹ / ₄
BXPFLM4683	LP Storage – with D-ring pull	Grey/White	1300	330 x 120 x 330	13 x 4 ³ / ₄ x 13
BXPFLM5123	LP Storage	Grey/White	1300	381 x 64 x 305	15 x 2 ¹ / ₂ x 12

Linked Products: pHoton™ 4-flap folders/folders p52; Envelopes/folders p43; Tissue Paper p93, p99-100; Premier Duo™ Archival Folding Boxboard full specification p7.

STYLE CODE BB03

Lydamore Upright Document Box

The Lydamore document box is a strong, flat-packed, die-cut box made from EcopHant™ recycled boxboard. This upright box has a fully hinging lid on the long side to allow easy access to contents and two durable tabs for easy handling and carrying.



SMART SERVICE
custom-made boxes available
for this product

Durable
pull-tabs

Great care has gone into the design of this box to minimise ingress of water from a burst pipe/flood by the addition of 'water wings' to the top of the box. The specification of the EcopHant™ material is also water-resistant and bleed-proof. The boxes are supplied flat-packed with all the fittings for easy, low-cost shipping and space-saving. Self-assemble when ready to use. Certain styles of boxes are embossed with a box reference number and year of manufacture. Embossing can be specified to all boxes for special order.

Specifications

- Made from CXD EcopHant™ recycled acid-free boxboard
- Supplied flat-packed
- Durable pull tab and water wings
- Colour: Bleed-Proof Elephant Green



Applications

- Suitable for archival storage of documents, photographs, prints, negatives, transparencies, drawings and ephemera

Product code	Type	Colour	Thickness microns	Internal Size mm	Internal Size inches
BXDOCC6746	Folio	Elephant Green	1300	372 x 107 x 277	14 ¹ / ₂ x 4 ¹ / ₁₆ x 10 ¹ / ₁₆

For assembly instructions and more information on the wider range of Lydamore boxes see p8/23/29.

Linked Products: Envelopes p42 and 51; Folders p42; Tissue Paper p93, p99-100; Gloves p215.

STYLE CODE BB04

Premier Duo™ pHlip™ Top Microfilm Boxes

Made using Premier Duo™ Archival acid-free and lignin-free boxboard, this upright one-piece die-cut box has a fully hinged lid on the one side to allow easy access to contents offering both practical and safe storage.

Suitable for archival storage of microfilm.



Specifications

- Made from Premier Duo™ Archival Folding Boxboard
- Acid-free, lignin-free, OBA-free
- Supplied flat-packed
- Colour: Grey/White as standard
- Duke Parchment/White colour available for special order



Product code	Colour	Thickness microns	Film	Internal Size mm	Internal Size inches
BXPTMB3668	Grey/White	650	16mm	152 x 152 x 25	6 x 6 x 1
BXPTMB3669	Grey/White	650	16mm	76 x 76 x 25	3 x 3 x 1
BXPTMB6082	Grey/White	650	16mm	98 x 98 x 25	3 ⁷ / ₈ x 3 ⁷ / ₈ x 1
BXPTMB4359	Grey/White	650	35mm	98 x 98 x 41	3 ⁷ / ₈ x 3 ⁷ / ₈ x 1 ¹ / ₂
BXPTMB1973	White/White	610	35mm	98 x 98 x 41	3 ⁷ / ₈ x 3 ⁷ / ₈ x 1 ¹ / ₂

Linked Products: Gloves p215; Premier Duo™ Drop Back Microfilm Boxes p13.

STYLE CODE BB06

NOTARY Box



BXHERD3040

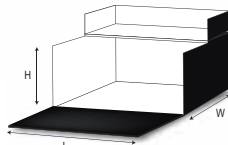

Upright hinged lid, drop-front

A stylish handmade box for the storage and preservation of documents in files or folders.

This special design allows good accessibility: the lid hinges backwards while the front drops open completely. Handle and label-holder. Black Buckram cloth covering.

Specifications

- Made of 1800gsm acid-free board
- Lined with 120gsm Heritage Archival pHotokraft™ acid-free paper
- Front of box has handle and label-holder
- Colour: Black Buckram cloth

Product code	Colour	Internal size mm L x W x H	Internal size inches L x W x H	RA /FP
BXHERD3040	Black	400 x 300 x 200	15¼ x 11¾ x 7¾	RA

Linked Products: Folders p42.

STYLE CODE BB07

Premier Duo™ PV Metal-Edge Box



Upright hinged-lid box with a large opening for easy handling of documents. Box designed for archiving documents and photographic glass plates. Depending on format, Premier Duo™ PV Metal-Edge stores 15 to 80 plates protected individually in Heritage Archival pHotokraft™ pockets. The documents can be held using Plastazote® (see p120). Boxes made from 1300 micron Premier Duo™ Grey/White heavyweight boxboard. Metal-edge construction, supplied ready-assembled.

Product code	Internal size mm L x W x H	Internal size inches L x W x H
BXPPLS1318	210 x 100 x 155	8¼ x 3½ x 6¼
BXPPLS1824	270 x 70 x 200	10½ x 2¾ x 7¾
BXPPLS2430	330 x 60 x 265	12¾ x 2¾ x 10½
BXPPLS0069	230 x 120 x 90	9¼ x 4¾ x 3¾
BXPPLS0912	150 x 120 x 110	5¾ x 4¾ x 4¾

STYLE CODE BB08

Premier Duo™ NG Metal-Edge Box



Hinged-lid microfiche and glass plate negative box for archiving 35mm negatives in 6-frame strips and 120mm in 3-frame strips and 4x5" negatives.

A complete system for archiving and indexing negatives in excellent conservation conditions. Metal-edge construction, supplied ready-assembled.

Boxes made from 1000 micron Premier Duo™ Grey/White boxboard.

Optional: set of 6 dividers : BXPPLN3512

Product code	Internal size mm L x W x H	Internal size inches L x W x H	Linked pocket
BXPPLS0045	140 x 125 x 125	5¾ x 4¾ x 4¾	FDPPLS0045
BXPPLS3512	275 x 140 x 110	10¾ x 5¾ x 4¾	FDPPLS3512
BXPPLN3512	270 x 105	10¾ x 4¾ x 4¾	

Negative Pockets for BXPPLS0045 – Access on the two adjacent sides

Product code	Colour	Weight gsm	Internal size mm L x W x H	Internal size inches L x W x H
FDPPLS0045	White	120	90 x 260	3¾ x 10¾

Negative Pockets for BXPPLS3512 – Access on the short side

Product code	Colour	Weight gsm	Internal size mm L x W x H	Internal size inches L x W x H
FDPPLS3512	White	120	102 x 127	4¾ x 5

STYLE CODE BB09

Premier Duo™ Metal-Edge Fiche Box

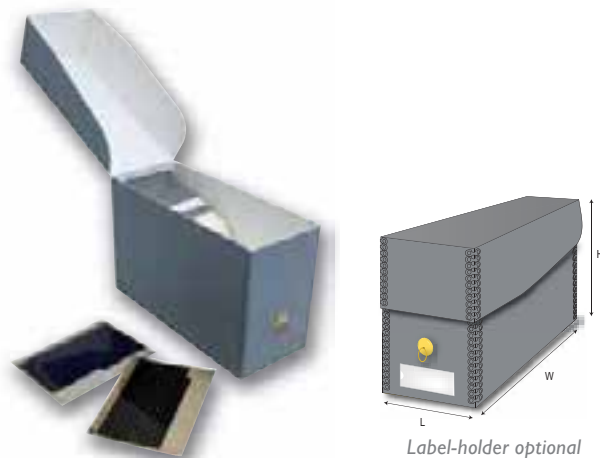

This hinged-lid box is especially designed for filing/microfiche cards. It is supplied with 5 inserts made of Premier Duo™ boxboard. Box fitted with a pull-ring on the front. This box complies with current archiving and conservation standards. Metal-edge construction, supplied ready-assembled. Boxes made from 1300 micron Premier Duo™ Grey/White heavyweight boxboard.

Product code	Internal size mm L x W x H	Internal size inches L x W x H
BXPPLS1126	110 x 260 x 170	4¾ x 10¾ x 6¾

STYLE CODE BB10

Premier Duo™ CD/DVD Metal-Edge Box

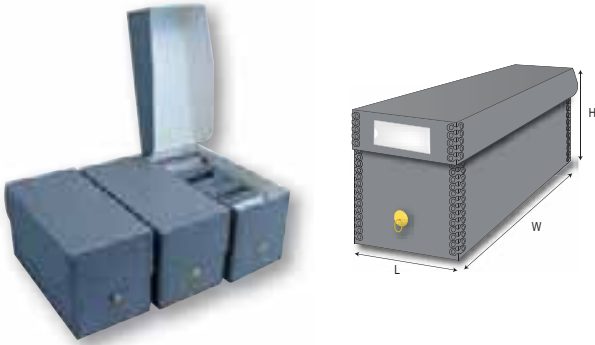

This upright hinged-lid box is designed to store around 90 CD/DVDs in sleeves or 25 to 28 CD in jewel cases. Protect and keep your CDs safe from dust by creating a neutral environment with the Premier Duo™ CD/DVDs box. Supplied with 5 dividers. Boxes made from 1600 micron Premier Duo™ Grey/White heavyweight boxboard. Metal-edge construction, supplied ready-assembled.

Product code	Internal size mm L x W x H	Internal size inches L x W x H
BXP HLS1540	150 x 400 x 200	5 ⁹ / ₃₂ x 15 ¹ / ₄ x 7 ⁷ / ₈
BXP HLS1430	140 x 300 x 160	5 ³³ / ₆₄ x 11 ³ / ₁₆ x 6 ¹³ / ₆₄

STYLE CODE BB11

Premier Duo™ RG Metal-Edge Box



Upright box with hinged lid and flap, for storing documents in 24 x 32cm folders. With a metal-edge construction to reinforce the corner which is invisible from the inside. Fitted with a ring-pull on the front of the box and polypropylene label-holder on front of lid. Made from our 1600 micron Premier Duo™ Grey/White heavyweight boxboard. Supplied ready-assembled.

Product code	Internal size mm L x W x H	Internal size inches L x W x H
BXP HLD2432	335 x 245 x 80	13 ³ / ₁₆ x 9 ⁴ / ₆₄ x 3 ³ / ₃₂
BXP HLD2538	385 x 255 x 80	15 ⁵ / ₃₂ x 10 ³ / ₆₄ x 3 ³ / ₃₂
BXP HLD2733	335 x 275 x 130	13 ³ / ₁₆ x 10 ⁵³ / ₆₄ x 5 ¹ / ₈

STYLE CODE BB20

Premier Duo™ Flute Document Box

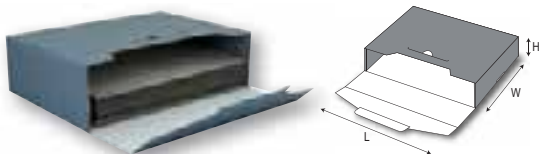

The boxes are made from Premier Duo™ archival fluted boxboard, Grey/White. Tabbed construction, supplied flat-packed. Upright document box for keeping documents in folders. These boxes permit easy access to contents with a fully hinging flap on the long side to allow easy access to contents. An economical box.

Product code	Internal size mm L x W x H	Internal size inches L x W x H	Pack qty
BXCORE2408	335 x 245 x 80	13 ³ / ₁₆ x 9 ⁴ / ₆₄ x 3 ³ / ₃₂	25
BXCORE2410	335 x 245 x 100	13 ³ / ₁₆ x 9 ⁴ / ₆₄ x 3 ¹⁵ / ₁₆	25
BXCORE2405	335 x 245 x 50	13 ³ / ₁₆ x 9 ⁴ / ₆₄ x 1 ³ / ₃₂	25
BXCORE2413	335 x 245 x 130	13 ³ / ₁₆ x 9 ⁴ / ₆₄ x 5 ¹ / ₈	25

STYLE CODE BB12

Premier Buckram Duo™ RG Metal-Edge Box



Upright box with hinged lid and flap for storing documents in 24 x 32cm folders. With a metal-edge construction to reinforce the corner which is invisible from the inside. Fitted with a ring-pull on the front of the box and aluminium label-holder. Boxes made from our 1300 micron Premier Duo™ Grey/White heavyweight boxboard covered with Buckram cloth. Supplied ready-assembled.

2 colours available*: Grey or Black, to be specified when placing order.

Product code	Internal size mm L x W x H	Internal size inches L x W x H
BXBHLD2733	335 x 275 x 130	13 ³ / ₁₆ x 10 ⁵³ / ₆₄ x 5 ¹ / ₈
BXBHLD2432	335 x 245 x 80	13 ³ / ₁₆ x 9 ⁴ / ₆₄ x 3 ³ / ₃₂
BXBHLD2538	385 x 255 x 80	15 ⁵ / ₃₂ x 10 ³ / ₆₄ x 3 ³ / ₃₂

STYLE CODE BB13

Premier Duo™ LH Metal-Edge Box

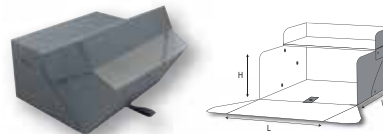

This box is designed to be used horizontally with a hinged lid and drop front allowing good accessibility. Fitted with a cloth pull at the front and a polypropylene label-holder. For documents held in files. Made from 1600 micron Premier Duo™ Grey/White heavyweight boxboard. Metal-edge construction, supplied ready-assembled.

Product code	Internal size mm L x W x H	Internal size inches L x W x H
BXP HLD3040	400 x 300 x 200	15 ³ / ₄ x 11 ³ / ₁₆ x 7 ⁷ / ₈

STYLE CODE BB21

Premier Duo™ Flute Flip-Top Document Box

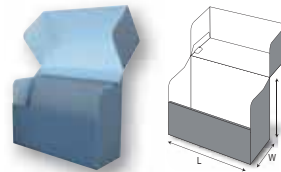

The boxes are made from Premier Duo™ archival fluted boxboard, Grey/White. Tabbed construction, supplied flat-packed. Upright hinged-lid box for archival storage of documents. An economical box. Tabbed construction, supplied flat-packed.

Product code	Internal size mm L x W x H	Internal size inches L x W x H	Pack qty
BXCORE1427	355 x 140 x 270	13 ³ / ₃₂ x 5 ³ / ₆₄ x 10 ⁵ / ₈	25

STYLE CODE BB22

Premier Duo™ Flute Periodicals Box

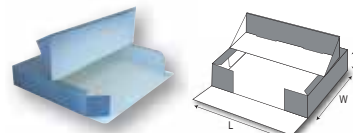

The boxes are made from Premier Duo™ archival fluted boxboard, Grey/White. Upright document storage box for the storage of magazines, periodicals and newspapers. With a hinged lid and flap, tabbed construction, supplied flat-packed. An economical box.

Product code	Internal size mm L x W x H	Internal size inches L x W x H	Pack qty
BXCORE3608	520 x 360 x 80	20 ¹⁵ / ₃₂ x 14 ¹ / ₆₄ x 3 ³ / ₃₂	25

STYLE CODE BB14

Premier Duo™ Metal-Edge BH Box

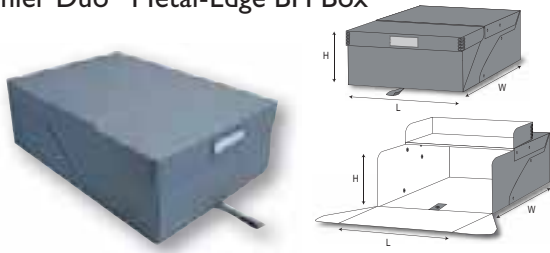

This box is designed to be used horizontally with a hinged lid and drop front allowing good accessibility. This box has been specially adapted for storing herbarium plates. Fitted with a cloth-pull at the front and an epoxy-treated label-holder. Made from 1650 micron Premier Duo™ Grey/White heavyweight boxboard. Metal-edge construction, supplied ready-assembled.

Product code	Internal size mm L x W x H	Internal size inches L x W x H
BXPHLD3049	300 x 490 x 170	11 ³ / ₁₆ x 19 ⁹ / ₆₄ x 6 ¹ / ₁₆
BXPHLD3749	340 x 490 x 170	13 ² / ₆₄ x 19 ⁹ / ₆₄ x 6 ¹ / ₁₆

STYLE CODE BB15

PolypHlute™ Archives Plus Box

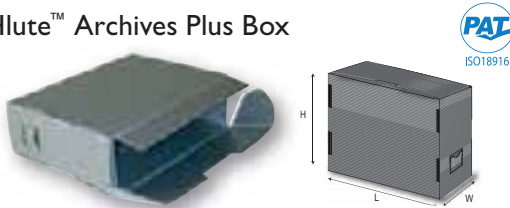

The boxes are made from our PolypHlute™ Fluted Polypropylene grey board.

Based on the PolypHlute™ – Archives Box; the difference is that its opening offers greater accessibility. Holding flap built onto the smaller side. Tabbed construction, supplied flat-packed.

Product code	Internal size mm L x W x H	Internal size inches L x W x H	Pack qty
BXDOCP3305	335 x 50 x 245	13 ³ / ₁₆ x 1 ³ / ₃₂ x 9 ⁴ / ₆₄	10
BXDOCP3315	335 x 150 x 245	13 ³ / ₁₆ x 5 ²⁹ / ₃₂ x 9 ⁴ / ₆₄	10
BXDOCP3310	335 x 100 x 245	13 ³ / ₁₆ x 3 ⁵ / ₁₆ x 9 ⁴ / ₆₄	10

STYLE CODE BB16

PolypHlute™ Disk Box

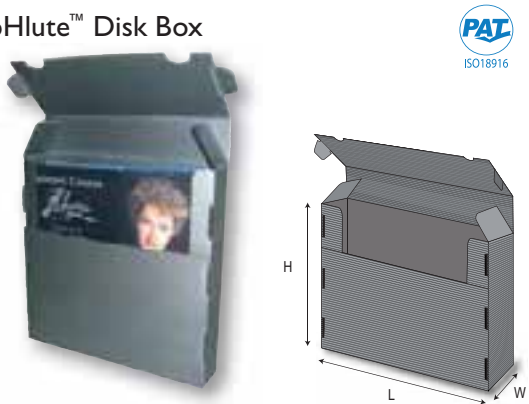

The boxes are made from our PolypHlute™ Fluted Polypropylene grey board. Upright hinged-lid fluted polypropylene box suitable for storing 78 rpm disks. Tabbed construction, supplied flat-packed.

Product code	Internal size mm L x W x H	Internal size inches L x W x H	Pack qty
BXDOCP0078	270 x 50 x 270	10 ⁵ / ₈ x 1 ³ / ₃₂ x 10 ⁵ / ₈	10

STYLE CODE BB17

PolypHlute™ Glass Plates Box

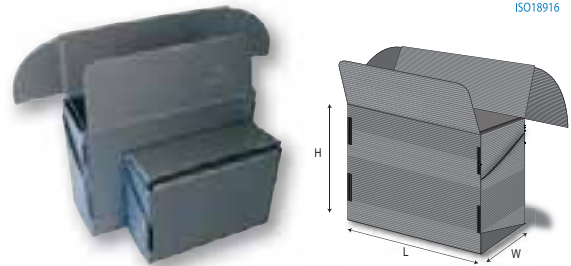

The boxes are made from PolypHlute™ Fluted Polypropylene grey board. Tabbed construction, supplied flat-packed. These boxes are especially designed for storing photographic plates. Triple side walls offering excellent rigidity. The inside is entirely smooth allowing your plates to be filed away in complete safety.

Product code	Internal size mm L x W x H	Internal size inches L x W x H	Pack qty
BXDOCP0018	180 x 70 x 140	7 ³ / ₃₂ x 2 ⁷ / ₁₆ x 5 ³ / ₆₄	10
BXDOCP0025	245 x 95 x 190	9 ⁴ / ₆₄ x 3 ⁷ / ₆₄ x 7 ³ / ₆₄	10
BXDOCP0017	170 x 100 x 120	6 ¹ / ₁₆ x 3 ⁵ / ₁₆ x 4 ²⁹ / ₃₂	10

STYLE CODE BB18

PolypHlute™ Archives Box

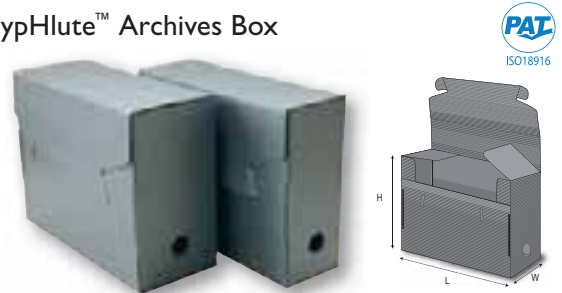

Upright document boxes made from PolypHlute™ Fluted Polypropylene grey board, for keeping documents in folders. With a fully hinging lid on the long side to allow easy access to contents.

An economical box. Tabbed construction, supplied flat-packed.

Product code	Internal size mm L x W x H	Internal size inches L x W x H	Pack qty
BXDOCP3410	340 x 100 x 250	13 ² / ₆₄ x 3 ¹ / ₁₆ x 9 ²⁷ / ₃₂	10
BXDOCP3415	340 x 145 x 250	13 ² / ₆₄ x 5 ⁵ / ₆₄ x 9 ²⁷ / ₃₂	10
BXDOCP0348	340 x 80 x 250	13 ² / ₆₄ x 3 ¹ / ₃₂ x 9 ²⁷ / ₃₂	10

STYLE CODE BB19

PolypHlute™ Graphic Novels Box

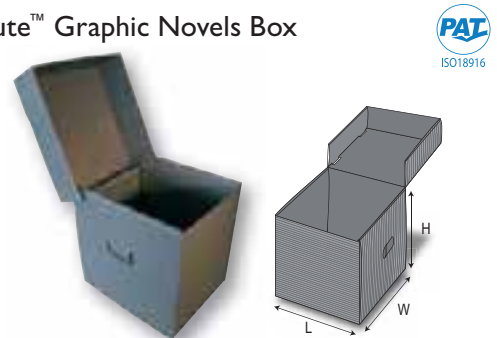

The boxes are made from PolypHlute™ Fluted Polypropylene grey board. Hinged-lid box with double wall construction and integral handles. Suitable for graphic novels. Tabbed construction, supplied flat-packed.

Product code	Internal size mm L x W x H	Internal size inches L x W x H	Pack qty
BXTRUN2430	240 x 300 x 320	9 ² / ₆₄ x 11 ¹³ / ₁₆ x 12 ¹⁹ / ₃₂	10

Hinged-Lid with Carry handle

STYLE CODE CB01

Premier Duo™ Carry Case With Handle

A one-piece box made from Premier Duo™ Archival acid-free and lignin-free boxboard. Designed for storage and transport, they can be stored horizontally or vertically and can be supplied with Premier Duo™ Archival Folders to divide and protect items within the box. This system has been successfully used for the storage of newspapers, parchments, documents, photographs, prints and drawings. The cases have a hinged lid fastened by one or more snap-in plastic clips and have a strong plastic carrying handle.

Specifications

- Made from Premier Duo™ Archival Folding Boxboard
- Supplied flat-packed or ready-assembled
- Colour: Grey/White as standard
- Duke Parchment/White colour available for special order



Applications

- Suitable for the storage of newspapers, parchments, documents, photographs, prints and drawings

Product code	To fit	Colour	Thickness micron	Internal size mm	Internal size inches	RA/FP
BXDOCC6102		Grey/White	1300	460 x 69 x 344	18½ x 2¼ x 13½	FP
BXDOCC6307	Imperial/A1	Grey/White	1300	838 x 66 x 570	33 x 2½ x 22¼	FP
BXDOCC6739*		Grey/White	1300	470 x 80 x 340	18½ x 3¼ x 13½	RA

*Cambridge Newspaper Carry Case shown.

Linked Products: Envelopes p42; Folders p42; Tissue Paper p93, p99-100; Gloves p215.



The Cambridge Newspaper System

This system was the result of using CXD-applied product knowledge and 'lateral' thinking when we were asked by a client to design a new system for storing their newspapers archive.

Previously the storage of bound and boxed newspapers was both expensive and time-consuming. The introduction of the CXD-designed system has made this archival task much less daunting.

This Cambridge Newspaper System makes the handling of dated newspaper editions easier to store, but rigid and light enough to be carried from the library shelf to reader.

The system consists of a Premier™ Carry Case containing four Premier™ Multi-Crease Folders each of which protect 10 or more newspapers editions. It is fastened with two snap-lock clasps on the lid and is supplied with a label and holder for clear identification. The swivel handle allows simple removal from a shelf and a comfortable carrying grip.



BXDOCC6739 Carry Case With Handle*



FDPFFF6738 Four-Flap Folder (p55)

Two-Part Boxes

STYLE CODE DB01

Premier Duo™ Heavy Duty Library, Print and Newspaper Boxes



Originally made for storing newspapers these two-part boxes are extremely strong and rigid. They have double walls on all sides, including the base and lid which have inserts that are snapped or glued into place. They are strong enough to multiple-stack even when heavily loaded. The double wall construction offers extra strength and improved protection against fire and water.

The design of box is particularly suitable for large sizes.

Boxes can be supplied flat-packed or ready-assembled for an additional charge.

NB: Please note that some large boxes can be awkward to construct. We also advise gluing the separate (double thickness) pad into the lid. Please ask for more details.

Specifications

- Made from Premier Duo™ Archival Folding Boxboard
- Supplied flat-packed or ready-assembled
- Colour: Grey/White as standard
- Duke Parchment/White colour available for special order



Applications

- Suitable for archival storage of newspapers, prints, drawings, documents, photographs, textiles and ephemera

Product code	Description	Colour	Thickness micron	Internal size mm	Internal size inches	RA/FP
BXNEWS6315		Grey/White	1300	820 x 590 x 90	32 ³ / ₁₆ x 23 ¹ / ₄ x 3 ³ / ₁₆	FP
BXNEWS4697	Imperial	Grey/White	1300	797 x 623 x 71	31 ³ / ₁₆ x 24 ¹ / ₂ x 2 ¹³ / ₁₆	FP
BXNEWS6312		Grey/White	1300	700 x 570 x 60	27 ⁹ / ₁₆ x 22 ⁷ / ₁₆ x 2 ³ / ₈	FP
BXNEWS3910		Grey/White	1300	640 x 450 x 76	25 ³ / ₁₆ x 17 ¹ / ₁₆ x 3	FP
BXNEWS6531		Grey/White	1300	628 x 518 x 50	24 ³ / ₈ x 20 ³ / ₈ x 1 ⁹ / ₁₆	RA
BXNEWS3191	Half Imperial	Grey/White	1300	617 x 432 x 76	24 ³ / ₁₆ x 17 x 3	FP
BXNEWS6530		Grey/White	1300	597 x 370 x 50	23 ¹ / ₂ x 14 ¹ / ₁₆ x 1 ⁵ / ₁₆	RA
BXNEWS4427		Grey/White	1300	584 x 483 x 76	23 x 19 x 3	FP
BXNEWS6310		Grey/White	1300	500 x 340 x 150	19 ¹¹ / ₁₆ x 13 ³ / ₈ x 5 ⁷ / ₈	FP
BXNEWS6309		Grey/White	1300	405 x 290 x 100	15 ¹⁵ / ₁₆ x 11 ¹ / ₁₆ x 3 ¹⁵ / ₁₆	FP
BXNEWS6279		Grey/White	1300	380 x 156 x 105	14 ¹⁵ / ₁₆ x 6 ¹ / ₈ x 4 ¹ / ₈	FP
BXNEWS6095		Grey/White	1300	340 x 270 x 95	13 ³ / ₈ x 10 ⁵ / ₈ x 3 ³ / ₄	FP

Linked Products: Envelopes/Folders p42; Tissue Paper p93, p99-100; Gloves p215; Plastazote® p120; Wallpaper Sample Box p35 and p46.

STYLE CODE DB02

Premier Duo™ Archival Textile Storage Box



Two-part box with separate lid and base, single-wall construction. Semi-circular thumb cuts in the lid to aid removal and side pull-tabs. Manufactured without metal parts that can snag on the textiles. The boxes are supplied flat-packed for low-cost shipping, space-saving and self-assembly when ready to use.

We are able to assemble these boxes for you at an additional cost.

Specifications

- Premier Duo™ Archival Folding Boxboard
- Colour: Grey/White as standard
- Duke Parchment/White colour available for special order



Product code	Colour	Thickness micron	Size mm	Size inches	RA/FP
BXNEWS6554	Grey/White	1300	762 x 610 x 152	30 x 24 x 6	FP
BXNEWS6555	Grey/White	1300	762 x 457 x 152	30 x 18 x 6	FP
BXNEWS8273	Grey/White	1300	752 x 572 x 55	29 ³ / ₁₆ x 22 ³ / ₁₆ x 2 ¹ / ₁₆	FP

Linked Products: Envelopes/Folders p42; Tissue Paper p93, p99-100; Gloves p215; Full specification on Premier Duo™ Archival Folding Boxboard p110.

STYLE CODE DB03

Lydamore Flat-Packed EcopHant™ Boxes

Recycled Green Archival Storage Boxes

Acid-free, flat-packed green EcopHant™ archival storage boxes offer buyers high-quality conservation storage for a similar price to traditional, non-archival brown chipboard boxes.

The Lydamore range is a strong, modular system made from EcopHant™ recycled boxboard.

The boxes were initially designed and developed to resolve a space problem for one of CXD's existing customers, the Essex Record Office, and is consequently named in honour of their first conservator, Amy Lydamore.

Designed to accommodate most popular document sizes, the boxes have two robust pull tabs for easy handling and removal of the lid. Some boxes feature drop-front options for ease of access to contents. They feature a unique wall-liner that is snapped in place by inert plastic fixings. Lydamore boxes are available in three different styles and eight sizes. They are supplied flat-packed with all the fittings to reduce delivery costs and save on storage space.

Specifications

- Permanent and durable quality ISO 16245-A Type A
- Made from EcopHant™ Recycled Acid-free Boxboard,
- 100% Chemically Purified Wood-free Fibre
- pH7 to 7.5
- Acid-free and Lignin-free
- OBA-free
- Less than 0.0008% reducible sulphur
- Supplied flat-packed
- Colour: Elephant green, colour-fast
- Neutral-sized for water-resistance



Product code	Description	Colour	Thickness micron	Internal size mm	Internal size inches	RA/FP
BXTPLB6741	A4	Elephant Green	1300	340 x 270 x 110	13 ³ / ₁₆ x 10 ⁵ / ₁₆ x 4 ¹ / ₁₆	FP
BXTPLB6742	Foolscap	Elephant Green	1300	390 x 270 x 110	15 ¹ / ₁₆ x 10 ⁵ / ₁₆ x 4 ¹ / ₁₆	FP
BXTPLB6556		Elephant Green	1300	405 x 300 x 120	15 ¹ / ₁₆ x 11 ¹ / ₁₆ x 4 ¹ / ₁₆	FP
BXTPLB6711		Elephant Green	1300	405 x 300 x 180	15 ¹ / ₁₆ x 11 ¹ / ₁₆ x 7 ¹ / ₁₆	FP
BXTPLB6558		Elephant Green	1300	405 x 300 x 60	15 ¹ / ₁₆ x 11 ¹ / ₁₆ x 2 ¹ / ₁₆	FP
BXTPLB6557	Drop-front	Elephant Green	1300	405 x 300 x 90	15 ¹ / ₁₆ x 11 ¹ / ₁₆ x 3 ¹ / ₁₆	FP
BXTPLB6745	Drop-front	Elephant Green	1300	600 x 405 x 90	23 ³ / ₁₆ x 15 ¹ / ₁₆ x 3 ¹ / ₁₆	FP
BXTPLB8517		EcopHant™ Green	1300	390 x 270 x 97	15 ² / ₁₆ x 10 ⁵ / ₁₆ x 3 ¹ / ₁₆	FP
BXTPLB8522		EcopHant™ Green	1300	584 x 443 x 40	22 ¹ / ₁₆ x 17 ¹ / ₁₆ x 1 ¹ / ₁₆	FP

[Linked Products: Lydamore Upright Document Box p23.](#)

Information

What are EcopHant™ boxes?



The EcopHant™ boxes are green in colour and by nature. Conservation By Design aim for zero waste in its box manufacturing by recycling its expensive and high-quality, long fibre, acid-free and lignin-free post-production paper and board waste.

This waste is then made into high-density Superior™ bookbinders millboard and slightly lower density EcopHant™ boxboard using a non-adhesive, board-making machine.

Offering long-term protection from light, dust, fire and water, EcopHant™ is neutral-sized for water-resistance and is colourfast.

This exceptional high-strength green board will outlast regular brown kraft/chipboard boxes and corrugated boxes by decades.



Image courtesy of Essex Record Office



For details of Lydamore Upright Box see p23

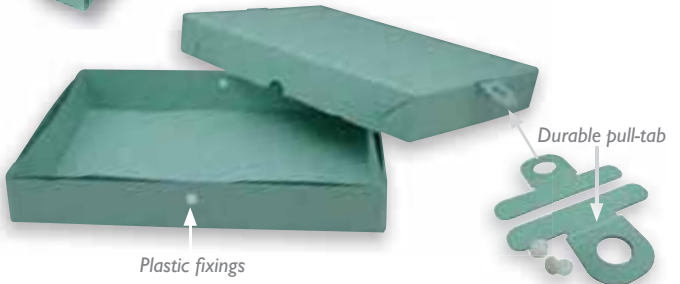

Plastic fixings

Durable pull-tab

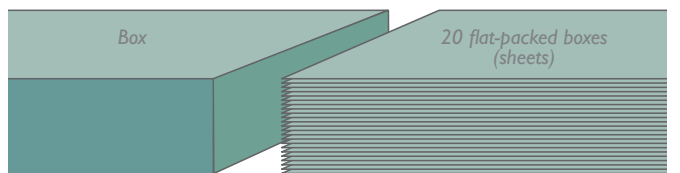

Approximately 20 flat-packed boxes take up the same height as one fully made-up box.

Lydamore Box Easy-assembly procedure



STYLE CODE DB04

EcopHant™ Box and Lid



Extremely strong and rigid, two-part, die-cut and wire-stitched box made from EcopHant™ boxboard. Box and lid supplied ready-assembled.

Ordinary brown kraft lined chipboard boxes, found in many archives, are made from low-grade raw materials of a moderate, low acid pH. These boxes have been used for years by archives because they were the best and only low-cost alternative to a fully specified Premier Duo™ Grade Archival Box. Now there is an alternative, the Green EcopHant™ Archive Box.

Specifications

- Permanent and durable quality ISO 16245-A Type A
- Made from EcopHant™ Recycled Acid-free Boxboard,
- 100% Chemically Purified Wood-free Fibre
- pH7 to 7.5
- Acid-free and Lignin-free
- OBA-free
- Supplied fully-assembled
- Colour: Elephant Green



Applications

- Suitable for archival storage of documents, photographs, prints, negatives, transparencies, drawings and ephemera

Product code	Type	Colour	Thickness micron	Internal size mm	Internal size inches	RA/FP
BXGBWS6223		Elephant Green	1300	290 x 290 x 125	11 ¹ / ₁₆ x 11 ¹ / ₁₆ x 4 ¹ / ₁₆	RA
BXGBWS6187		Elephant Green	1300	310 x 220 x 260	13 ¹ / ₁₆ x 10 ¹ / ₄ x 8 ¹ / ₁₆	RA
BXSMBG3181	A4	Elephant Green	1300	340 x 270 x 95	13 ³ / ₁₆ x 10 ⁵ / ₁₆ x 3 ³ / ₄	RA
BXGBWS6277		Elephant Green	1300	380 x 230 x 120	14 ⁵ / ₁₆ x 9 ¹ / ₁₆ x 4 ¹ / ₄	RA
BXGBWS6886		Elephant Green	1300	380 x 260 x 125	14 ⁵ / ₁₆ x 10 ¹ / ₄ x 4 ¹ / ₁₆	RA
BXGBWS6276		Elephant Green	1300	380 x 300 x 120	14 ⁵ / ₁₆ x 11 ¹ / ₁₆ x 4 ¹ / ₄	RA
BXGBWS6296		Elephant Green	1300	385 x 246 x 110	15 ¹ / ₁₆ x 9 ¹ / ₁₆ x 4 ¹ / ₁₆	RA
BXSMBG3182	Foolscap	Elephant Green	1300	385 x 270 x 110	15 ¹ / ₁₆ x 10 ⁵ / ₁₆ x 4 ¹ / ₁₆	RA
BXGBWS6785		Elephant Green	1300	450 x 120 x 120	17 ¹ / ₁₆ x 4 ³ / ₄ x 4 ¹ / ₄	RA
BXGBWS6374		Elephant Green	1300	457 x 305 x 75	18 x 12 x 2 ¹⁵ / ₁₆	RA
BXGBWS6373		Elephant Green	1300	457 x 305 x 145	18 x 12 x 5 ¹ / ₁₆	RA
BXGBWS6372		Elephant Green	1300	457 x 305 x 250	18 x 12 x 9 ¹ / ₁₆	RA
BXGBWS6775		Elephant Green	1300	463 x 214 x 141	18 ¹ / ₄ x 8 ³ / ₁₆ x 5 ¹ / ₁₆	RA
BXGBWS6773		Elephant Green	1300	695 x 215 x 145	27 ³ / ₁₆ x 8 ³ / ₁₆ x 5 ¹ / ₁₆	RA
BXGBWS6409		EcopHant™ Green	1300	485 x 230 x 145	19 ¹ / ₃₂ x 9 ¹ / ₁₆ x 5 ⁴ / ₆₄	RA
BXGBWS6649		EcopHant™ Green	1300	686 x 584 x 180	27 ¹ / ₆₄ x 22 ²³ / ₆₄ x 7 ¹ / ₃₂	RA
BXGBWS6832		EcopHant™ Green	1300	540 x 430 x 110	21 ¹ / ₆₄ x 16 ⁵⁹ / ₆₄ x 4 ¹ / ₆₄	RA
BXGBWS8533		EcopHant™ Green	1300	1100 x 600 x 235	43 ¹ / ₁₆ x 23 ³ / ₁₆ x 9 ¹ / ₄	RA
BXGBWS8555		EcopHant™ Green	1600	365 x 275 x 100	14 ¹ / ₈ x 10 ⁵⁹ / ₆₄ x 3 ¹ / ₁₆	RA
BXGBWS8556		EcopHant™ Green	1600	365 x 275 x 50	14 ¹ / ₈ x 10 ⁵⁹ / ₆₄ x 1 ¹ / ₃₂	RA

Linked Products: Folders p42, Envelopes p42; Transparent Polyester Pockets p73 ; Mounting Sheets p12; Gloves p215.

STYLE CODE DB05

Premier Duo™ Tabless Box and Lid

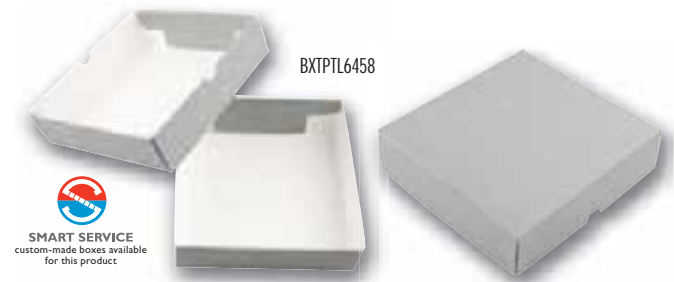

Made from Premier Duo™ Archival acid-free and lignin-free boxboard, this two-part box has double thickness walls on the short end.

Interlocking internal construction with no external tabs. Full depth lid with thumb cuts to aid lid removal.

Specifications

- Made from Premier Duo™ Archival Folding Boxboard
- Supplied flat-packed
- Colour: Grey/White as standard



Applications

- Suitable for archival storage of books, documents, photographs, prints

Product code	Colour	Thickness micron	Internal size mm	Internal size inches	RA/FP
BXTPTL6458	Grey/White	1300	300 x 290 x 80	11 ¹ / ₁₆ x 11 ¹ / ₁₆ x 3 ¹ / ₁₆	FP
BXTPTL6459	Grey/White	1300	300 x 300 x 130	11 ¹ / ₁₆ x 11 ¹ / ₁₆ x 5 ¹ / ₁₆	FP

Linked Products: Envelopes p42; Folders p42; Tissue Paper p93, p99-100; Gloves p215; Full specification on Premier Duo™ Archival Folding Boxboard p110.

Information

Zero Waste Initiative



Conservation By Design manufactures a wide range of Premier Duo™ Grade Boxes, Folders and Envelopes. This process produces a large amount of acid-free and lignin-free paper and board waste. Recycling this waste allows us to produce the new high specification Green EcopHant™ Board.

The recycled board created for these low-cost Green EcopHant™ Archive Boxes is a high-density, hard-pressed material making the boxes stronger, longer lasting and more resistant to fire and flood than any other equivalent box available.

Certain styles of boxes are embossed with a box reference number and year of manufacture. Embossing can be specified to all boxes for special order.

STYLE CODE DB06

Premier Duo™ Tabbed Box and Lid



Made using Premier Duo™ Archival acid-free and lignin-free boxboard this is a double wall design box and lid. Secured using tabs and slots for assembly without the need for wire-stitching or gluing. The boxes are supplied flat-packed for easy, low-cost shipping and space-saving.

Specifications

- Made from Premier Duo™ Archival Folding Boxboard
- Supplied flat-packed
- Colour: Grey/White



Applications

- Suitable for archival storage of books, documents, photographs, prints

Product code	Colour	Thickness micron	Internal size mm	Internal size inches	RA/FP
BXTPTB4670	Grey/White	1300	1040 x 700 x 38	40 ⁹ / ₁₆ x 27 ⁷ / ₁₆ x 1 ¹ / ₂	FP

Linked Products: Envelopes p42; Folders p42; Tissue Paper p93, p99-100; Gloves p215; Full specification on Premier Duo™ Archival Folding Boxboard p110.



STYLE CODE DB07

Premier Duo™ Wire-Stitched Box and Lid



BXPBWS6767

Produced from Premier Duo™ Archival acid-free and lignin-free boxboard. This ready-assembled, two-part, die-cut, brass wire-stitched box and lid offer permanence and durability, for long-life storage.

Specifications

- Made from Premier Duo™ Archival Folding Boxboard
- Wire-stitched, non-rusting brass or stainless steel
- Supplied ready-assembled
- Colour: Grey/White
- Duke Parchment/White colour available for special order



Applications

- Suitable for archival storage of documents, photographs, prints, negatives, transparencies, drawings and ephemera

Product code	Colour	Thickness micron	Internal size mm	Internal size inches	RA/FP
BXPBWS6412	Grey/White	1300	220 x 120 x 90	8 ³ / ₄ x 4 ³ / ₄ x 3 ³ / ₁₆	RA
BXPBWS0878	Grey/White	1300	366 x 260 x 95	14 ¹ / ₁₆ x 10 ¹ / ₄ x 3 ³ / ₄	RA
BXPBWS3487	Grey/White	1300	370 x 270 x 110	14 ¹ / ₁₆ x 10 ⁵ / ₁₆ x 4 ¹ / ₁₆	RA
BXPBWS4405	Grey/White	1300	375 x 375 x 120	14 ³ / ₄ x 14 ³ / ₄ x 4 ³ / ₄	RA
BXPBWS6767	Grey/White	1300	375 x 300 x 100	14 ³ / ₄ x 11 ¹³ / ₁₆ x 3 ¹⁵ / ₁₆	RA
BXPBWS3182	Grey/White	1300	385 x 270 x 110	15 ³ / ₁₆ x 10 ⁵ / ₁₆ x 4 ¹ / ₁₆	RA
BXPBWS6783	Grey/White	1000	382 x 302 x 115	15 x 11 ¹ / ₈ x 4 ¹ / ₂	RA
BXPBWS6308*	Grey/White	1300	400 x 300 x 185	15 ³ / ₄ x 11 ¹³ / ₁₆ x 7 ⁷ / ₁₆	RA
BXPBWS0876	Grey/White	1300	400 x 318 x 178	15 ³ / ₄ x 12 ¹ / ₂ x 7	RA
BXPBWS6497	Grey/White	1300	406 x 229 x 75	16 x 9 x 2 ³ / ₁₆	RA
BXPBWS6496	Grey/White	1300	406 x 229 x 140	16 x 9 x 5 ¹ / ₂	RA
BXPBWS1705	Grey/White	1300	420 x 200 x 125	16 ¹ / ₁₆ x 7 ⁷ / ₁₆ x 4 ¹⁵ / ₁₆	RA
BXPBWS6024	Grey/White	1300	430 x 310 x 30	16 ³ / ₁₆ x 12 ³ / ₁₆ x 1 ¹ / ₁₆	RA
BXPBWS5060	Grey/White	1300	438 x 330 x 147	17 ¹ / ₄ x 13 x 5 ¹³ / ₁₆	RA
BXPBWS6311*	Grey/White	1300	590 x 400 x 150	23 ¹ / ₄ x 15 ¹ / ₄ x 5 ⁵ / ₈	RA
BXPBWS6649	Grey/White	1300	686 x 584 x 180	27 x 23 x 7 ¹ / ₁₆	RA
BXPBWS6453*	Grey/White	1300	700 x 570 x 100	27 ⁷ / ₁₆ x 22 ⁷ / ₁₆ x 3 ¹⁵ / ₁₆	RA
BXPBWS6313*	Grey/White	1300	700 x 570 x 160	27 ⁷ / ₁₆ x 22 ⁷ / ₁₆ x 6 ⁷ / ₁₆	RA
BXPBWS6063	Grey/White	1300	762 x 534 x 152	30 x 21 x 6	RA
BXPBWS6384*	Grey/White	1300	780 x 590 x 100	30 ¹ / ₁₆ x 23 ¹ / ₄ x 3 ¹⁵ / ₁₆	RA
BXPBWS6314*	Grey/White	1300	780 x 590 x 175	30 ¹ / ₁₆ x 23 ¹ / ₄ x 6 ⁷ / ₁₆	RA
BXPBWS6582*	Grey/White	1300	850 x 650 x 80	33 ³ / ₁₆ x 25 ⁵ / ₁₆ x 3 ¹ / ₈	RA
BXPBWS6037	Grey/White	1300	1022 x 762 x 100	40 ¹ / ₄ x 30 x 3 ¹⁵ / ₁₆	RA
BXPBWS6505	Grey/White	1300	1188 x 755 x 130	46 ⁸ / ₁₆ x 29 ² / ₁₆ x 5 ¹ / ₈	RA
BXPBWS6750	Grey/White	1300	445 x 318 x 290	17 ³ / ₁₆ x 12 ³ / ₁₆ x 11 ⁷ / ₁₆	RA
BXPBWS6751	Grey/White	1300	445 x 344 x 290	17 ³ / ₁₆ x 13 ³ / ₁₆ x 11 ⁷ / ₁₆	RA
BXPBWS6852	Grey/White	1300	380 x 160 x 110	14 ¹ / ₁₆ x 6 ¹ / ₁₆ x 4 ¹ / ₁₆	RA
BXPBWS8096	Grey/White	1300	190 x 125 x 95	7 ³ / ₁₆ x 4 ⁹ / ₁₆ x 3 ⁷ / ₁₆	RA
BXPBWS8257	Duke Parchment	1300	397 x 263 x 100	15 ⁷ / ₁₆ x 10 ² / ₁₆ x 3 ¹⁵ / ₁₆	RA

*Stitched box with cruciform liner and Newspaper style lid (DB01 Style)

STYLE CODE DB08

Premier Duo™ Large Storage and Transit Box



BXPBWS6418

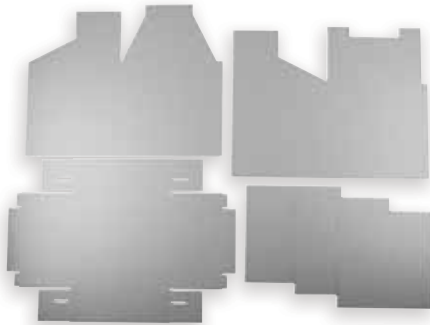

BXPBWS6418 Flat-packed

These large boxes were designed for transport and storage. They are a two-part design. The side wall of the box is stitched with brass wire and has a crash-lock flat base. They feature an insert pad in the base to spread the load and prevent the crash-lock base being forced open.

This was an innovation designed by CXD for use in the Telescopic Cube Tubes. The lid is constructed using tabs and slots. The box ships flat for self-assembly.

If the boxes are stacked on top of each other we recommend the addition of an extra inner wall made from double wall EB Premier Duo™ Archival Fluted Boxboard.

Product code	Colour	Thickness micron	Internal size mm	Internal size inches	Lid depth mm	RA/FP
BXPBWS6418	Grey/White	1300	475 x 470 x 475	18 ¹¹ / ₁₆ x 18 ¹ / ₂ x 18 ¹¹ / ₁₆	162	FP
BXPBWS6452	Grey/White	1300	305 x 254 x 330	12 x 10 x 13	50	FP

STYLE CODE DB22

Polyplute™ Container Box

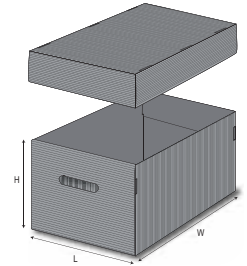

The boxes are made from Polyplute™ Fluted Polypropylene grey board. Tabbed construction, supplied flat-packed. Record storage-fluted polypropylene box with double walls and integral handles. Being both water and weatherproof, file boxes, periodicals, books or other printed matter can be transported and moved outside. The BXCART0044 box allows 3 x BXDOCP3415 boxes to be stored and transported.

Product code	Internal size mm L x W x H	Internal size inches L x W x H
BXCART0044	350 x 440 x 260	13 ²⁵ / ₃₂ x 17 ²¹ / ₆₄ x 10 ¹⁵ / ₆₄
BXCART0037	270 x 370 x 270	10 ⁵ / ₈ x 14 ⁴ / ₁₆ x 10 ⁵ / ₈
BXCART0072	470 x 740 x 170	18 ¹ / ₂ x 29 ³ / ₆₄ x 6 ¹ / ₁₆
BXCART0032	195 x 320 x 135	7 ⁴ / ₆₄ x 12 ¹⁹ / ₃₂ x 5 ³ / ₁₆

STYLE CODE DB22

Timecare® Carry Cube



A superior design of storage and transfer box, featuring unique built-in carry handles which tuck under the lid when not in use. With the exception of the lid, the box has a double wall NE flute construction throughout. It is made from CXD Premier Duo™ Fluted Archival Boxboard, which is a corrugated board of the highest specification, designed for the long-term, safe storage of documents, photographs and textiles.

The size is suitable for a wide variety of uses including the storage of hats. In addition, should they require transportation, each Timecare® Carry Cube will hold six Timecare® Library Ringbinder boxes. (Outer box only supplied.)

Overall Outside Dimension with lid: L 398 x W 385 x H 380mm
Overall Outside Dimension without lid: L 380 x W 380 x H 380mm

Product code	Material	Internal size mm	Internal size inches
BXFCCU8616	NE Flute (2585 micron) Premier Fluted Boxboard	365 x 370 x 365	14 ³ / ₈ x 14 ³ / ₈ x 14 ³ / ₈

STYLE CODE DB10

Premier Duo™ ST Model Metal-Edge Box



Two-part box with separate lid. Designed for archival storage of documents and photographs, stored in individual folders. 18 sizes for 10 x 15cm up to 80 x 120cm documents.

An economical box offering archival protection for collections. Boxes made from 1300 micron Premier Duo™ Grey/White heavyweight boxboard. Metal-edge construction, supplied ready-assembled.

Product code	Internal size mm L x W x H	Internal size inches L x W x H
BXPTST1015	110 x 155 x 55	4 ² / ₆₄ x 6 ¹ / ₆₄ x 2 ¹ / ₆₄
BXPTST1318	150 x 200 x 80	5 ⁹ / ₃₂ x 7 ⁷ / ₆ x 3 ³ / ₃₂
BXPTST1824	200 x 260 x 80	7 ⁷ / ₆ x 10 ¹⁵ / ₆₄ x 3 ³ / ₃₂
BXPTST2025	220 x 270 x 80	8 ² / ₃₂ x 10 ⁶ / ₆₄ x 3 ³ / ₃₂
BXPTST2130	230 x 330 x 55	9 ¹ / ₁₆ x 12 ⁶ / ₆₄ x 2 ¹ / ₆₄
BXPTST2430	260 x 320 x 80	10 ¹⁵ / ₆₄ x 12 ¹⁹ / ₃₂ x 3 ³ / ₃₂
BXPTST3040	325 x 420 x 55	12 ²⁵ / ₆₄ x 16 ¹⁷ / ₃₂ x 2 ¹ / ₆₄
BXPTST3042	320 x 440 x 55	12 ¹⁹ / ₃₂ x 17 ² / ₆₄ x 2 ¹ / ₆₄
BXPTST4050	425 x 520 x 55	16 ⁶ / ₆₄ x 20 ⁵ / ₃₂ x 2 ¹ / ₆₄
BXPTST5060	525 x 620 x 55	20 ⁴ / ₆₄ x 24 ¹³ / ₃₂ x 2 ¹ / ₆₄
BXPTST5065	525 x 670 x 55	20 ⁴ / ₆₄ x 26 ³ / ₆ x 2 ¹ / ₆₄
BXPTST6080	620 x 820 x 55	24 ¹³ / ₃₂ x 32 ² / ₃₂ x 2 ¹ / ₆₄
BXPTST7100	720 x 1020 x 55	28 ¹¹ / ₃₂ x 40 ⁵ / ₃₂ x 2 ¹ / ₆₄
BXPTST7130	700 x 1300 x 130	27 ⁷ / ₁₆ x 51 ³ / ₁₆ x 5 ¹ / ₆
BXPTST2535	240 x 340 x 125	9 ⁹ / ₆₄ x 13 ³ / ₆₄ x 4 ⁹ / ₆₄
BXPTST3555	340 x 540 x 145	13 ³ / ₆₄ x 21 ¹ / ₆₄ x 5 ⁵ / ₆₄
BXPTST3535	340 x 340 x 125	13 ³ / ₆₄ x 13 ³ / ₆₄ x 4 ⁹ / ₆₄
BXPTST8120	820 x 1220 x 40	32 ² / ₃₂ x 48 ¹ / ₃₂ x 1 ³ / ₆₄

STYLE CODE DB11

Premier Duo™ D Metal-Edge Disc Box

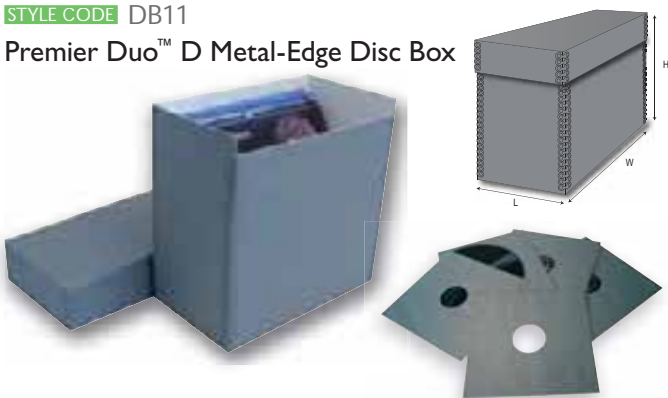

Upright two-part box with separate shallow-depth lid especially designed for storing 33 and 78 rpm discs vertically. This box allows you to store around 30 discs in sleeves. Made from 1600 micron Premier Duo™ Grey/White heavyweight boxboard. Metal-edge construction, supplied ready-assembled.

For record sleeves for 33, 45 and 78 rpm discs, see page 50.

Product code	Internal size mm L x W x H	Internal size inches L x W x H
BXPTPM7800	155 x 275 x 275	6 ¹ / ₆₄ x 10 ³ / ₆₄ x 10 ³ / ₆₄
BXPTPM3300	155 x 330 x 330	6 ¹ / ₆₄ x 12 ² / ₆₄ x 12 ² / ₆₄
BXPTPM4500	155 x 200 x 200	6 ¹ / ₆₄ x 7 ¹ / ₆ x 7 ¹ / ₆

STYLE CODE DB12

Premier Duo™ STDIA Metal-Edge Box

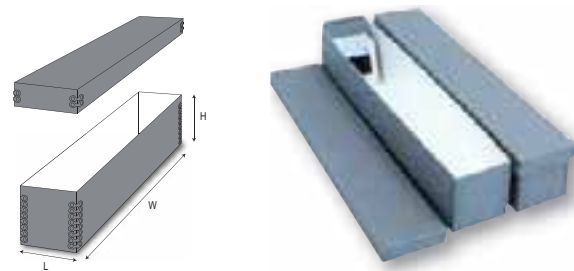

Box with separate shallow-depth lid, designed to hold 5 x 5cm slides. Supplied with 10 dividers. Holds approximately 160 slides. Made from 1000 micron Premier Duo™ Grey/White boxboard. Metal-edge construction, supplied ready-assembled.

Product code	Description	Internal size mm L x W x H	Internal size inches L x W x H
BXPTPM5532	Set of 5 boxes	55 x 320 x 60	2 ¹ / ₆₄ x 12 ¹⁹ / ₃₂ x 2 ³ / ₆₄

STYLE CODE DB13

Premier Duo™ SVDIA and CDIA Metal-Edge Box

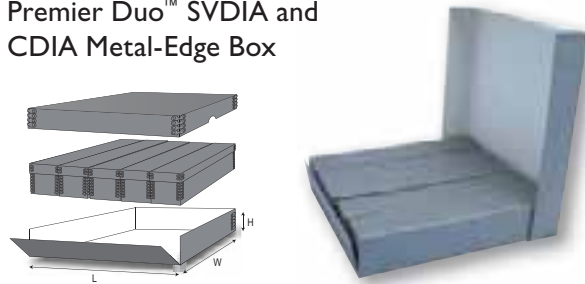

Master Unit Box with separate full-depth, lift-off lid. Box with one side drop-front to allow easy access of contents. It is designed to hold 5 internal boxes (BXPTPM5532), giving a total storage capacity of approximately 800 slides in board or plastic mounts. Made from 1300 micron Premier Duo™ Grey/White heavyweight boxboard. Metal-edge construction, supplied ready-assembled.

Product code	Description	Internal size mm L x W x H	Internal size inches L x W x H
BXMUDI5000	SVDIA – External box can hold a set of 5 internal boxes (BXPTPM5532)	325 x 355 x 70	12 ⁵ / ₆₄ x 13 ³ / ₃₂ x 2 ⁷ / ₄
BXMUCD5500	CDIA – External box with a set of 5 internal boxes	325 x 355 x 70	12 ⁵ / ₆₄ x 13 ³ / ₃₂ x 2 ⁷ / ₄

STYLE CODE DB14

Premier Duo™ Metal-Edge Audio Cassette Box

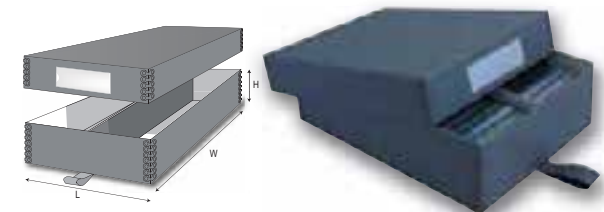

Box with a separate shallow-depth, lift-off lid for storage of audio cassettes. Fitted with a cotton pull-tab on front base of box and label-holder on lid. Made from 1600 micron Premier Duo™ Grey/White heavyweight boxboard. Metal-edge construction, supplied ready-assembled.

Product code	Internal size mm L x W x H	Internal size inches L x W x H
BXPTPM2432	235 x 320 x 90	9 ¹ / ₄ x 12 ¹ / ₃₂ x 3 ⁵ / ₆₄

STYLE CODE DB15

Premier Duo™ Metal-Edge Video Cassette Box

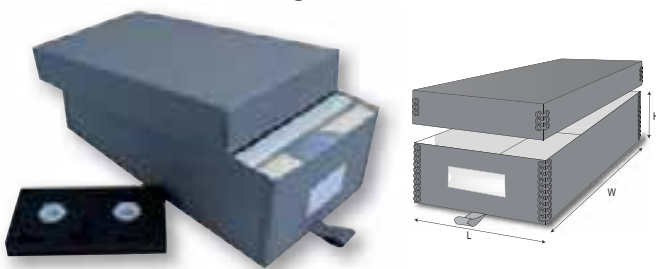

Box with a separate shallow-depth, lift-off lid for storage of video cassettes. Fitted with a cotton pull-tab and label-holder on front base of box. Made from 1600 micron Premier Duo™ Grey/White heavyweight boxboard. Metal-edge construction, supplied ready-assembled.

Product code	Internal size mm L x W x H	Internal size inches L x W x H
BXPTPM2040	200 x 400 x 130	7 ⁷ / ₈ x 15 ³ / ₄ x 5 ¹ / ₈

STYLE CODE DB16

Premier Duo™ Metal-Edge Postcard Box

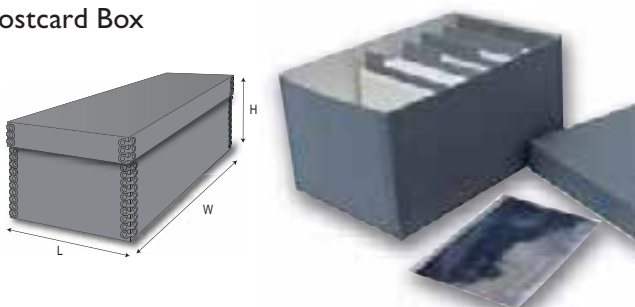

Two-part box with separate shallow-depth, lift-off lid designed for archiving postcard collections – format 105 x 150mm. Its storage capacity is about 250 postcards. Supplied with set of dividers made by acid-free board for topical classification. Metal-edge construction, supplied ready-assembled.

Boxes made from 1300 micron Premier Duo™ Grey/White heavyweight boxboard.

Product code	Internal size mm L x W x H	Internal size inches L x W x H
BXPTPM1115	160 x 250 x 130	6 ¹ / ₄ x 9 ⁷ / ₃₂ x 5 ¹ / ₈
BXPTPM2115*	160 x 250 x 130	6 ¹ / ₄ x 9 ⁷ / ₃₂ x 5 ¹ / ₈

*Supplied without dividers

 *Linked Products: Polyester postcard pockets p70.*

STYLE CODE DB17

Premier Duo™ Metal-Edge Microfiche Box

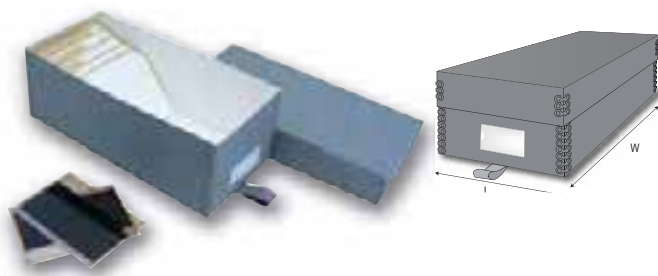

Two-part box with separate shallow-depth, lift-off lid for classification of sleeved microfilms. Fitted with cotton pull-strap and label-holder on front of box. Supplied with a set of 10 x 350gsm Heritage Archival pHotokraft™ 350gsm Duke Parchment paper dividers.

Microfilm sleeve, reference FDAWNFI611. Also see pHoton™ Timelock's p66.

Product code	Description	Internal size mm L x W x H	Internal size inches L x W x H
BXPTPM1633	Box and Dividers	165 x 335 x 130	6 ¹ / ₂ x 13 ³ / ₁₆ x 5 ¹ / ₈
BXPTPM1612	Set of 5 Dividers	160 x 120	6 ¹ / ₄ x 4 ²³ / ₃₂

STYLE CODE DB18

Premier Buckram Duo™ STP Metal-Edge Photo Box

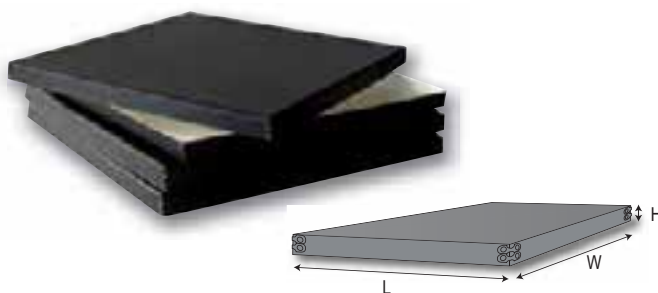

Stylish two-part box with separate full-depth lid designed for archiving photographs; 7 sizes available. An economical box offering archival protection for collections. Boxes made from 1300 micron Premier Buckram Duo™ Grey/White heavyweight boxboard covered with Buckram cloth.

2 colours available*: Grey or Black, to be specified when placing order.

Product code	Internal size mm L x W x H	Internal size inches L x W x H
BXBTPM1318	150 x 200 x 20	5 ²⁹ / ₃₂ x 7 ⁷ / ₈ x ²⁵ / ₃₂
BXBTPM1824	200 x 260 x 20	7 ⁷ / ₈ x 10 ¹⁵ / ₆₄ x ²⁵ / ₃₂
BXBTPM2430	260 x 320 x 20	10 ¹⁵ / ₆₄ x 12 ¹⁹ / ₃₂ x ²⁵ / ₃₂
BXBTPM3040	320 x 420 x 20	12 ¹⁹ / ₃₂ x 16 ¹⁷ / ₃₂ x ²⁵ / ₃₂
BXBTPM1521	170 x 230 x 20	6 ¹¹ / ₁₆ x 9 ¹ / ₁₆ x ²⁵ / ₃₂
BXBTPM2130	230 x 330 x 20	9 ¹ / ₁₆ x 12 ²³ / ₆₄ x ²⁵ / ₃₂

STYLE CODE DB19

Premier Duo™ STP Metal-Edge – Photo Print

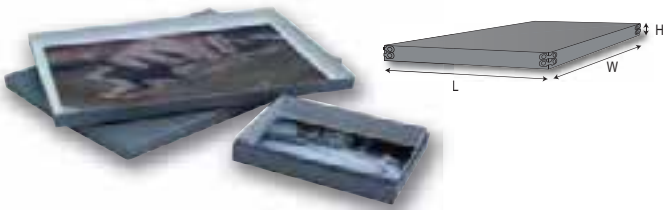

Two-part box with separate full-depth lid designed for archiving photographs; available in 11 sizes. An economical box offering archival protection for collections. Boxes made from 1300 micron Premier Duo™ Grey/White heavyweight boxboard. Metal-edge construction, supplied ready-assembled.

Product code	Internal size mm L x W x H	Internal size inches L x W x H
BXPTPM2430	260 x 320 x 20	10 ¹ / ₄ x 12 ¹ / ₂ x 2 ⁵ / ₃₂
BXPTPM1824	200 x 260 x 20	7 ⁷ / ₈ x 10 ¹ / ₄ x 2 ⁵ / ₃₂
BXPTPM3400	320 x 420 x 20	12 ¹ / ₂ x 16 ¹ / ₂ x 2 ⁵ / ₃₂
BXPTPM3000	320 x 440 x 20	12 ¹ / ₂ x 17 ¹ / ₂ x 2 ⁵ / ₃₂
BXPTPM3001	340 x 500 x 20	13 ² / ₄ x 19 ¹ / ₁₆ x 2 ⁵ / ₃₂
BXPTPM2000	440 x 620 x 20	17 ¹ / ₄ x 24 ¹ / ₂ x 2 ⁵ / ₃₂
BXPTPM3046	310 x 470 x 20	12 ¹ / ₄ x 18 ¹ / ₂ x 2 ⁵ / ₃₂
BXPTPM4050	425 x 520 x 20	16 ⁴ / ₁₆ x 20 ¹ / ₂ x 2 ⁵ / ₃₂
BXPTPM4000	230 x 330 x 20	9 ¹ / ₁₆ x 12 ⁶ / ₁₆ x 2 ⁵ / ₃₂
BXPTPM5000	170 x 230 x 20	6 ¹ / ₁₆ x 9 ¹ / ₁₆ x 2 ⁵ / ₃₂
BXPTPM1318	150 x 200 x 20	5 ⁷ / ₃₂ x 7 ⁷ / ₈ x 2 ⁵ / ₃₂

STYLE CODE DB20

Premier Duo™ Metal-Edge Film Box

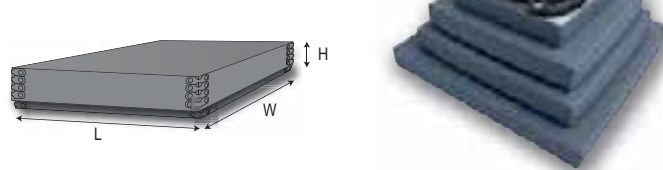

Two-part box with separate full-depth, lift-off lid for storage of cinema reel film. Made from 1300 micron Premier Duo™ Grey/White heavyweight boxboard. Metal-edge construction, supplied ready-assembled.

Product code	Internal size mm L x W x H	Internal size inches L x W x H
BXPTPM2020	200 x 200 x 40	7 ⁷ / ₈ x 7 ⁷ / ₈ x 1 ³ / ₄
BXPTPM2727	270 x 270 x 40	10 ⁵ / ₈ x 10 ⁵ / ₈ x 1 ³ / ₄
BXPTPM3030	300 x 300 x 40	11 ¹ / ₁₆ x 11 ¹ / ₁₆ x 1 ³ / ₄
BXPTPM3737	370 x 370 x 40	14 ³ / ₁₆ x 14 ³ / ₁₆ x 1 ³ / ₄

STYLE CODE DB23

PolypHlute™ – Textile Box



The boxes are made from PolypHlute™ Fluted Polypropylene grey board. Tabbed construction, supplied flat-packed. Fluted polypropylene box with separate lift-off lid. With double walls and fitted with handle on short side of base. Suitable for textiles, dresses, suits and garments.

Product code	Internal size mm L x W x H	Internal size inches L x W x H
BXFTPH1258	550 x 1170 x 150	21 ¹ / ₂ x 46 ¹ / ₁₆ x 5 ⁷ / ₃₂
BXFTPH1480	800 x 1400 x 150	31 ¹ / ₂ x 55 ⁵ / ₈ x 5 ⁷ / ₃₂
BXFTPH7050	495 x 700 x 240	19 ³ / ₁₆ x 27 ¹ / ₁₆ x 9 ⁷ / ₁₆
BXFTPH5314	1385 x 530 x 240	54 ¹ / ₃₂ x 20 ⁵ / ₁₆ x 9 ⁷ / ₁₆

STYLE CODE DB21

Premier Duo™ SV Metal-Edge Box

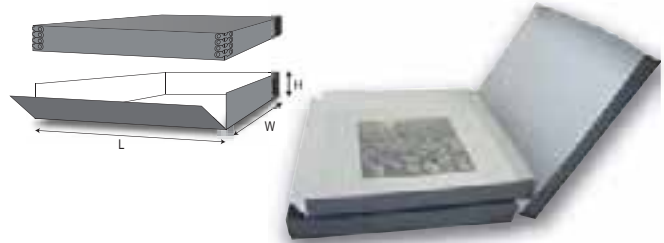

Box with separate lift-off lid, with one side drop-front to allow access to contents. Boxes made from 1300 micron Premier Duo™ Grey/White heavyweight boxboard. Metal-edge construction, supplied ready-assembled.

Product code	Internal size mm L x W x H	Internal size inches L x W x H
BXDFNG3042	440 x 320 x 55	17 ¹ / ₄ x 12 ¹ / ₂ x 2 ¹ / ₄
BXDFNG2430	320 x 260 x 80	12 ¹ / ₂ x 10 ¹ / ₄ x 3 ¹ / ₂
BXDFNG3040	420 x 325 x 55	16 ¹ / ₂ x 12 ⁵ / ₁₆ x 2 ¹ / ₄
BXDFNG4050	520 x 425 x 55	20 ¹ / ₂ x 16 ⁴ / ₁₆ x 2 ¹ / ₄
BXDFNG5060	620 x 525 x 55	24 ¹ / ₂ x 20 ⁴ / ₁₆ x 2 ¹ / ₄
BXDFNG6080	820 x 620 x 55	32 ¹ / ₂ x 24 ¹ / ₂ x 2 ¹ / ₄

Information

The Nicholas Hadgraft Scholarship

Created in 2005, the scholarship is an award of £1500 towards the cost of attending the Montefiascone Book Conservation Summer School held each year in the Medieval Hill Town of Montefiascone, located between Rome and Siena.

The scholarship is offered in memory of Dr Nicholas Hadgraft, a good friend of Conservation By Design who died tragically in 2004. Nicholas was a fellow of the University of the Arts London and a key collaborator on the 'Squelch Drying' technique devised by Stuart Welch (the founder of CXD), the most effective way to date of drying valuable rare books. For more details, see www.cxdtd.com www.monteproject.com

STYLE CODE DB09

Premier Duo™ Wallpaper Sample Book Storage Box and Multi-Crease Wrapper

Produced originally for the storage and protection of wallpaper sample books (e.g. Sandersons), this very sturdy box is based on our Newspaper Box, but is deeper and also features a 1300 micron wrapper with multi-creases and cotton tape tying slots. This wrapper is designed to enclose snugly the volume and facilitates lifting it safely out of the storage box. Sufficient space is left either side of the wrapper to allow easy access for lifting. To stop the package sliding about in the box Plastazote® blocks or other packing can be inserted into the four corners. We can supply four small boxes or Plastazote® blocks if required.

Product code	Colour	Thickness micron	Internal size inches	Internal size mm	RA/FP
BXNEWS3517	Grey/White	1300	26 x 21 ¹ / ₂ x 31 ¹ / ₁₆	660 x 550 x 100	FP

Linked Products: Wrapper, FDMCWR3496 and FDMCWR4729 p46; Folders section p42; Plastazote® p120.

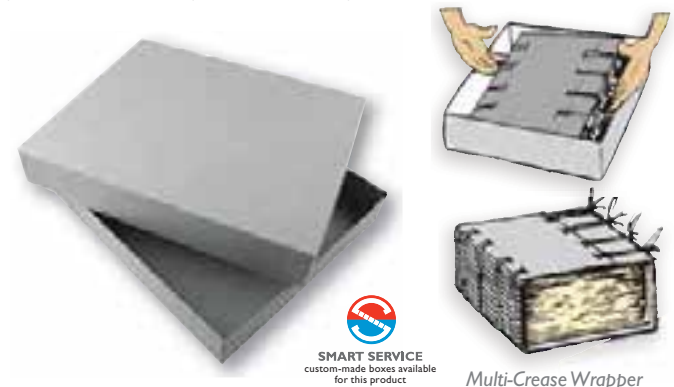

Multi-Crease Wrapper

Drop Wall Boxes

STYLE CODE EB01

Premier Duo™ Palm Leaf Storage Box Wrapper

This complex box was designed in conjunction with Deborah Farnell of Cambridge University Library for the protection of rare and delicate 'palm leaf' manuscripts. The brief was to make a box that gave maximum protection and ease of access to the manuscripts. It is a two-part box with a full-depth lid. The base has two wide double wall 'L' shaped sides which are mitred and hinged on the short sides. When open this gives complete access for handling and when closed offers superb protection of the delicate edges of the palm leaf pages which are held between wooden boards.

The same design of box can be applied to other delicate objects and using the parametric design on our 'Drop-Wall Smart Box™' Kasemake CXD computerised boxmaker we can produce boxes to virtually any size.



Applications

- Palm leaf books and other delicate objects
- Size to suit your requirements, prices on application



Product code	Colour	Thickness micron	Size mm	Size inches
SBPALM8585	Grey/White	650	186 x 117 x 20	7 ³ / ₆₄ x 4 ³ / ₆₄ x 0 ² / ₃₂

STYLE CODE EB02

Premier Duo™ Book Storage Box

Drop-spine folder box produced originally for the storage and protection of books. Made in 650 micron Premier Duo™ Grey/White boxboard. Supplied flat-packed.

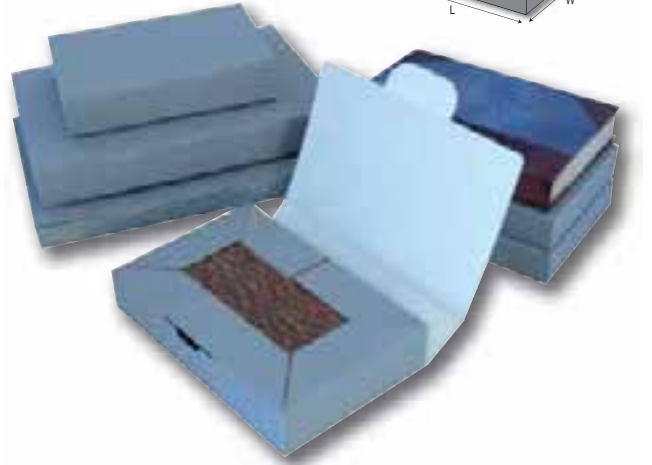
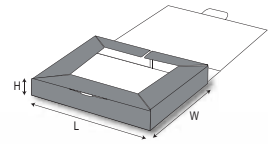

Product code	Internal size mm L x W x H	Internal size inches L x W x H
BXPDL1118	185 x 115 x 30	7 ⁷ / ₃₂ x 4 ¹ / ₃₂ x 1 ¹ / ₁₆
BXPDL3213	200 x 130 x 30	7 ⁷ / ₁₆ x 5 ¹ / ₁₆ x 1 ¹ / ₁₆
BXPDL4213	200 x 130 x 40	7 ⁷ / ₁₆ x 5 ¹ / ₁₆ x 1 ³ / ₁₆
BXPDL3221	220 x 140 x 30	8 ² / ₃₂ x 5 ³ / ₆₄ x 1 ¹ / ₁₆
BXPDL4221	220 x 140 x 40	8 ² / ₃₂ x 5 ³ / ₆₄ x 1 ³ / ₁₆
BXPDL4241	245 x 160 x 40	9 ⁴ / ₆₄ x 6 ³ / ₆₄ x 1 ³ / ₁₆
BXPDL3241	245 x 160 x 30	9 ⁴ / ₆₄ x 6 ³ / ₆₄ x 1 ¹ / ₁₆
BXPDL5241	245 x 160 x 50	9 ⁴ / ₆₄ x 6 ³ / ₆₄ x 1 ³ / ₃₂
BXPDL4271	270 x 175 x 40	10 ⁵ / ₁₆ x 6 ⁵ / ₆₄ x 6 ⁵ / ₆₄
BXPDL3271	270 x 175 x 30	10 ⁵ / ₁₆ x 6 ⁵ / ₆₄ x 1 ¹ / ₁₆

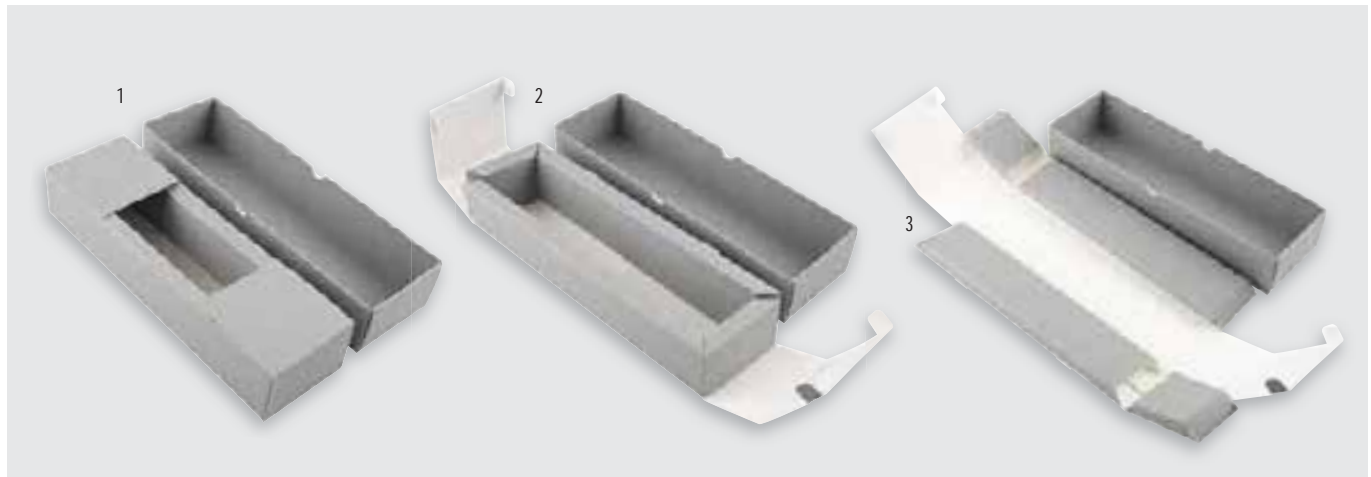

Window Boxes

STYLE CODE FB01

Premier Duo™ Window Box

The Premier Duo™ Window Box comes in four parts: base, lid, polyester sheet and base insert pad. Each box has two thumb cuts in the lid on the long sides. The lids have a viewing square with radiused corners, covered with transparent polyester inside the lid.

The polyester pieces are supplied separately for you to insert and require no adhesive. The box base and lid are constructed with double walls for greater strength and solidity.

The boxes are supplied flat-packed for easy, low-cost shipping and space-saving. Self-assemble when ready to use. If requested we can supply cut-to-size inserts using a variety of useful products including: Plastazote®, Corrosion Intercept® Foam, CXD Charcoal Cloth® and Silica Gel.

Specification

- Made from 650 micron Premier Duo™
- Supplied flat-packed
- Colour: Grey/White as standard
- Duke Parchment/White colour available for special order



Application

- Suitable for archival storage of a variety of items that need to be viewed through the lid
- Originally designed for geological specimens but has proven useful for a wide variety of museum objects including the protection of oxygen-free storage bags from puncture while still allowing visible inspection of the contents without removal from the box.

Linked Products: Plastazote® p120; CXD Charcoal Cloth™ p107, Silica Gel p190, p189-190.



Product code	Colour	Thickness micron	Size mm	Size inches	RA/FP
BXPWBX5021	Grey/White	650	100 x 60 x 40	3 ¹⁵ / ₁₆ x 2 ³ / ₈ x 1 ¹ / ₁₆	FP
BXPWBX5213	Grey/White	650	120 x 100 x 55	4 ³ / ₄ x 3 ¹⁵ / ₁₆ x 2 ¹ / ₁₆	FP
BXPWBX5022	Grey/White	650	120 x 100 x 60	4 ³ / ₄ x 3 ¹⁵ / ₁₆ x 2 ³ / ₈	FP
BXPWBX5023	Grey/White	650	180 x 100 x 80	7 ¹ / ₁₆ x 3 ¹⁵ / ₁₆ x 3 ¹ / ₈	FP
BXPWBX5025	Grey/White	650	240 x 200 x 120	9 ⁷ / ₁₆ x 7 ⁷ / ₈ x 4 ¹ / ₄	FP
BXPWBX5214	Grey/White	650	60 x 50 x 40	2 ³ / ₈ x 1 ⁹ / ₁₆ x 1 ¹ / ₁₆	FP
BXPWBX8140	Grey/White	650	150 x 150 x 40	5 ⁷ / ₃₂ x 5 ⁷ / ₃₂ x 1 ¹ / ₁₆	FP

STYLE CODE FB02

Premier Duo™ 3D Metal-Edge Window Box

Master Unit box with a separate transparent lid made of thick polyester and Premier Duo™ boxboard. Specially designed for storage of small collectors' items (animals, dissected insects, jewels, minerals, shells, small archaeological findings etc.). Made from 1600 micron Premier Duo™ Grey/White heavyweight boxboard. Metal-edge construction with the exception of the lid, supplied ready-assembled.

The Master Unit 3D box contains small boxes without lids made in 600 micron Premier Duo™ Grey/White heavyweight boxboard. Comprising 8 small boxes: 4 boxes size 7.5 x 9.5 x 5cm, 2 boxes size 10 x 16 x 5cm and 2 boxes size 15.5 x 20.5 x 5cm. Each box can be fitted with a 5mm padded bottom (optional).



Product code	Internal size mm L x W x H	Internal size inches L x W x H
BXPWBK3040	330 x 420 x 55	12 ⁵ / ₆₄ x 16 ¹ / ₃₂ x 2 ¹¹ / ₆₄

STYLE CODE FB03

Premier Duo™ SP Metal-Edge Window Box

A box designed specifically for natural science-related collections. These boxes have a transparent lid made of 700 micron polyester. On request they can be lined on the inside with a 5mm thick padding made of white polyester felt or of black or white Plastazote® foam. This will offer the objects greater protection. Boxes made from 1300 micron Premier Duo™ Grey/White heavyweight boxboard. Metal-edge construction, supplied ready-assembled.

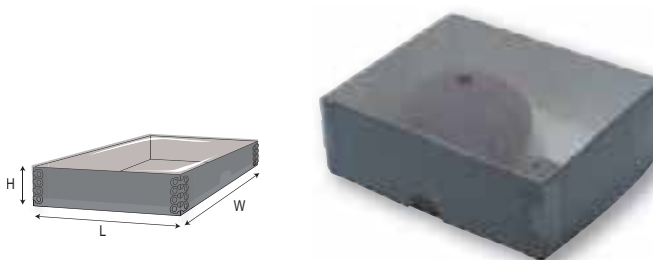

Product code	Internal size mm L x W x H	Internal size inches L x W x H
BXPWSP1531	155 x 310 x 55	6 ¹ / ₆₄ x 12 ¹⁹ / ₆₄ x 2 ¹¹ / ₆₄
BXPWSP1215	125 x 155 x 55	4 ⁹ / ₆₄ x 6 ¹ / ₆₄ x 2 ¹¹ / ₆₄
BXPWSP1525	155 x 255 x 55	6 ¹ / ₆₄ x 10 ¹ / ₆₄ x 2 ¹¹ / ₆₄
BXPWSP2531	250 x 310 x 55	9 ² / ₃₂ x 12 ¹⁹ / ₆₄ x 2 ¹¹ / ₆₄

STYLE CODE FB04

Premier Duo™ STF Metal-Edge Window Box

Two-part box with a separate window shallow-depth lid. The window is made of transparent 100 micron polyester film which allows you to see through to the objects in the box. This box is especially suitable for collections covering areas relating to the natural sciences. The STF box can be lined with Plastazote® or Feutrex™ on request. Made from 1300 micron Premier Duo™ Grey/White heavyweight boxboard. Metal-edge construction, supplied ready-assembled.

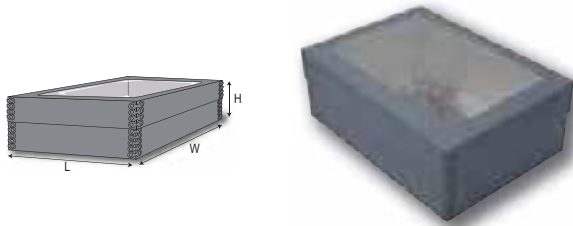

Product code	Internal size mm L x W x H	Internal size inches L x W x H
BXPWBX2430	260 x 320 x 80	10 ¹⁵ / ₆₄ x 12 ¹⁹ / ₃₂ x 3 ⁵ / ₃₂
BXPWBX3040	320 x 420 x 55	12 ¹⁹ / ₃₂ x 16 ¹⁷ / ₃₂ x 2 ¹¹ / ₆₄
BXPWBX2535	240 x 340 x 125	9 ²⁹ / ₆₄ x 13 ²⁵ / ₆₄ x 4 ⁵⁹ / ₆₄
BXPWBX3535	340 x 340 x 125	13 ²⁵ / ₆₄ x 13 ²⁵ / ₆₄ x 4 ⁵⁹ / ₆₄

STYLE CODE FB05

Premier Duo™ MH Metal-Edge Window Box

Hinged-lid box with metal-edge construction. With a 100 x 90mm window in 100 micron polyester in the front of the box allowing the contents stored to be visible without opening the box. Made from 1000 micron Premier Duo™ Grey/White heavyweight boxboard. Suitable for storing historic objects in areas relating to the natural sciences. The MH box can be lined with Plastazote® or Feutrex™ on request. Metal-edge construction, supplied ready-assembled.

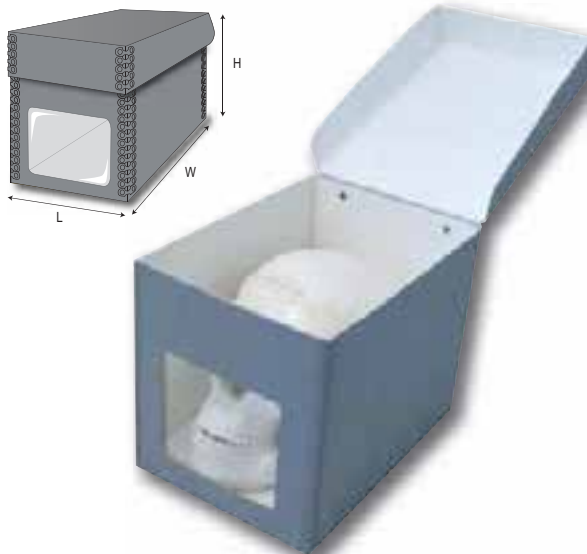

Product code	Internal size mm L x W x H	Internal size inches L x W x H
BXPHLW2216	160 x 230 x 180	6 ¹⁹ / ₆₄ x 9 ¹ / ₁₆ x 7 ¹ / ₃₂

Drawer Tray Boxes

STYLE CODE GB01

EcopHant™ Skull Box with Tray and Lid

Extremely strong and rigid, three-part, die-cut box, tray and lid made from EcopHant™ recycled acid-free boxboard. This style of box is designed to enable viewing the artefact by lifting the lid and/or studying/checking without touching the object by pulling out the tray like a drawer.

Specifications

- Made from EcopHant™ Recycled, Acid-free Boxboard, 100% Recycled
- 100% Chemically Purified Wood-free Fibre
- pH7 to 7.5
- Acid-free and lignin-free
- OBA-free
- Supplied flat-packed
- Colour: Elephant Green
- Also available in Premier Duo™ Archival Boxboard – price on application



Applications

- Suitable for archival storage of items such as a skull

Linked Products: Tissue Paper p93, p99-100; Gloves p215.



Product code	Description	Colour	Thickness micron	Size mm	Size inches	RA/FP
BXTPTB6535	EcopHant™ Box and Lid	Green	1100	147 x 214 x 164	5 ¹³ / ₁₆ x 8 ⁷ / ₁₆ x 6 ⁷ / ₁₆	FP
BXTPTB6602	EcopHant™ Box and Lid	Green	1100	145 x 335 x 166	5 ¹¹ / ₁₆ x 13 ¹³ / ₁₆ x 6 ⁶ / ₁₆	FP
BXTPTB8461	EcopHant™ Box and Lid	Green	1100	193 x 223 x 165	7 ⁹ / ₃₂ x 8 ²⁵ / ₃₂ x 6 ¹ / ₂	FP
BXTPTB8509	EcopHant™ Box and Lid	Green	1300	150 x 150 x 200	5 ²⁹ / ₃₂ x 5 ²⁹ / ₃₂ x 7 ⁷ / ₈	FP
BXTPTB8510	EcopHant™ Box and Lid	Green	1300	200 x 150 x 250	7 ⁷ / ₈ x 5 ²⁹ / ₃₂ x 9 ²⁷ / ₃₂	FP
BXTPTB8511	EcopHant™ Box and Lid	Green	1300	200 x 250 x 300	7 ⁷ / ₈ x 9 ²⁷ / ₃₂ x 11 ¹³ / ₁₆	FP

Storage Trays

STYLE CODE HB01

Storage Trays

Simple tray, made from single and double wall Premier Duo™ Archival Folding Boxboard, EcopHant™ Board or Heritage Archival pHotokraft™ (HAPK) ideal for artefacts or specimens.

Applications

- Suitable for archival storage, natural history collections, museum collections within drawers and cabinets

Linked Products: Envelopes p42; Tissue Paper p93, p99-100; Gloves p215.



Product code	Description	Material	Colour	Thickness micron	Size mm	Size inches	RA/FP
BXTRAY6170	Double wall	HAPK	White	500	102 x 77 x 40	4 x 3 ¹ / ₁₆ x 1 ¹ / ₁₆	FP
BXTRAY6050	Double wall	HAPK	White	350	70 x 50 x 30	2 ³ / ₄ x 1 ⁹ / ₁₆ x 1 ³ / ₁₆	FP
BXTRAY6470	Double wall	Premier Duo™	Grey/White	1000	224 x 275 x 112	8 ⁹ / ₁₆ x 10 ¹³ / ₁₆ x 4 ¹ / ₁₆	RA
BXTRAY6774	Wire stitched	EcopHant™	Elephant Green	1300	454 x 217 x 68	17 ⁷ / ₈ x 8 ⁵ / ₁₆ x 2 ¹¹ / ₁₆	RA

STYLE CODE HB02

Premier Duo™ MICROBOX

A single drawer-type box, designed to hold 8 BXPTMB1973 or BXPTMB4359 Microboxes. Made from 1300 micron Premier Duo™ Grey/White heavyweight boxboard. Tabbed design for easy assembly. Supplied flat-packed.

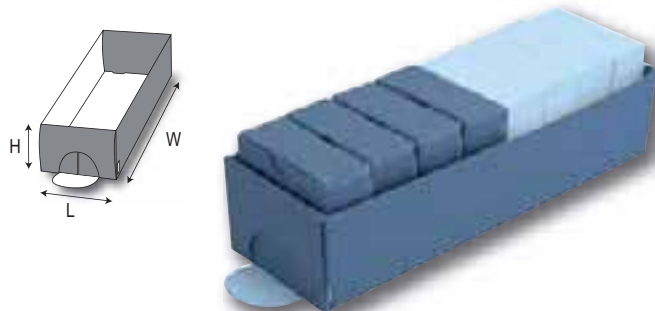

Product code	Internal size mm L x W x H	Internal size inches L x W x H
BXTRAY1134	110 x 340 x 80	4 ¹ / ₁₆ x 13 ⁵ / ₁₆ x 3 ¹ / ₂

Open-Top Vertical Storage

STYLE CODE IB01

Premier Duo™ Magazine/Pamphlet Boxes

Manufactured from Premier Duo™ Archival acid-free and lignin-free boxboard, this one-piece box has a cut-away top edge for access to vertically stored pamphlets, magazines or documents – allowing permanent visibility. Die-cut and secured using tabs and slots without the need for wire-stitching or gluing.

Premier Duo™ Magazine/Pamphlet boxes are supplied flat-packed for easy, low-cost shipping and space-saving. Self-assemble when ready to use.

Specifications

- Made from Premier Duo™ Archival Folding Boxboard
- Supplied flat-packed
- Colour: Grey/White as standard
- Duke Parchment/White colour available for special order

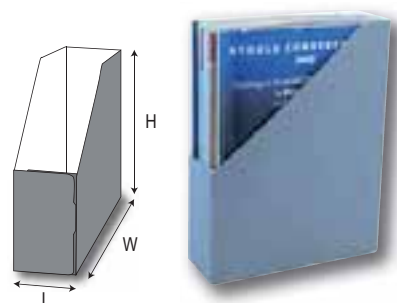

Product code	Internal size mm	Internal size inches
BXPSPB6169	70 x 222 x 240	2 ³ / ₄ x 8 ³ / ₁₆ x 9
BXPSPB2230	80 x 230 x 300	3 ¹ / ₂ x 9 ¹ / ₁₆ x 11 ¹ / ₁₆
BXPSPB2402	80 x 224 x 322	3 ¹ / ₂ x 8 ⁹ / ₁₆ x 12 ⁵ / ₁₆

STYLE CODE IB02

Premier Duo™ Open-Top File Box

This one-piece, open-top box has been designed for easy access to working files. They can also be used in filing cabinets. They are embossed to position labels and are supplied flat for self-assembly.

Specifications

- Made from Premier Duo™ Archival Folding Boxboard
- Supplied flat-packed
- Colour: Grey/White as standard
- Duke Parchment/White colour available for special order



Applications

- Suitable for archival storage of books, documents, photographs, prints

Linked Products: Document Boxes p23 and 26; Envelopes p42; Folders p42; Timecare™ Carry Cube p32.

BXGWPB8064 Flat-packed

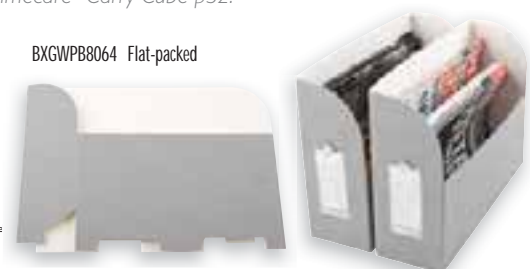

Product code	Description	Colour	Thickness micron	Size mm	Size inches	RA/FP
BXGWPB8064	Foolscap Folio	Grey/White	1300	350 x 313 x 100	13 ³ / ₄ x 12 ³ / ₁₆ x 3 ¹ / ₁₆	FP

Premier Duo™ SL Metal-Edge Book End Box

A book end box designed for storing and keeping books on racks and shelves. Open box made from 1600 micron Premier Duo™ Grey/White heavyweight boxboard, ensuring excellent accessibility to books. Metal-edge construction, supplied ready-assembled.

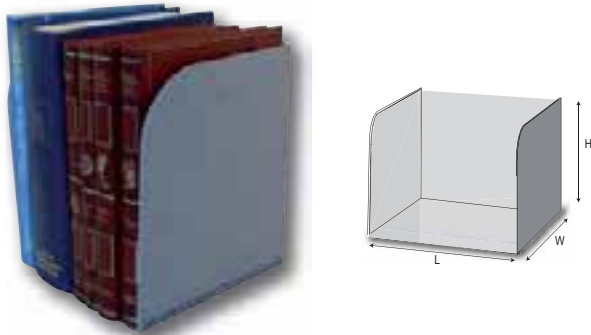

Product code	Internal size mm L x W x H	Internal size inches L x W x H
BXSHOE2019	225 x 200 x 195	8 ⁵ / ₁₆ x 7 ⁷ / ₈ x 7 ⁹ / ₁₆
BXSHOE2326	225 x 230 x 265	8 ⁵ / ₁₆ x 9 ¹ / ₁₆ x 10 ¹ / ₁₆



Tube Boxes

STYLE CODE JB01

Premier Duo™ Cube Tubes™ Telescopic and non-telescopic

Easy stacking telescopic and non-telescopic Cube Tubes™, made from Premier Duo™ Archival acid-free and lignin-free boxboard. The boxes are supplied flat-packed for easy, low-cost shipping and space-saving until ready to use. The telescopic design offers the flexibility to store rolls of varying length. When constructed these boxes make it easier to extract items than conventional round tubes, thereby making it a safer form of storage for the object. They feature hinged tops that cannot get lost and yet allow access without removal from the stack/shelf. They can also be stacked more easily into neat blocks.

Linked Products: Map Bags p78; Tissue Paper p93, p99-100; Cotton Tying Tape p135.

Specifications

- Made from Premier Duo™ Archival Folding Boxboard
- Supplied flat-packed
- Colour: Grey/White as standard
Duke Parchment/White on request



Applications

- Suitable for archival storage of maps, plans, prints, drawings and textiles



MODULAR SIZES

One large Cube Tube™ can stack with four small

Product code	Description	Colour	Thickness micron	Internal size mm	Internal size inches	RA/FP
BXCTTT3375	Telescopic to approx 1500mm	Grey/White	1300	100 x 100 x 800	3 ¹⁵ / ₁₆ x 3 ¹⁵ / ₁₆ x 31 ¹ / ₂	FP
BXCTTT3376	Telescopic to approx 2050mm	Grey/White	1300	100 x 100 x 1150	3 ¹⁵ / ₁₆ x 3 ¹⁵ / ₁₆ x 45 ¹ / ₄	FP
BXCTTT3797	Telescopic to approx 1500mm	Grey/White	1300	195 x 175 x 800	7 ¹¹ / ₁₆ x 6 ⁷ / ₈ x 31 ¹ / ₂	FP
BXCTTH3797	As above but with handle	Grey/White	1300	195 x 175 x 800	7 ¹¹ / ₁₆ x 6 ⁷ / ₈ x 31 ¹ / ₂	FP
BXCTTT5143	Telescopic to approx 1500mm	Grey/White	1300	120 x 120 x 800	4 ³ / ₄ x 4 ³ / ₄ x 31 ¹ / ₂	FP
BXCTTT3923	Telescopic to approx 1500mm	Grey/White	1300	150 x 150 x 800	5 ⁷ / ₈ x 5 ⁷ / ₈ x 31 ¹ / ₂	FP
BXCTTT3455	Telescopic to approx 1500mm	Grey/White	1300	200 x 200 x 800	7 ⁷ / ₈ x 7 ⁷ / ₈ x 31 ¹ / ₂	FP
BXCTNT3734	Non Telescopic	Grey/White	1300	50 x 50 x 1150	1 ¹⁵ / ₁₆ x 1 ¹⁵ / ₁₆ x 45 ¹ / ₄	FP
BXCTNT3735	Non Telescopic	Grey/White	1300	100 x 100 x 1150	3 ¹⁵ / ₁₆ x 3 ¹⁵ / ₁₆ x 45 ¹ / ₄	FP
BXCTNT6074	Non Telescopic	Grey/White	1000	80 x 80 x 800	3 ¹ / ₈ x 3 ¹ / ₈ x 31 ¹ / ₂	FP
BXCTNT6178	Non Telescopic	Grey/White	1300	100 x 100 x 800	3 ¹⁵ / ₁₆ x 3 ¹⁵ / ₁₆ x 31 ¹ / ₂	FP
BXCTNT6385	Non Telescopic	Grey/White	1000	100 x 100 x 800	3 ¹⁵ / ₁₆ x 3 ¹⁵ / ₁₆ x 31 ¹ / ₂	FP
BXPDFT1215	Non Telescopic	Grey/White	1000	150 x 150 x 1200	5 ⁹ / ₁₆ x 5 ⁹ / ₁₆ x 47 ¹ / ₄	FP
BXPDFT0656	Non Telescopic	Grey/White	1000	60 x 60 x 650	2 ² / ₁₆ x 2 ² / ₁₆ x 25 ¹ / ₁₆	FP
BXCTNT8498	Non Telescopic	Grey/White	1000	583 x 78 x 78	22 ³ / ₁₆ x 3 ³ / ₁₆ x 3 ³ / ₁₆	FP
BXCTNT6936	Non Telescopic	Grey/White	1300	960 x 120 x 120	37 ³ / ₁₆ x 4 ³ / ₁₆ x 4 ³ / ₁₆	FP

STYLE CODE JB02

Premier Duo™ Metal-Edge Tube Box

This box with separate lid is suitable for the storage of rolled-up documents such as plans, maps and posters. Supplied with two semi-circular Plastazote® plinth rests and cylindrical tube. Made of 1600 micron Premier Duo™ Grey/White heavyweight boxboard, metal-edge construction, supplied ready-assembled.

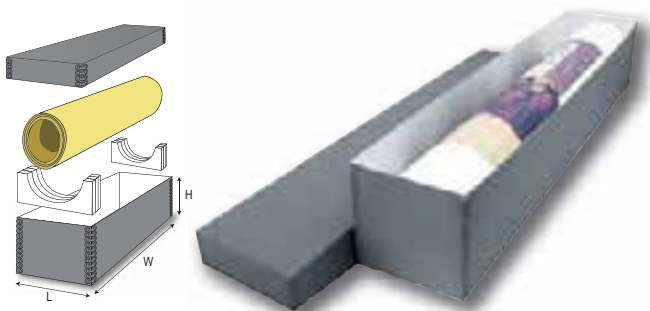

Product code	Internal size mm L x W x H	Internal size inches L x W x H
BXPTPS8015	150 x 800 x 150	5 ⁹ / ₃₂ x 31 ¹ / ₂ x 5 ⁹ / ₃₂
BXPTPS1415	150 x 1140 x 150	5 ⁹ / ₃₂ x 44 ⁷ / ₈ x 5 ⁹ / ₃₂
BXPTPS3015	150 x 1300 x 150	5 ⁹ / ₃₂ x 51 ¹ / ₁₆ x 5 ⁹ / ₃₂
BXPTPM8015*	150 x 800 x 150	5 ⁹ / ₃₂ x 31 ¹ / ₂ x 5 ⁹ / ₃₂
BXPTPM1415*	150 x 1140 x 150	5 ⁹ / ₃₂ x 44 ⁷ / ₈ x 5 ⁹ / ₃₂
BXPTPM3015*	150 x 1300 x 150	5 ⁹ / ₃₂ x 51 ¹ / ₁₆ x 5 ⁹ / ₃₂

*without cube

STYLE CODE JB03

PolypHlute™ Roll Box



The boxes are made from our PolypHlute™ Fluted Polypropylene grey board. Opening on one long side with a hinged lid. For the storage of plans or other rolled-up documents and textiles. Tabbed construction, supplied flat-packed.

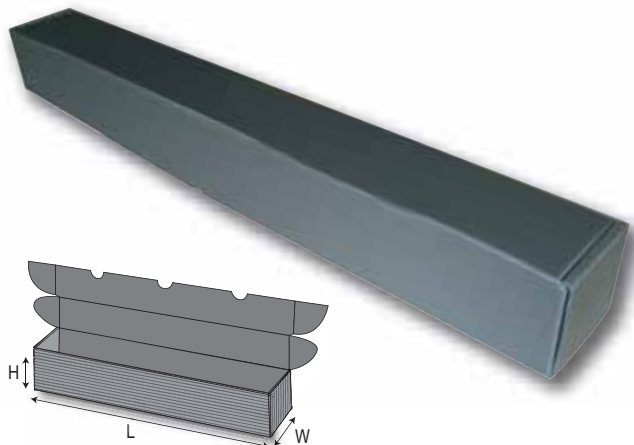

Product code	Internal size mm L x W x H	Internal size inches L x W x H
BXPCTH0200	2000 x 150 x 150	78 ⁴ / ₆₄ x 5 ⁹ / ₃₂ x 5 ⁹ / ₃₂
BXPCTH0130	1300 x 150 x 150	51 ¹ / ₁₆ x 5 ⁹ / ₃₂ x 5 ⁹ / ₃₂
BXPCTH0100	1000 x 130 x 130	39 ³ / ₈ x 5 ¹ / ₈ x 5 ¹ / ₈
BXPCTH0070	700 x 130 x 130	27 ¹ / ₁₆ x 5 ¹ / ₈ x 5 ¹ / ₈

STYLE CODE JB04

Chartpak Roll Storage

Inert polypropylene plastic tubes for the storage of maps, plans and materials housed in roll form. The static-free polypropylene units with end-pieces in place are dust and waterproof and the easy grip aids handling. The unique Chartpak design prevents discolouration or fade-damage from UV tubes. Available in two diameters and can be lengthened by using additional spacer pieces to extend the tube length as required. Should the tube be too long, simply remove a spacer until you have the correct length. Independent tests have established that the Chartpak system has a neutral range pH and does not contain any additives that might migrate at any point in the future.

Specifications

- Inert polypropylene
- Supplied ready-assembled
- Neutral pH
- UV protection
- Static-free polypropylene units
- Available in two diameters
- Additional spacer pieces
- Colour: Grey

Applications

Suitable for storage of maps, plans and materials housed in roll form

When ordering:

Decide how many spacers, bottom and top caps you require. Prices vary according to the total amount taken. Sizes can be mixed to benefit price breaks.



Product code	Description	Colour	Internal size mm	Internal size inches	RA/FP
BXCPC0002	Spacer	Grey	305 x 75 ∅	12 x 2 ⁹ / ₆₄ ∅	RA
BXCPC0003	Bottom Cap	Grey	565 x 75 ∅	22 ¹ / ₄ x 2 ⁹ / ₆₄ ∅	RA
BXCPLC0001	Top Cap	Grey	108 x 100 ∅	4 ¹ / ₄ x 3 ⁵ / ₁₆ ∅	RA
BXCPLC0002	Spacer	Grey	305 x 100 ∅	12 x 3 ⁵ / ₁₆ ∅	RA
BXCPLC0003	Bottom Cap	Grey	568 x 100 ∅	22 ³ / ₈ x 3 ⁵ / ₁₆ ∅	RA

∅ = Diameter

STYLE CODE JB05

Premier Rollsafe™ Storage Tubes

Made from Heritage Archival pHotokraft™ paper and laminated with Evacon-R™ adhesive to produce a tube of the highest conservation quality. This bespoke product is available on application.

Custom-made Premier Rollsafe™ Tube Service

Plastic end-plugs are also available for the most common internal tube diameters including:

5mm (2")	76mm (3")	101mm (4")
152mm (6")	200mm (8")	254mm (10")

All Premier Rollsafe™ tubes are made to order. Please allow time for manufacturing.

Specifications

- Acid-free, lignin-free and passes the PAT Photographic Activity Test
- Available in White or Grey



Applications

Suitable for storage of maps, plans and materials housed in roll form

Linked Products: Tissue Paper p93, p99-100; Map Bag p78; Gloves p215.

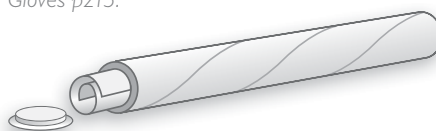

Folders, Envelopes and Pockets

The Conservation By Design (CXD) folders, envelopes and pockets range is designed for the storage and preservation of a wide variety of archival material including photographs. They can be made from any of the papers and boards featured in this catalogue depending on the storage and performance needs of the object and the archivist.

Mostly they are made from paper and board but we do include some plastic-based products with unique performance characteristics such as PolypHlute™ fluted Polypropylene, Corrosion Intercept® pollution scavenger films or the Visifile™ transparent polypropylene drawer folders.

There are three types of paper and board from which the folders and envelopes are made.



Premier™ Heritage Archival pHotokraft™ Paper

The Premier Duo™ range of folders and envelopes are based on Heritage Archival pHotokraft™ paper, which is designed for strength and purity. It is available in a variety of popular lightfast colours; Neutral Grey, Taupe, Duke Parchment, Old Grey Ivory and White. The paper is acid and lignin-free, passes the Photographic Activity Test (PAT) and is made from long-fibred, archival-quality 'Kraft' fibres. The White colour is available buffered or unbuffered for storing special types of photographs.

Premier™ Heritage Archival pHotokraft™ range



Premier Duo™ Laminated Paper and Board

Premier Duo™ folders and envelopes are produced by laminating two different colours of Heritage Archival pHotokraft™ paper together. Lamination gives an attractive appearance while imparting extra fold and tear strength. The standard Duplex colours are Neutral Grey and White and are available in 300 micron, 650 micron, 1000 micron, 1300 micron and 1625 micron callipers.

pHoton™ 100% Cotton High-Purity Paper

pHoton™ is a high-purity paper made from 100% pure cotton fibre to a fixed quality standard by the Munktel Mill which is famous for producing the world's first chromatography filter paper. The mill mainly produces scientific and medical grades and is therefore ideal for the production of photographic storage paper which requires the highest level of consistent purity. In this section there are a variety of folders and envelopes designed for photographic storage.

A full specification for the pHoton™ paper can be found in the Papers, Materials and Boards section.

We are happy to produce special custom sizes and designs in any quantity using our Kasemake CXD made-to-measure Smart™ service.

Style Codes: how to use the style code system

In this section the product range has been categorised using 'style codes'. These have been developed to assist customers with locating a particular style of Box, Folder, Envelope or Pocket.

These style codes are also of assistance when ordering custom-made Boxes, Folders, Envelopes or Pockets using our 'Smart' computer-generated service.

Just quote the 'style code', provide your desired measurements and quantity to receive a quotation for your approval.



SMART SERVICE
custom-made boxes
available for this product

Folders, Envelopes and Pockets Styles

Style Code

Single and Double-Crease Folders

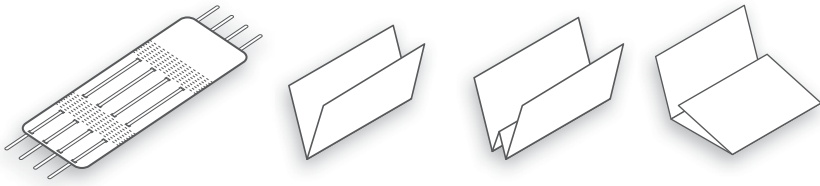

AF – p.44

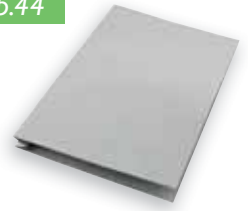

L-Shaped Folders

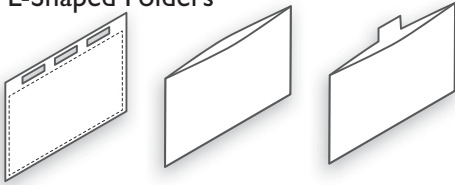

BF – p.47



Open Topless Wallets/Pockets/Enclosures

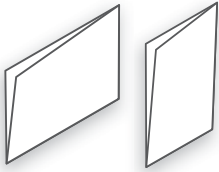

CF – p.48



Envelopes/Wallets/Pockets with Flap



DF – p.52



Pocket Envelopes with Non-Adhesive Flap



EF – p.54



Open-Top Expansion Wallets/Pockets Adhesive Flap

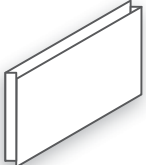

FF – p.62



Gusseted Expansion Wallets

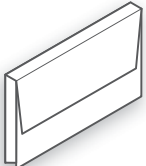

GF – p.54



Four-Flap Folders

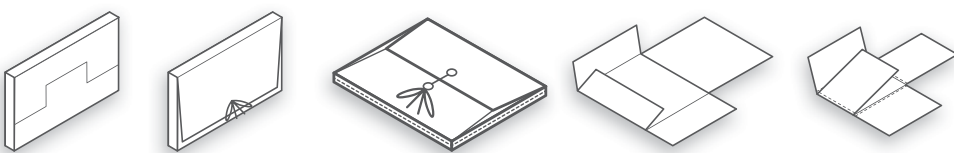

HF – p.55



pHoton™ High-Purity Photographic Storage

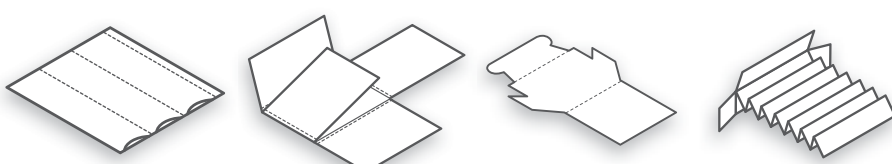

CF, DF & HF – p.63-66



Single and Double-Crease Folders

STYLE CODE AF01

Premier™ and Premier Duo™ Single-Crease Folder

Made from Premier Duo™ Grey/White or Heritage Archival pHotokraft™ paper, these single-crease folders are suitable for holding loose papers, prints, drawings and photographs etc.

Some single-crease folders are designed to fit the Drop-Spine 'P-Box' system. We are able to quote for a box to accommodate any size folder. Also available in 90gsm.

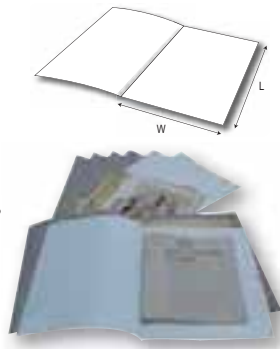

Linked Products: P-Boxes p12 and p74.



Single-Crease Folder

Product code	Description	Colour	Weight	Size mm L x W	Size inches L x W	Pack qty
FDPSCF1350	Single-Crease Folder	Grey/White	300mic	381 x 280	15 x 11 ¹ / ₂	100
FDPSCF3435	Single-Crease Folder	Grey/White	300mic	270 x 205	10 ⁵ / ₈ x 8 ¹ / ₄	100
FDPSCF3436	Single-Crease Folder	Grey/White	300mic	340 x 220	13 ³ / ₆₄ x 8 ² / ₃₂	50
FDPSCF3892	Single-Crease Folder	Grey/White	300mic	570 x 470	22 ¹ / ₁₆ x 18 ¹ / ₂	100
FDPSCF3893	Single-Crease Folder	Grey/White	300mic	470 x 285	18 ¹ / ₂ x 11 ¹ / ₂	100
FDPSCF4028	Single-Crease Folder – Beaux Arts – Royal	Grey	120gsm	600 x 400	23 ³ / ₈ x 15 ¹ / ₄	100
FDPSCF4029	Single-Crease Folder – Beaux Arts – Imperial	Grey	120gsm	800 x 600	31 ¹ / ₂ x 23 ³ / ₈	100
FDPSCF4036	Single-Crease Folder	Grey/White	300mic	369 x 290	14 ¹ / ₃₂ x 11 ² / ₆₄	50
FDPSCF4037	Single-Crease Folder	Grey/White	300mic	420 x 315	16 ¹ / ₃₂ x 12 ¹ / ₃₂	50
FDPSCF4999	Single-Crease Folder	Grey	350gsm	890 x 660	35 ³ / ₆₄ x 25 ⁶ / ₆₄	100
FDPSCF5048	Single-Crease Folder	Grey/White	300mic	508 x 406	20 x 15 ⁶ / ₆₄	100
FDPSCF5100	Single-Crease Folder – 2 binder holes, 80mm centres	Grey	120gsm	330 x 242	12 ⁶ / ₆₄ x 9 ¹ / ₃₂	100
FDPSCF6068	Single-Crease Folder	White	120gsm	449 x 287	17 ⁴ / ₆₄ x 11 ¹ / ₆₄	100
FDPSCF6137	Single-Crease Folder – 1 crease of 15mm at centre fold	Duke	350gsm	535 x 333	21 ¹ / ₁₆ x 13 ¹ / ₆₄	100
FDPSCF6138	Single-Crease Folder – 1 crease of 27mm at centre fold	Duke	350gsm	535 x 333	21 ¹ / ₁₆ x 13 ¹ / ₆₄	100
FDPSCF6140	Single-Crease Folder – 2 x5mm creases at centre fold, one side	Grey	230gsm	350 x 268	13 ² / ₃₂ x 10 ³ / ₆₄	100
FDPSCF6141	Single-Crease Folder	Grey	120gsm	285 x 225	11 ¹ / ₃₂ x 8 ⁵ / ₆₄	100
FDPSCF6146	Single-Crease Folder	Grey	120gsm	355 x 235	13 ¹ / ₃₂ x 9 ¹ / ₄	50
FDPSCF6148	Single-Crease Folder – 2 x5mm creases at centre fold, one side	Grey	230gsm	350 x 252	13 ² / ₃₂ x 9 ⁹ / ₆₄	100
FDPSCF6231	Single-Crease Folder - Landscape	Grey	350gsm	193 x 250	7 ⁹ / ₃₂ x 9 ² / ₃₂	100
FDPSCF6237	Single-Crease Folder	Grey/White	300mic	400 x 300	15 ¹ / ₄ x 11 ¹ / ₁₆	100
FDPSCF6243	Single-Crease Folder - 2x 15mm creases at centre fold, one side	Grey/White	300mic	400 x 300	15 ¹ / ₄ x 11 ¹ / ₁₆	100
FDPSCF6328	Single-Crease Folder	Grey	350gsm	823 x 560	32 ¹ / ₃₂ x 22 ¹ / ₆₄	100
FDPSCF6334	Single-Crease Folder	Grey/White	300mic	188 x 140	7 ¹ / ₃₂ x 5 ³ / ₆₄	100
FDPSCF6335	Single-Crease Folder	Grey/White	300mic	257 x 194	10 ¹ / ₈ x 7 ¹ / ₆₄	100
FDPSCF6336	Single-Crease Folder	Grey/White	300mic	270 x 213	10 ⁵ / ₈ x 8 ² / ₆₄	100
FDPSCF6339	Single-Crease Folder	Grey/White	300mic	418 x 315	16 ² / ₆₄ x 12 ¹ / ₃₂	50
FDPSCF6340	Single-Crease Folder	Grey/White	300mic	518 x 417	20 ² / ₆₄ x 16 ² / ₆₄	100
FDPSCF6016	Premier Single-Crease Folder	White	120gsm	262 x 208	10 ¹ / ₁₆ x 8 ³ / ₁₆	
FDPSCF6015	Premier Square Cut Single-Crease Folder	White	120gsm	325 x 252	12 ² / ₆₄ x 9 ⁹ / ₆₄	
FDPSCF6060	Premier Single-Crease Folder	White	120gsm	580 x 405	22 ² / ₆₄ x 15 ¹ / ₁₆	
FDPSCF6018	Premier Square Cut Single-Crease Folder	Ivory	170gsm	545 x 430	21 ² / ₆₄ x 16 ³ / ₆₄	

Single-Crease Folder continued.

Product code	Description	Colour	Weight gsm	Size mm L x W	Size inches	Pack qty
FDPSCF6346	Single-Crease Folder	Grey	120	365 x 260	14 ³ / ₈ x 10 ³ / ₆₄	50
FDPSCF6572	Single-Crease Folder	Grey/White	300mic	420 x 280	16 ¹ / ₃₂ x 11 ¹ / ₃₂	100
FDPSCF6615	Single-Crease Folder	Grey/White	300mic	370 x 230	14 ¹ / ₁₆ x 9 ¹ / ₁₆	100
FDPSCF6620	Single-Crease Folder	White	230	380 x 295	14 ⁶ / ₆₄ x 11 ³ / ₆₄	100
FDPSCF6621	Single-Crease Folder	Grey/White	300mic	380 x 295	14 ⁶ / ₆₄ x 11 ³ / ₆₄	100
FDPSCF7105	Single-Crease Folder	White	120	533 x 333	20 ⁶ / ₆₄ x 13 ¹ / ₆₄	100
FDPSCF4035	Single-Crease Folder	Grey/White	300mic	318 x 263	12 ³ / ₆₄ x 10 ³ / ₆₄	50
FDPSCF6337	Single-Crease Folder	Grey/White	300mic	318 x 263	12 ³ / ₆₄ x 10 ³ / ₆₄	100
FDPSCF6341	Single-Crease Folder	Grey	350	622 x 519	24 ³ / ₆₄ x 20 ¹ / ₁₆	100
FDPSCF6753	Single-Crease Folder	Cream	80	250 x 200	9 ² / ₃₂ x 7 ¹ / ₈	100
FDASCF6070	Single-Crease Folder	White	120	498 x 338	19 ³ / ₆₄ x 13 ¹ / ₁₆	
FDASCF6071	Single-Crease Folder	White	120	676 x 496	26 ³ / ₆₄ x 19 ¹ / ₃₂	

Single-Crease Folder for P-Boxes

Product code	Description	Weight gsm	Colour	Size mm L x W	Size inches L x W	Pack qty
FDPSCF6334	Single-Crease Folder	300mic	Grey/White	188 x 140	7 ¹ / ₃₂ x 5 ³ / ₆₄	100
FDPSCF6335	Single-Crease Folder	300mic	Grey/White	257 x 194	10 ¹ / ₈ x 7 ¹ / ₆₄	100
FDPSCF6336	Single-Crease Folder	300mic	Grey/White	270 x 213	10 ⁵ / ₈ x 8 ² / ₆₄	100
FDPSCF6337	Single-Crease Folder	300mic	Grey/White	318 x 263	12 ³ / ₆₄ x 10 ³ / ₆₄	100
FDPSCF4036	Single-Crease Folder	300mic	Grey/White	369 x 290	14 ¹ / ₃₂ x 11 ² / ₆₄	50
FDPSCF6339	Single-Crease Folder	300mic	Grey/White	418 x 315	16 ² / ₆₄ x 12 ¹ / ₃₂	50
FDPSCF6340	Single-Crease Folder	300mic	Grey/White	518 x 417	20 ² / ₆₄ x 16 ² / ₆₄	100
FDPSCF6341	Single-Crease Folder	350	Grey	622 x 519	24 ³ / ₆₄ x 20 ¹ / ₁₆	100

Stouls Single-Crease Folder

Product code	Weight gsm	Colour	Size mm L x W	Size inches L x W	Pack qty
FDPSCF1703	170	White	340 x 250	13 ² / ₆₄ x 9 ² / ₃₂	50
FDPSCF9005	90	White	410 x 310	16 ¹ / ₆₄ x 12 ¹ / ₆₄	100
FDPSCF1201	120	White	310 x 220	12 ¹ / ₆₄ x 8 ² / ₃₂	100
FDPSCF9002	90	White	320 x 240	12 ¹ / ₃₂ x 9 ² / ₆₄	100
FDPSCF9001	90	White	310 x 220	12 ¹ / ₆₄ x 8 ² / ₃₂	100
FDPSCF1202	120	White	300 x 240	11 ¹ / ₁₆ x 9 ² / ₆₄	100
FDPSCF1203	120	White	410 x 310	16 ¹ / ₆₄ x 12 ¹ / ₆₄	50
FDPSCF9004	90	White	430 x 310	16 ³ / ₆₄ x 12 ¹ / ₆₄	50
FDPSCF1204	120	White	510 x 410	20 ¹ / ₆₄ x 16 ¹ / ₆₄	50
FDPSCF1705	170	White	610 x 510	24 ¹ / ₆₄ x 20 ¹ / ₆₄	25
FDPSCF1706	170	White	660 x 510	25 ³ / ₆₄ x 20 ¹ / ₆₄	25
FDPSCF1701	170	Taupe	430 x 310	16 ³ / ₆₄ x 12 ¹ / ₆₄	25
FDPSCF1702	170	Taupe	320 x 240	12 ¹ / ₃₂ x 9 ² / ₆₄	50
FDPSCF1707	170	White	740 x 530	29 ¹ / ₆₄ x 20 ³ / ₆₄	25
FDPSCF1704	170	White	540 x 415	21 ¹ / ₆₄ x 16 ¹ / ₃₂	25

Specifications

- Acid-free
- Lignin-free
- OBA-free
- CXD Heritage Archival pHotokraft™ (HAPK) paper
- Available in White, Taupe, Grey/White Duke Parchment



Premier™ and Premier Duo™ P-Box Photographic Mounting and Storage System

See p12 for full information

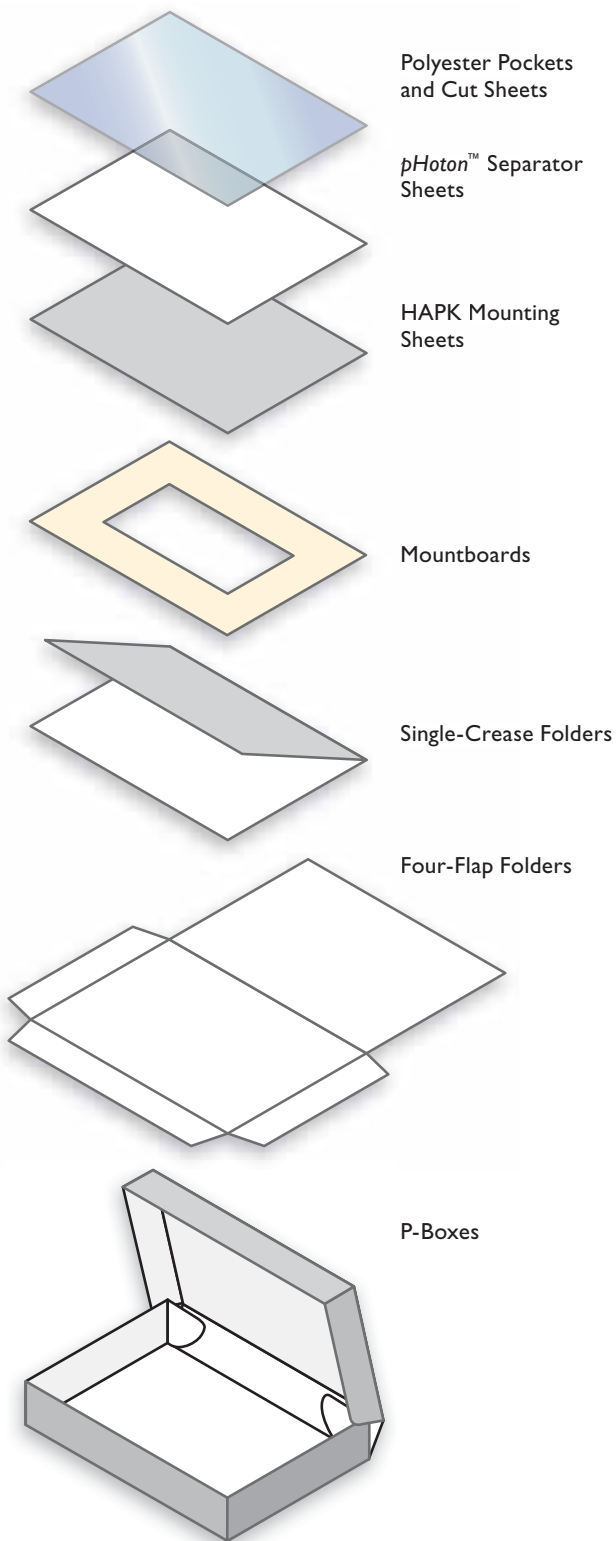

i Information

P-BOX SIZE GUIDE
GLASS PLATE SIZES

P0 = 5" x 7"
PZ = 10" x 7"

PHOTOGRAPHIC PRINT SIZES

P1 = 8" x 10"
P2 = 10" x 12"
P3 = 12" x 16"
PX = 14" x 11"
P4 = 16" x 20"
P5 = 20" x 24" or A2

STYLE CODE AF02

Premier™ and Premier Duo™ Double-Crease Folder

Made from Premier Duo™ Grey/White or Heritage Archival pHotokraft™ (HAPK) Paper, these simple folders are suitable for holding loose papers, prints and drawings etc. in larger amounts than the single-crease design.

Linked Products: Drop-Spine Boxes p11.



Specifications

- Acid-free
- Lignin-free
- OBA-free



Product code	Description	Colour	Weight/Thickness gsm/micron	Size mm	Size inches
FDPDCF6222	Double-Creased	Grey	120gsm	355 x 235 x 50	14 x 9¼ x 1¾
FDPDCF6663	Double-Creased	Grey	120gsm	365 x 260 x 50	14¾ x 10¼ x 1¾
FDPDCF3426	Double-Creased	Grey/White	300mic	340 x 220 x 50	13¾ x 8½ x 1¾
FDPDCF6420	Double-Creased	Grey/White	300mic	375 x 260 x 50	14¾ x 10¼ x 1¾
FDPDCF6710	Multi-Creased	Grey/White	300mic	370 x 230 x 24	14¾ x 9¾ x 0½
FDPDCF6581	Double-Creased	Grey	350gsm	340 x 220 x 50	13¾ x 8½ x 1¾

Heritage Archival pHotokraft™

These folders can also be supplied in any colour or weight from the Heritage Archival pHotokraft™ (HAPK) paper range including White, Duke Parchment, Neutral Grey, Taupe and Old Grey Ivory. White also available unbuffered. Prices on application.

STYLE CODE AF03

Premier™ and Premier Duo™ Triptych Folder

Made from Premier Duo™ Archival Folding Boxboard and Heritage Archival pHotokraft™ Paper, these folders have one full and one small-sized flap that fold inwards.

Linked Products: Cotton Tying Tape p135.

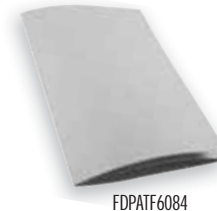

Product code	Description	Colour	Weight gsm	Thickness microns	Size mm	Size inches
FDPSCF6524	Triptych	Old Grey Ivory	170		325 x 252	12¾ x 9½
FDPATF6084	Triptych	Grey	230		385 x 255	15¾ x 10¼
FDPATF4379	Triptych	Grey/White		1000	900 x 630	35¾ x 24¾
FDPATF6490	2 parts glued together	Grey	350		1070 x 735	42¾ x 28¾
FDPATF8162	Premier Triptych Folder	Ivory	230		344 x 239 x 20	13¾ x 9½ x 0¾
FDPATF8291	Premier Triptych Folder	Ivory	230		385 x 255	15¾ x 10¼
FDPATF8316	Premier Triptych Folder	Grey	350		1300 x 860	51¾ x 33¾
FDPATF8399	Premier Triptych Folder	Grey	230		370 x 255	14¾ x 10¼

STYLE CODE AF04

Premier Duo™ Wallpaper Sample Book Wrapper

Premier™ Wallpaper Sample Book Storage Box and Multi-Crease Wrapper is part of a box and folder system originally produced for the storage and protection of wallpaper sample books e.g. Sandersons. Made from CXD Premier Duo™ Archival Folding Boxboard, the wrapper may be ordered separately from the box. For flexible storage and protection this wrapper has multi-creases offering different heights with tape slots to assist in enclosing the volume securely (Cotton Tying Tape not provided). The wrapper is designed to enclose the volume snugly and facilitates lifting it safely out of the storage box. The multi-crease wrapper can form wedge shapes around the volume.

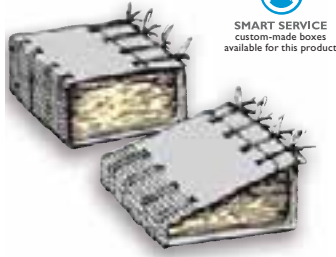

Specifications

- Acid-free
 - Lignin-free
 - OBA-free
 - Made from 1300 micron CXD Premier Duo™ Archival Folding Boxboard
 - Multi-creases
 - Cotton tape tying slots
 - Available in Duplex Neutral Grey/White or Duke Parchment/White
- Prices on application



Linked Products: Cotton Tying Tapes p135; CXD Archival Premier Duo™ and Wallpaper Sample Book Box p35.

Product code	Description	Colour	Thickness microns	Size mm	Size inches
FDMCWR3496	With tape slots	Grey/White	1300	545 x 540 x 176	21 ¹ / ₁₆ x 21 ¹ / ₁₆ x 6 ¹⁵ / ₁₆
FDMCWR4729	With tape slots	Grey/White	1300	540 x 510 x 195	21 ¹ / ₁₆ x 20 ¹ / ₁₆ x 7 ¹ / ₁₆

NB. Cotton Tying Tape not provided

Designed to fit with CXD Archival Premier Duo™ Two-Part Print and Newspaper Box, see page 28.

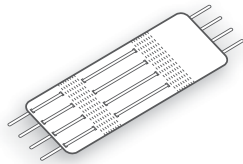

STYLE CODE AF05

Premier™ and Premier Duo™ Folder with Internal Envelope

Single-Crease Folder made from 400gsm Stouls 'Satin' Conservation SolidCore Board. With an inner envelope attached to the inside of the folder, opening on the long side with a full flap, providing excellent protection against dust.

The internal envelope is made from our 120gsm White Heritage Archival pHotokraft™ Paper.

A simple folder allowing you to keep various kinds of documents safe.

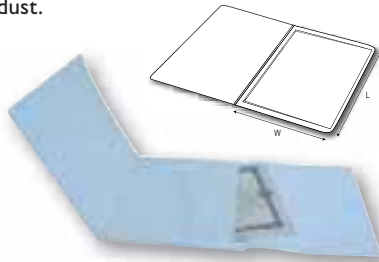

Specifications

- Acid-free
- Lignin-free
- OBA-free
- CXD Heritage Archival pHotokraft™ (HAPK) paper
- Available in White



Product code	Internal size mm L x W	External size mm L x W	Internal size inches L x W	External size inches L x W	Pack qty
FDMWF0001	260 x 195	275 x 205	10 ¹ / ₁₆ x 7 ⁹ / ₁₆	10 ⁹ / ₁₆ x 8 ⁵ / ₁₆	5
FDMWF0002	340 x 255	355 x 265	13 ³ / ₁₆ x 10 ¹ / ₁₆	13 ³ / ₁₆ x 10 ¹ / ₁₆	5
FDMWF0003	410 x 315	425 x 325	16 ¹ / ₁₆ x 12 ¹³ / ₁₆	16 ¹ / ₁₆ x 12 ¹³ / ₁₆	5

STYLE CODE AF06

Premier Duo™ Archival Single-Crease Folder

This Single-Crease Folder is designed for the protection, conservation and storage of large documents in map and plan furniture. It features cotton tape ties on 3 sides for secure closure and safe transportation. Made from our 1000 micron Premier Duo™ Grey /White heavyweight boxboard.

A0 format available on request.

Specifications

- Acid-free
- Lignin-free
- OBA-free
- Premier Duo™ Archival Folding Boxboard
- Available in Neutral Grey/White



Product code	Useful size mm L x W	Useful size inches L x W	Pack qty
FDPSCF8662	820 x 620 x 15	32 ¹ / ₂ x 24 ¹ / ₂ x 1 ¹ / ₂	5

STYLE CODE AF07

Premier Duo™ Expanding Book Wrapper

This wrapper consists of two pieces of multi-creased boxboard which wrap around the item, providing a capacity of up to 70mm. The wrapper is secured with two cotton straps with black polypropylene buckles. Made from 1600 micron Premier Duo™ Grey/White heavyweight boxboard.

This expanding system allows for protection of books, documents, etc. making a strong folder which can be safely stored upright.

Specifications

- Acid-free
- Lignin-free
- OBA-free
- Premier Duo™ Archival Folding Boxboard
- Available in Neutral Grey/White

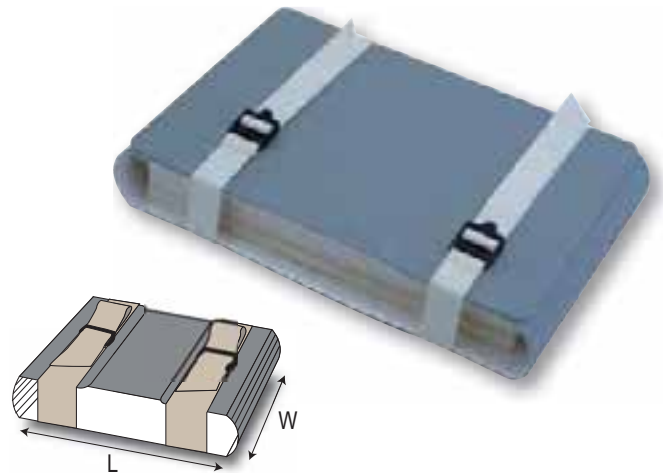

Product code	Useful size mm L x W	Useful size inches L x W	Pack qty
FDMCWR1725	250 x 170	9 ⁷ / ₁₆ x 6 ¹ / ₁₆	5
FDMCWR2332	320 x 230	12 ¹⁹ / ₁₆ x 9 ¹ / ₁₆	5

L-Shaped Folders

STYLE CODE BF01

Premier™ and Premier Duo™ 'L' Wallet Grey

Made from Premier Duo™ Grey/White or CXD Heritage Archival pHotokraft™ (HAPK) Paper these die-cut wallet envelopes are glued on one seam to provide ease of access on the two adjacent sides. Without flap or gusset. Glued with specially formulated Evacon-R™ conservation adhesive. See page 127.

Specifications

- Acid-free
- Lignin-free
- Colours: Old Grey Ivory and Neutral Grey as standard. Also available White, Taupe, Duke Parchment or Duplex Neutral Grey/White, prices on application. White is available in buffered or unbuffered. Unbuffered White is available in 90, 120, 170 and 230gsm.
- The 'L' Wallet can also be made from pHoton™ 100% cotton high-purity papers, prices on application.



STYLE CODE BF02

Premier™ and Premier Duo™ 'L' Wallet White

The style of this wallet offers ease of access on two adjacent sides. Portrait format, without a flap or gusset, made with one side seam-glued on outside of envelope. Made from our 120gsm White Heritage Archival pHotokraft™ paper.

Specifications

- Acid-free
- Lignin-free
- Colours: White as standard. Also available Neutral Grey, Taupe, Duke Parchment or Duplex Neutral Grey/White, prices on application. White is available in buffered or unbuffered. Unbuffered White is available in 90, 120, 170 and 230gsm.
- The 'L' Wallet can also be made from pHoton™ 100% cotton high-purity papers, prices on application

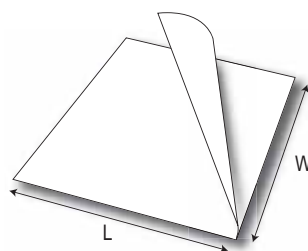

Product code	Type	Colour	Weight gsm/micron	Size mm	Size inches
DFGOS3867	Glued one side	Grey	120	254 x 229	10 x 9
DFGOS6601	Glued one side	Grey	120	260 x 195	10¼ x 7⅞
DFGOS8060	Glued one side	Old Grey Ivory	170	355 x 228	14 x 9
DFGOS3865	Glued one side	Grey	120	356 x 254	14 x 10
DFGOS3021	Glued one side	Grey/White	230mic	368 x 254	14½ x 10
DFGOS8328	Premier Archival Folder	Taupe	120	248 x 176	9¾ x 6⅞
DFGOS8377	Premier Archival Folder	Ivory	170	230 x 145	9⅞ x 5¾
DFGOS8378	Premier Archival Folder	Ivory	170	350 x 275	13⅝ x 10⅞
DFGOS8379	Premier Archival Folder	Ivory	170	490 x 350	19⅞ x 13⅝
DFGOS8592	Premier Archival Folder	Grey	170	265 x 210	10⅞ x 8⅞

Product code	Size mm L x W	Size inches L x W	Pack qty
DFGOS0077	70 x 70	2¾ x 2¾	50
DFGOS0710	70 x 100	2¾ x 3⅞	50
DFGOS1013	100 x 130	3⅞ x 5⅞	50
DFGOS1419	140 x 190	5⅜ x 7⅞	50
DFGOS1925	190 x 250	7⅜ x 9⅞	50
DFGOS2126	210 x 260	8⅞ x 10⅞	50
DFGOS2230	220 x 305	8⅞ x 12⅞	50
DFGOS2531	250 x 310	9⅞ x 12⅞	50
DFGOS3141	310 x 410	12⅞ x 16⅞	50
DFGOS3143	310 x 430	12⅞ x 16⅞	50
DFGOS4151	410 x 510	16⅞ x 20⅞	50
DFGOS5161	510 x 610	20⅞ x 24⅞	50
DFGOS5166	510 x 660	20⅞ x 25⅞	50
DFGOS4053	405 x 530	15⅞ x 20⅞	50
DFGOS6181	610 x 810	24⅞ x 31⅞	50
DFGOS5273	520 x 730	20⅞ x 28⅞	50

Open Topless Wallets/Pockets/Enclosures

STYLE CODE CF01

Premier™ and Premier Duo™ Topless Wallets and Pockets

Made from Premier Duo™ Grey/White or CXD Heritage Archival pHotokraft™ (HAPK) Paper, these envelopes are glued on both short seams, wallet contents are accessed from the top long edge. Some versions have a central top tab.

Applications

- Photograph and document storage

Linked Products: Open-Top Expansion Pocket p62.

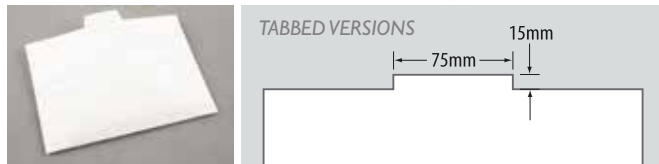

Product code	Type	Colour	Weight gsm/micron	Size mm	Size inches
FDPTP00148	A5 portrait, thumb cut	Grey	230gsm	160 x 240	6 ¹ / ₁₆ x 9 ¹ / ₁₆
FDPTP00210	A4 portrait, thumb cut	Grey	230gsm	230 x 320	9 ¹ / ₁₆ x 12 ³ / ₁₆
FDAWNF3822	Landscape	White	120gsm	341 x 225	13 ¹ / ₁₆ x 8 ⁷ / ₁₆
FDAWNF6151	Landscape	White	350gsm	182 x 133	7 ¹ / ₁₆ x 5 ¹ / ₄
FDAWNF6156	Landscape	Grey/White	300mic	562 x 409	22 ¹ / ₈ x 16 ¹ / ₈
FDAWNF6157	Landscape	Grey/White	300mic	406 x 279	16 x 11
FDAWNF3281	Landscape, Gusset	Grey	120gsm	345 x 229	17 ³ / ₆₄ x 9 ¹ / ₆₄
FDAWNF6344	No Flap, with gusset. Portrait	Grey	230gsm	315 x 408 x 35	12 ¹ / ₃₂ x 16 ¹ / ₁₆ x 1 ¹ / ₈
FDAWNF6363	Central Tab 75 x 15mm high	White	350gsm	126 x 94	5 x 3 ¹ / ₁₆
FDAWNF6364	Central Tab 75 x 15mm high	White	350gsm	179 x 133	7 x 5 ¹ / ₄
FDAWNF6365	Central Tab 75 x 15mm high	White	350gsm	239 x 178	9 ¹ / ₁₆ x 7
FDAWNF6160	Central Tab 75 x 15mm high	Grey	350gsm	375 x 265	14 ³ / ₄ x 10 ¹ / ₁₆
FDAWNF6776	Landscape	Grey	120gsm	370 x 260	14 ¹ / ₁₆ x 10 ¹ / ₄
FDAWNF7153	Landscape	Grey	120gsm	327x 230	12 ¹ / ₈ x 9 ¹ / ₁₆
FDAWNF8076	Landscape, thumb cut	White	120gsm	115 x 102	4 ¹ / ₃₂ x 4 ¹ / ₆₄
FDAWNF8077	Landscape, thumb cut	White	120gsm	229 x 102	9 ¹ / ₆₄ x 4 ¹ / ₆₄
FDAWNF8349	Premier Archival Wallets	White	170gsm	150 x 150	5 ⁹ / ₃₂ x 5 ⁹ / ₃₂
FDAWNF8350	Landscape	White	350gsm	179 x 160	7 ¹ / ₆₄ x 6 ¹ / ₆₄
FDAWNF8421	Landscape	Grey	90gsm	350 x 460	13 ¹⁵ / ₆₄ x 18 ¹ / ₆₄
FDAWNF6593	Central Tab pHoton™ 100% Cotton Wallets	White	250	134 x 190	5 ¹ / ₃₂ x 7 ³ / ₆₄
FDAWNF6997	Premier Archive Wallet	White	120	327 x 230	12 ¹ / ₈ x 9 ¹ / ₁₆

STYLE CODE CF02

Premier™ Microfiche Topless Wallet

Microfiche Topless Wallet with two glued outer seams, landscape format open on the top long edge. Designed for storage of microfiche, this wallet is suitable for our Premier Duo™ Microfiche Box (page 34). Made from our 120gsm White Heritage Archival pHotokraft™ Paper.

Specifications

- Acid-free
- Lignin-free
- Colours: White as standard
- Also available in Neutral Grey, Taupe, Duke Parchment or Duplex Neutral Grey/White, prices on application
- White is available in buffered or unbuffered
- Unbuffered White is available in 90, 120, 170 and 230gsm
- The 'L' Wallet can also be made from pHoton™ 100% cotton high-purity papers, prices on application

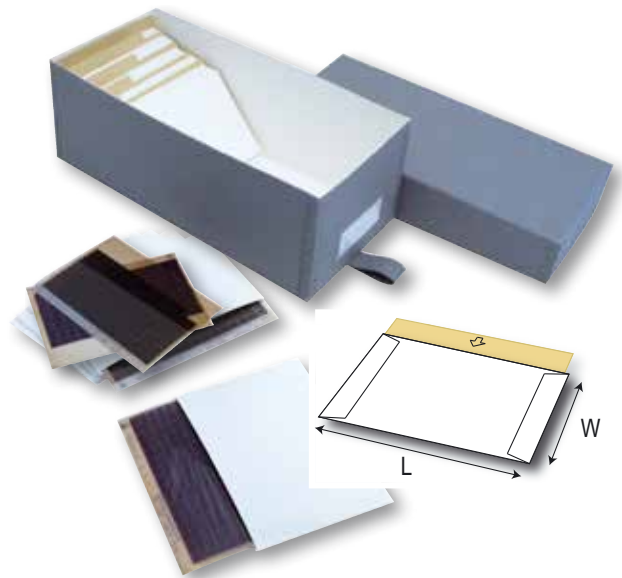

Product code	Size mm L x W	Size inches L x W	Pack qty
FDAWNF1611	160 x 110	6 ¹ / ₆₄ x 4 ² / ₆₄	50

STYLE CODE CF03

Visifiles™ Transparent Matt Polypropylene Plan Drawer and Artwork Folders

Open-top with carry handles

Made from inert 410 micron polypropylene sewn on 3 sides and creased one third of the way down to assist access to contents. On the open edge there are cut-outs which can be used for removing a folder from a drawer or to carry it.



Special sizes and design variations are also undertaken. Sizes as large as 2 x 1.5 metres have been made. Visifiles™ can be used for single items or multiples of maps, photographs, plans etc. Almost indestructible they can be used to carry heavy loads without fear of the handles tearing. Visifiles™ can also be ordered punched to fit all vertical storage systems.

Visifiles™ folders in A2, A1 and A0 sizes are also designed to fit inside the CXD 'Big Yella Bag™' Transfolio™ Bag heavy-duty portfolio.

Specifications

- Inert 500 micron polypropylene
- Sewn on 3 sides and creased one third of the way down
- Integral heavy-duty carrying handles
- Can be ordered punched to fit all vertical storage systems
- Special sizes and design variations subject to quantity required

Applications

- Plan drawer map and artwork folders

Linked Products: Big Yella Bag™ p79; Transfolio™ Bag Portfolio p79.

Product code	Type	Thickness micron	Internal size mm	Internal size inches	External size mm	Pack qty
FDVFLX0420	A3 Landscape	500	320 x 430	16 ⁵ / ₁₆ x 12 ² / ₁₆	390 x 462	10
FDVFLX0594	A2 Landscape	500	440 x 605	23 ³ / ₁₆ x 17 ⁷ / ₁₆	505 x 635	10
FDVFLX0841	A1 Landscape	500	605 x 845	23 ³ / ₁₆ x 33 ¹ / ₄	680 x 880	10
FDVFLX1189	A0 Landscape	500	865 x 1200	47 ¹ / ₄ x 34 ¹ / ₁₆	910 x 1230	10
FDVFPX0594	A2 Portrait	500	605 x 440	23 ³ / ₁₆ x 17 ⁷ / ₁₆	480 x 680	10
FDVFPX0841	A1 Portrait	500	605 x 845	23 ³ / ₁₆ x 33 ¹ / ₄	645 x 910	10

All are matt transparent polypropylene

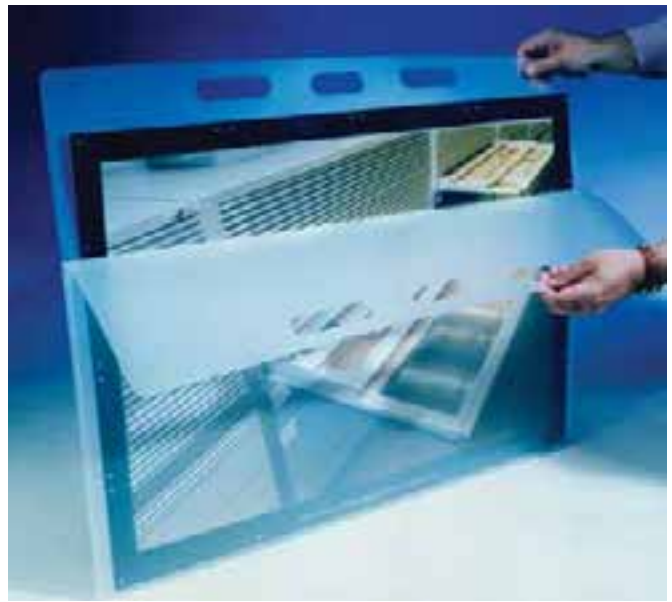

Special sizes and design variations are also undertaken with sizes as large as 2 x 1.5 metres available.



A2 Landscape

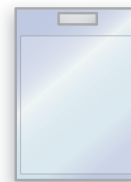

A3 Portrait



SMART SERVICE
custom-made folders
available for this product



A1 Portrait

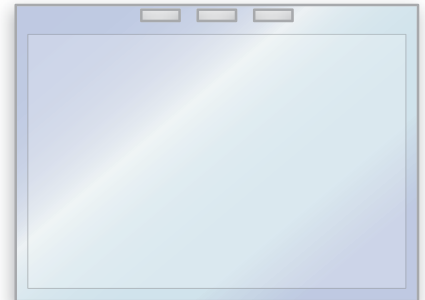

A0 Landscape

Planorama® Aluminium Plan Chest and Storage Drawers



Big Yella Bag™



Premier™ and Premier Duo™ Record Sleeves for 33, 45 and 78 rpm Vinyl Discs

These record sleeves are made from 300 micron Premier Duo™ Grey/White or 120gsm Heritage Archival pHotokraft™ paper. They are available with or without two 89mm (3½") diameter label apertures on both sides. FDAEWF3456/4687/4688 have two side seams glued on the outside edges to avoid internal abrasion.

Specifications

- Acid-Free
- Lignin-free
- Made from Premier Duo™ or CXD Heritage Archival pHotokraft™ Paper
- Available in Grey and Grey/White as standard



Product code	Description	Colour	Weight gsm	Size mm L x W	Size inches L x W	Pack qty
FDAEWF0033	12" Record Sleeve – with Aperture Ø90mm – no Flap	Grey	120	305 x 305	12¼ x 12¼	25
FDAEWF0078	10" Record Sleeve – with Aperture Ø90mm – no Flap	Grey	120	260 x 260	10½ x 10½	25
FDAEWF0045	7" Record Sleeve – with Aperture Ø60mm – with Flap	Grey	120	180 x 180	7½ x 7½	25
FDAEWF3456	10" Record Sleeve – with Aperture Ø90mm – no Flap	Grey/White	240	261 x 261	10½ x 10½	100
FDAEWF4687	10" Record Sleeve – no Aperture – with Flap	Grey/White	240	267 x 260	10¾ x 10½	100
FDAEWF4688	12" Record Sleeve – no Aperture – no Flap	Grey/White	240	311 x 311	12¼ x 12¼	100

pHoton™ Stitch in Timecare® Enclosures Special Designs for Storage of Negatives and Transparencies



A unique system of tailor-made negatives storage envelopes made from pHoton™ high-purity, unbuffered paper. The paper is sewn with cotton thread to form enclosures which avoid the use of adhesives for the safest possible long-term storage of photographic negatives and prints.

An inspired example of design which proves that 'less is more' safe when the use of simple time-tested methods and raw materials are combined with high-technology production and scientific quality control systems. pHoton™ Storage Papers pass ANSI photographic activity test IT9.2 (ISO 10214).

Sleeves with integral suspension bars are for use in A4 Suspension Filing Systems only*. Sleeves without suspension bars can be combined with A4 Crimpon Suspension Bars or Folio Timecare® Hanging Bars.



The pHoton™ paper is sewn with cotton thread

Product code	Type	Colour	Weight gsm ²	Env. Size mm	Env. Size inches	Pack qty
PHNSE4505	A4/3 pockets	White	80	243 x 308	8¼ x 10½	25
PHNSE4506	A4/7 pockets	White	80	243 x 308	8¼ x 10½	25
PHNSE4507	A4/4 pockets	White	80	243 x 308	8¼ x 10½	25
PHNSE4509*	A4/7 pockets	White	80	244 x 308	8¼ x 10½	25
PHNSE4516*	A4/12 pockets	White	80	244 x 308	8¼ x 10½	25
PHNSE4517*	A4/4 pockets	White	80	244 x 308	8¼ x 10½	25
PHNSE4518	A4/7 pockets	White	80	243 x 308	8¼ x 10½	25
PHSTIT0509*	A4/1 pocket	White	250	244 x 308	8¼ x 10½	25

*With integral suspension bars

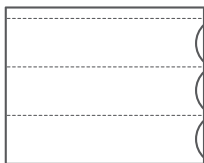

PHNSE4505
60mm negatives and transparencies
3 Pockets

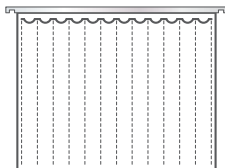

PHSTIT0509
35mm negatives and transparencies
7 Pockets with integral suspension bar



Without suspension bar



With integral suspension bar

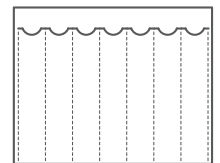

PHNSE4518
35mm negatives and transparencies A4
7 Pockets

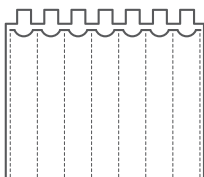

PHNSE4506
35mm negatives and transparencies A4
7 pockets, looped suspension

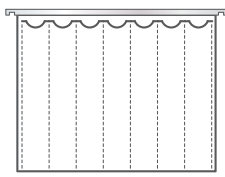

PHNSE4516
Single negatives and transparencies
12 Pockets (60 x 60, 60 x 70, 60 x 90)

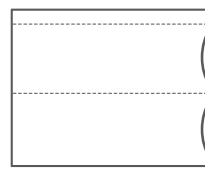

PHNSE4507
70mm negatives and transparencies
A4 4 Pockets (2 Pockets Front and 2 Pockets Back)

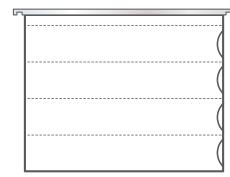

PHNSE4517
70mm negatives and transparencies
4 Pockets (2 front, 2 back)

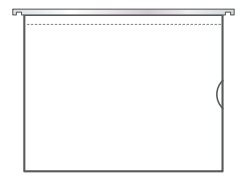

PHNSE0509
Hanging File
1 Pocket

STYLE CODE CF06

Hanging Bar

For use with Stitch in Timecare® *pHoton*™ Negative and Print Storage System (above).



SUHBAR7009 A4 Crimpon Suspension Bar for use with PHSNSE4505/4506/4507/4518

Product code	Type	Size mm	Size inches	Pack qty
SUHBAR7009	Foolscap/Folio	406 overall	16	10

STYLE CODE CF07

pHoton™ Concertina Folder

Single piece die-cut with concertina folds to make 6 Pockets for 35, 60 and 70mm negatives and transparencies.

Approx. 1m in length when opened-out.

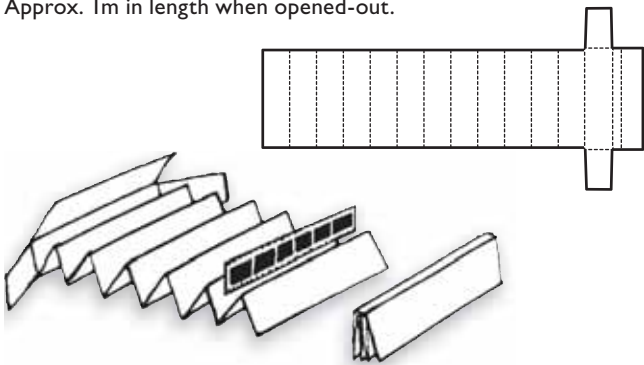

Product code	Colour	Thickness gsm	External dimensions mm	Internal dimensions mm	Pack qty
PHCONC4522	White	80	270 x 75	260 x 70	25

STYLE CODE CF09

Polyester Perforated Insertion Strip

These self-adhesive polyester strips are punched with universal perforations which can be adapted to fit most ringbinders. The strips can be attached to an envelope, a sleeve or a periodical which can then be inserted into a ringbinder. This is a very handy product and easy to use.

This product is extremely sturdy and chemically neutral (polyester + acrylic adhesive).

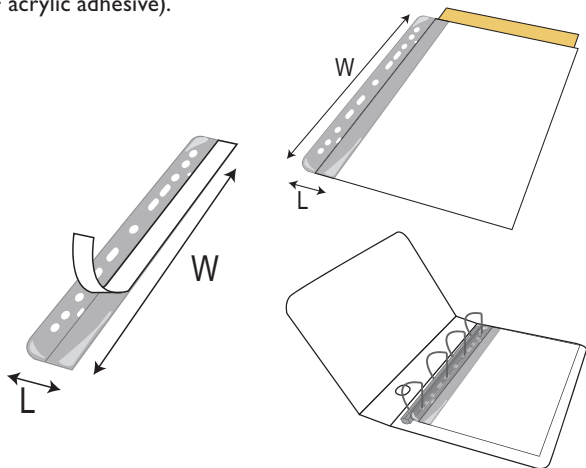

Product code	Size mm W x L	Size inches W x L	Pack qty
SUSUSS0295	295 x 25	11 ³⁹ / ₆₄ x ⁶³ / ₆₄	100

STYLE CODE CF40

pHoton™ 100% Cotton Envelope

Made from 80gsm *pHoton*™ high-purity 100% cotton paper which is un-sized and very low in calcium carbonate and other trace elements with a pH of 6.7. These die-cut envelopes are glued with specially formulated Evacon-R™ conservation adhesive, opening on one narrow edge. Without flap or gusset unless specified.

Only the ANE22 coin envelope is supplied with a cover flap.

Specifications

- Un-sized
- Glued with specially formulated Evacon-R™ conservation adhesive
- Available in White - 80gsm



Applications

- Photographic negatives, glass plates, land plates and coins



Product code	Type	Style ref	Colour	Weight gsm	Size mm	Size inches
FDCPNE8022	Coins (with 20mm flap)	ANE22	White	80	51 x 51	2 x 2
FDCPNE8023	60 x 80mm negatives	ANE23	White	80	64 x 89	2½ x 3½
FDCPNE8045	4" x 5" negatives	ANE45	White	80	111 x 137	4¾ x 5¾
FDCPNE8034	Single 120mm negatives	ANE34C	White	80	89 x 114	3½ x 4½
FDCPNE8046	4" x 6" negatives	ANE46B	White	80	156 x 107	6¼ x 4¾
FDCPNE8056	4¾" x 6½" plates	ANE56	White	80	127 x 172	5 x 6¾
FDCPNE8057	5" x 7" plates Portrait	ANE57	White	80	137 x 187	5½ x 7½
FDCPNE8068	Whole plate negatives	ANE68	White	80	172 x 222	6¾ x 8¾
FDCPNE8081	8" x 10" negatives	ANE810	White	80	216 x 267	8½ x 10½
FDCPNE8021	35mm film negatives	ANE210	White	80	64 x 273	2½ x 10¾
FDCPNE8010	10" x 12" plates	ANE1012	White	80	260 x 311	10¼ x 12¼
FDCPNE8011	11" x 14" land plates	ANE1114	White	80	292 x 368	11½ x 14½
FDCPNE6981	<i>pHoton</i> 100% Cotton Envelope	CF40	White	80	115 x 90	4 ¹⁷ / ₃₂ x 3 ⁵ / ₆₄
FDCPNE8146	<i>pHoton</i> 100% Cotton Envelope	CF40	White	80	172 x 121	6 ⁴⁹ / ₆₄ x 4 ⁴⁹ / ₆₄

All in packs of 25

Envelopes/Wallets/Pockets with Flap

STYLE CODE DF01

Premier Duo™ Envelope with Flap

Made from a choice of Premier Duo™ 240gsm/300micron duplex neutral Grey/White or 230gsm and 120gsm Heritage Archival pHotokraft™ (HAPK) Paper.

Originally designed by Christopher Clarkson these Bodleian Library shelf envelopes are made for the safe storage of documents and photographs. Wallet style with two side seams to provide rigidity and avoid pressure marks. To help avoid unnecessary damage during use, some envelopes have radiused corners on the flap and are embossed with a border line to indicate the maximum advisable size of item the envelope should take.

The range has been extended, at the request of customers, which has greatly increased the choice of sizes available.

Heritage Archival pHotokraft™

These folders can also be supplied in any colour or weight from the Heritage Archival pHotokraft™ paper (HAPK) range including White, Duke Parchment, Neutral Grey, Taupe and Old Grey Ivory. White also available unbuffered. Prices on application.



Specifications

- Acid-free
- Lignin-free
- Made from CXD Heritage Archival pHotokraft™ paper
- Available with or without flaps



Applications

- Safe storage of letters, pamphlets, documents, photographs and negatives

Product code	Description	Embossed border	Style ref	Colour	Weight gsm/micron	Internal size mm	Internal size inches
FDAEWF0296	with Flap - Bodleian	Yes	EE1	Grey/White	230mic	197 x 140	7¾ x 5½
FDAEWF0018	with Flap - Bodleian	Yes	EE3	Grey/White	230mic	222 x 146	8¾ x 5¾
FDAEWF0295	with Flap - Bodleian 95mm	Yes	ED1	Grey/White	230mic	241 x 191	9½ x 7½
FDAEWF0019	with Flap - Bodleian 104mm	Yes	ED3	Grey/White	230mic	267 x 203	10½ x 8
FDAEWF0297	with Flap - Bodleian 114mm	Yes	ED5	Grey/White	230mic	292 x 229	11½ x 9
FDAEWF1610	with Flap - Bodleian 114mm	Yes	ED7 (A4)	Grey/White	230mic	318 x 229	12½ x 9
FDAEWF0013	with Flap - Bodleian Foolscap/Folio	Yes	EC1	Grey/White	230mic	343 x 267	13½ x 10½
FDAEWF0267	with Flap - Bodleian 120mm	Yes	EC3	Grey/White	230mic	368 x 241	14½ x 9½
FDAEWF1075	with Flap - Bodleian 140mm	Yes	EC5	Grey/White	230mic	368 x 279	14½ x 11
FDAEWF0429	with Flap - Bodleian	Yes	EC7	Grey/White	230mic	368 x 298	14½ x 11¾
FDAEWF0859	with Flap - Bodleian 152mm	Yes	EB1	Grey/White	230mic	406 x 305	16 x 12
FDAEWF6381	with Flap 51mm	No		White	120	102 x 127	4 x 5
FDAEWF6382	with Flap 66mm	No		White	120	134 x 178	5¼ x 7
FDAEWF6152	with Flap	No		Grey	120	140 x 140	5½ x 5½
FDAEWF2724	with Flap 27mm	No		White	120	152 x 102	6 x 4
FDAEWF3689	with 134mm Flap	No, thumb cut		Grey/White	230mic	184 x 137	7¼ x 5¾
FDAEWF6158	with 76mm Flap	Yes		Grey/White	230mic	210 x 217	8¼ x 8¾
FDAEWF6383	with 50mm Flap	No		White	120	221 x 171	8⅞ x 6¾
FDAEWF6027	with 40mm Flap	No		White	120	260 x 160	10¼ x 6⅞
FDAEWF4192	with 76mm Flap	No		White	120	267 x 318	10½ x 12½
FDAEWF2378	with Flap 76mm	Yes	4661	Grey/White	230mic	278 x 150	10⅞ x 5⅞
FDAEWF6073	with 50mm Flap	No		Grey	230	307 x 181	12⅞ x 7⅞
FDAEWF4170	with 76mm Flap	Yes		White	120	311 x 260	12¼ x 10¼
FDAEWF6394	with 102mm Flap	No		White	120	318 x 127	12½ x 5
FDAEWF4663	with 75mm Flap	Yes		Grey/White	230mic	340 x 150	13⅜ x 5⅞
FDAEWF4664	with 115mm Flap	Yes		Grey/White	230mic	343 x 229	13½ x 9
FDAEWF6639	with 148mm Flap	Yes		Grey/White	230mic	350 x 310	13¾ x 12⅞
FDAEWF6155	with 110mm Flap	Yes		Grey/White	230mic	368 x 250	14½ x 9⅞
FDAEWF2556	with 165mm Flap	No		Grey/White	230mic	370 x 177	14⅞ x 6⅞
FDAEWF4713	with 140mm Flap	No		Grey/White	230mic	380 x 255	14⅞ x 10⅞
FDAEWF2379	with Flap	No	4665	Grey/White	230mic	406 x 229	16 x 9
FDAEWF6286	with 120mm Flap	Yes		Grey/White	230mic	407 x 280	16 x 11
FDAEWF6079	with 55mm Flap	Yes		White	120	507 x 378	19⅞ x 14⅞
FDAEWF6319	with Flap	No		Grey/White	230mic	514 x 414	20¼ x 16⅞
FDAEWF2237	Premier Archival Envelope		DF01	Grey/White	300mic	117 x 93	4⅞ x 3⅞
FDAEWF8146	Archive Envelope With Flap		DF01	Cream	120gsm	260 x 185	10⅞ x 7⅞
FDAEWF8327	Premier Archival Envelope		DF01	Grey/White	300mic	110 x 150	4⅞ x 5⅞
FDAEWF8426	Archive Envelope With Flap		DF01	White	120gsm	235 x 185	9¼ x 7⅞

Please note more sizes available on request. Bodleian System Envelopes are all landscape.

STYLE CODE DF02

Premier Duo™ Boxboard-Backed Pocket Envelopes

Archival Pocket Envelope with non-adhesive flap, made from 120gsm White Heritage Archival pHotokraft™ paper with a Premier Duo™ Grey/White boxboard back offering maximum protection for fragile objects. This envelope has two side seams glued on the outside to avoid internal abrasion.

Specifications

- Acid-free
- Lignin-free
- Made from Premier Duo™ Neutral Grey/White Boxboard and CXD Heritage Archival pHotokraft™ paper
- Available in Grey/White as standard



Product code	Size mm L x W	Size inches L x W	Pack qty
FDPCBE1519	150 x 190	5 ²⁹ / ₃₂ x 7 ³¹ / ₆₄	50
FDPCBE2025	200 x 250	7 ⁷ / ₈ x 9 ²⁷ / ₃₂	50
FDPCBE2332	230 x 320	9 ¹ / ₁₆ x 12 ¹⁹ / ₃₂	50
FDPCBE2633	260 x 330	10 ¹⁵ / ₆₄ x 12 ⁶³ / ₆₄	50

STYLE CODE DF04

Premier™ Pocket Envelopes for CDs

This Pocket Envelope offers lasting protection against atmospheric pollutants which can damage the coating of the CD. The paper used includes an alkaline reserve which neutralises any acids. With two glued outer side seams and open on one side with 25mm non-adhesive flap. Made in 120gsm White Heritage Archival pHotokraft™ paper.

Specifications

- Acid-free
- Lignin-free
- CXD Heritage Archival pHotokraft™ (HAPK) Paper



Product code	Size mm L x W	Size inches L x W	Pack qty
FDAFEN1212	126 x 126	4 ⁶ / ₆₄ x 4 ⁶ / ₆₄	50

STYLE CODE DF03

Premier™ Envelope with Flap

Archival Envelope with Flap, made from our 120gsm White Heritage Archival pHotokraft™ paper. Open on one long side with a full flap ensuring maximum security of the contents.

Specifications

- Acid-free
- Lignin-free
- OBA-free



Product code	W x L mm	W x L inches	Pack qty
FDAEWF7510	75 x 105	2 ⁶ / ₆₄ x 4 ¹ / ₆₄	50
FDAEWF1014	105 x 140	4 ¹ / ₆₄ x 5 ³ / ₆₄	50
FDAEWF1419	140 x 190	5 ³ / ₆₄ x 7 ³¹ / ₆₄	50
FDPCBE1519	150 x 190	5 ²⁹ / ₃₂ x 7 ³¹ / ₆₄	50
FDAEWF1925	190 x 250	7 ³¹ / ₆₄ x 9 ²⁷ / ₃₂	50
FDPCBE2025	200 x 250	7 ⁷ / ₈ x 9 ²⁷ / ₃₂	50
FDAEWF0004	220 x 315	8 ²¹ / ₃₂ x 12 ¹³ / ₃₂	50
FDPCBE2332	230 x 320	9 ¹ / ₁₆ x 12 ¹⁹ / ₃₂	50
FDAEWF2531	250 x 310	9 ²⁷ / ₃₂ x 12 ¹³ / ₆₄	50
FDAEWF2533	250 x 330	9 ²⁷ / ₃₂ x 12 ⁶³ / ₆₄	50
FDPCBE2633	260 x 330	10 ¹⁵ / ₆₄ x 12 ⁶³ / ₆₄	50
FDAEWF3141	310 x 410	12 ¹³ / ₆₄ x 16 ¹ / ₆₄	50

STYLE CODE DF05

Premier™ Archival Pocket Envelope with Flap

Archival Pocket Envelope with (non-adhesive) Flap, opening on the short or long edge depending on size. This envelope has two side seams glued on the outside to avoid internal abrasion. With a 6cm non-adhesive flap. Made in our 120gsm Neutral Grey Heritage Archival pHotokraft™ Paper.

Specifications

- Acid-free
- Lignin-free
- CXD Heritage Archival pHotokraft™ (HAPK) Paper

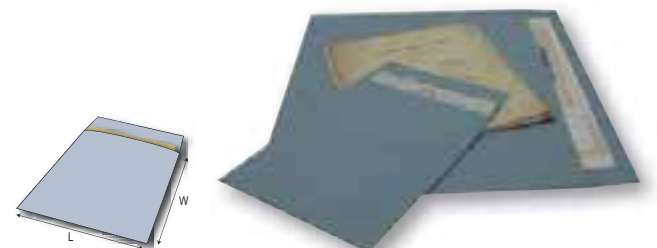

Product code	Size mm L x W	Size inches L x W	Pack qty
FDAFEN1519	150 x 195	5 ²⁹ / ₃₂ x 7 ⁴ / ₆₄	50
FDAFEN2025	200 x 255	7 ⁷ / ₈ x 10 ¹ / ₆₄	50
FDAFEN2432	240 x 320	9 ³ / ₆₄ x 12 ¹⁹ / ₃₂	50
FDAFEN2633	260 x 335	13 ³ / ₁₆ x 13 ³ / ₁₆	50
FDAFEN3547	355 x 470	13 ³ / ₃₂ x 18 ¹ / ₂	50
FDAFEN3753	375 x 530	14 ⁶ / ₆₄ x 20 ⁵ / ₆₄	50

Pocket Envelopes with Non-Adhesive Flap

STYLE CODE EF01

Archival Pocket Envelopes with Non-Adhesive Flap

Made from CXD Heritage Archival pHotokraft™ Paper, these pocket envelopes have round corner side seams throughout and have a 51mm non-adhesive flap.

Available in a wide choice of colours. Special makings in other weights with a printing service available on request.

Specifications

- Acid-free
- Lignin-free
- CXD Heritage Archival pHotokraft™ (HAPK) Paper

LONG LIFE
ISO 9706
PAT
ISO 18916

Applications

- Negative, photograph and document storage

FDAFEN0710



Product code	Description	Orientation	Colour	Weight gsm	Size mm	Size inches
FDAFEN8539	Envelope	Portrait	Ivory	120	102 x 152	4 ¹ / ₆₄ x 5 ⁹ / ₆₄
FDAFEN0125	CD Envelope	Portrait	White	120	125 x 145	4 ⁹ / ₆₄ x 5 ¹¹ / ₆₄
FDAFEN0514	Envelope	Portrait	White	120	133 x 356	5 ¹ / ₆₄ x 14 ¹ / ₆₄
FDAFEN0069	A5	Portrait	White	120	152 x 229	5 ⁹ / ₆₄ x 9 ¹ / ₆₄
FDAFEN8111	Envelope	Landscape	White	120	152 x 229	5 ⁹ / ₆₄ x 9 ¹ / ₆₄
FDAFEN6552		Portrait	White	120	175 x 253	6 ⁷ / ₆₄ x 9 ¹ / ₆₄
FDAFEN0710		Portrait	White	120	191 x 267	7 ³ / ₆₄ x 10 ³ / ₆₄
FDAFEN8129	Envelope	Landscape	White	120	191 x 267	7 ³ / ₆₄ x 10 ³ / ₆₄
FDAFEN0912		Portrait	White	120	229 x 305	9 x 12
FDAFEN8261	Envelope	Portrait	Grey	120	229 x 152	9 ¹ / ₆₄ x 5 ⁹ / ₆₄
FDAFEN6419		Portrait	White	120	230 x 160	9 ¹ / ₆₄ x 6 ¹ / ₆₄
FDAFEN0914		Portrait	White	120	241 x 375	9 ¹ / ₂ x 14 ³ / ₄
FDAFEN6865	Envelope	Landscape	White	120	241 x 375	9 ¹ / ₆₄ x 14 ⁹ / ₆₄
FDAFEN1015		Portrait	White	120	254 x 381	10 x 15
FDAFEN8260	Envelope	Portrait	Grey	120	305 x 229	12 ¹ / ₆₄ x 9 ¹ / ₆₄
FDAFEN8360	Envelope	Portrait	White	120	305 x 254	12 ¹ / ₆₄ x 10
FDAFEN6860	Envelope	Landscape	White	120	305 x 229	12 ¹ / ₆₄ x 9 ¹ / ₆₄
FDAFEN6821	Envelope	Portrait	Grey	230	334 x 434	13 ³ / ₃₂ x 17 ³ / ₃₂
FDAFEN6849	Envelope	Portrait	White	120	355 x 229	13 ³ / ₃₂ x 9 ¹ / ₆₄
FDAFEN6942	Envelope	Landscape	White	120	381 x 457	15 x 17 ⁹ / ₆₄
FDAFEN8201	Envelope	Portrait	White	120	340 x 220	13 ² / ₆₄ x 8 ³ / ₃₂
FDAFEN6461		Portrait	White	120	370 x 160	14 ¹ / ₆₄ x 6 ¹ / ₆₄
FDAFEN822		Portrait	Grey	230	384 x 484	15 ¹ / ₆₄ x 19 ¹ / ₆₄
FDAFEN6940	Envelope	Portrait	White	120	385 x 470	15 ¹ / ₃₂ x 18 ¹ / ₂
FDAFEN8187	Envelope	Portrait	White	120	390 x 160	15 ² / ₆₄ x 6 ¹ / ₆₄
FDAFEN6580	Envelope	Portrait	White	120	420 x 170	16 ¹ / ₃₂ x 6 ¹ / ₆₄
FDAFEN8558	Envelope	Portrait	White	120	430 x 307	16 ⁹ / ₆₄ x 12 ¹ / ₃₂
FDAFEN6809		Landscape	White	120	445 x 267	17 ¹ / ₂ x 10 ¹ / ₂

Gusseted Expansion Wallets

STYLE CODE GF01

Expanding Gusseted Folder

Made from CXD Heritage Archival pHotokraft™ Paper or Premier Duo™ Duplex Grey/White, these die-cut envelopes are glued on both short seams. Folder contents are accessed from the top long edge beneath a non-adhesive flap and have an expansion gusset.



SMART SERVICE
custom-made folders
available for this product

Product code	Type	Colour	Weight gsm	Thickness microns	Size mm	Size inches	Orientation*
FDEGFF6417	-	White	120		175 x 253 x 45	6 ⁷ / ₆₄ x 9 ¹ / ₆₄ x 1 ¹ / ₄	Portrait
FDEGFF6768	-	White	120		175 x 253 x 45	6 ⁷ / ₆₄ x 9 ¹ / ₆₄ x 1 ¹ / ₄	Portrait
FDEGFF6850	-	White	120		355 x 229 x 45	13 ³ / ₃₂ x 9 ¹ / ₆₄ x 1 ¹ / ₆₄	Portrait
FDEGFF4281	-	Grey/White		300	447 x 332 x 38	17 ⁷ / ₆₄ x 13 ¹ / ₆₄ x 1 ¹ / ₂	Landscape
FDEGFF3755	A4	Grey/White		300	311 x 260 x 38	12 ¹ / ₄ x 10 ¹ / ₄ x 1 ¹ / ₂	Landscape
FDEGFF6153	-	Grey/White		300	322 x 230 x 25	12 ¹ / ₆₄ x 9 ¹ / ₆₄ x 1	Landscape
FDEGFF6026	-	White	120		330 x 260 x 20	13 x 10 ¹ / ₄ x 1 ¹ / ₆₄	Landscape
FDEGFF6161	-	Grey/White		300	346 x 221 x 30	13 ³ / ₆₄ x 8 ¹ / ₆₄ x 1 ¹ / ₆₄	Landscape
FDEGFF6159	-	Grey/White		300	355 x 265 x 38	14 x 10 ¹ / ₆₄ x 1 ¹ / ₂	Landscape
FDEGFF0570	-	Grey/White		300	356 x 238 x 38	14 x 9 ¹ / ₆₄ x 1 ¹ / ₂	Landscape
FDEGFF4380	Folio	Grey	120		375 x 260 x 38	14 ³ / ₄ x 10 ¹ / ₄ x 1 ¹ / ₂	Landscape
FDEGFF3841	Folio	Grey/White		300	375 x 260 x 38	14 ³ / ₄ x 10 ¹ / ₄ x 1 ¹ / ₂	Landscape
FDEGFF4732	-	Grey/White		300	387 x 292 x 38	15 ¹ / ₄ x 11 ¹ / ₂ x 1 ¹ / ₂	Landscape
FDEGFF6430	-	Grey/White		300	420 x 290 x 30	16 ¹ / ₆₄ x 11 ¹ / ₆₄ x 1 ¹ / ₆₄	Landscape
FDEGFF4381	A4	Grey	120		311 x 260 x 38	12 ¹ / ₄ x 10 ¹ / ₄ x 1 ¹ / ₂	Landscape
FDEGFF4280	-	Grey/White		300	544 x 396 x 38	2 ¹ / ₆₄ x 15 ¹ / ₆₄ x 1 ¹ / ₂	Landscape
FDEGFF8187		White	120		390 x 160 x 50	15 ³ / ₆₄ x 6 ³ / ₆₄ x 1 ¹ / ₃₂	Portrait
FDEGFF8317		Grey	350		405 x 305 x 50	15 ⁵ / ₆₄ x 12 ¹ / ₆₄ x 1 ¹ / ₃₂	Landscape
FDEGFF8342			230		375 x 260	14 ⁹ / ₆₄ x 10 ¹ / ₆₄	Landscape

* When we refer to 'Landscape' we mean long side opening. 'Portrait' means short side opening.

STYLE CODE GF02

Premier™ Expanding Gusseted Pocket Envelope

Expanding Gusseted Pocket Envelope with flap for filing and protection of documents and books pending restoration.

Envelope with expansion to 45mm, open on one short side with flap. With one centre seam and bottom seam.

Made from 120gsm Neutral Grey Heritage Archival pHotokraft™ Paper.



Specifications

- Acid-free
- Lignin-free
- CXD Heritage Archival pHotokraft™ (HAPK) Paper

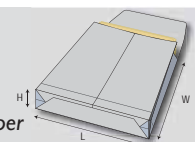

Product code	Size mm L x W x H	Size inches L x W x H	Pack qty
FDEGFF1318	130 x 180 x 45	5 ¹ / ₆₄ x 7 ¹ / ₃₂ x 1 ⁹ / ₆₄	50
FDEGFF1420	140 x 200 x 45	5 ³ / ₆₄ x 7 ⁷ / ₆₄ x 1 ⁹ / ₆₄	50
FDEGFF1521	150 x 210 x 45	5 ² / ₃₂ x 8 ¹ / ₆₄ x 1 ⁹ / ₆₄	50
FDEGFF0019	170 x 190 x 45	6 ¹ / ₆₄ x 7 ³ / ₆₄ x 1 ⁹ / ₆₄	50
FDEGFF1724	170 x 240 x 45	6 ¹ / ₆₄ x 9 ² / ₆₄ x 1 ⁹ / ₆₄	50
FDEGFF0025	170 x 250 x 45	6 ¹ / ₆₄ x 9 ² / ₃₂ x 1 ⁹ / ₆₄	50
FDEGFF1826	180 x 260 x 45	7 ¹ / ₃₂ x 10 ¹ / ₆₄ x 1 ⁹ / ₆₄	50
FDEGFF1928	190 x 280 x 45	7 ³ / ₆₄ x 11 ¹ / ₃₂ x 1 ⁹ / ₆₄	50
FDEGFF0030	200 x 300 x 45	7 ⁷ / ₆₄ x 11 ¹ / ₆₄ x 1 ⁹ / ₆₄	50
FDEGFF0297	210 x 300 x 30	8 ¹ / ₆₄ x 11 ¹ / ₆₄ x 1 ¹ / ₆₄	50
FDEGFF0033	260 x 330 x 45	10 ¹ / ₆₄ x 12 ² / ₆₄ x 1 ⁹ / ₆₄	50

Four-Flap Folders

STYLE CODE HF01

Premier Duo™ Archival Flap Folder

Made from CXD Premier Duo™ Archival Folding Boxboard laminated from Heritage Archival pHotokraft™ Paper these 650 micron, single-piece portfolio style folders were designed by Christopher Clarkson as part of the Bodleian Library storage system. See section on Clarkson Bodleian System, page 7.

They are pre-creased to give two depth settings and pre-slotted for the insertion of 13mm (½”) Cotton Tying Tape (not provided).

 *Linked Products: Cotton Tying Tapes p135.*



Product code	Description	Ref	Colour	Thickness microns	Size mm	Size inches	Orientation
FDDCFF1605	with tape slots	FF34	Grey/White	650	171 x 114 x 19	6¼ x 4½ x ¾	Portrait
FDDCFF1606	with tape slots	FE12	Grey/White	650	197 x 140 x 19	7¾ x 5½ x ¾	Portrait
FDDCFF1607	with tape slots	FE34	Grey/White	650	222 x 146 x 19	8¾ x 5¾ x ¾	Portrait
FDDCFF1048	with tape slots	FD12	Grey/White	650	241 x 191 x 19	9½ x 7½ x ¾	Portrait
FDDCFF1608	with tape slots	FD34	Grey/White	650	267 x 203 x 19	10½ x 8 x ¾	Portrait
FDDCFF1838	with tape slots	FD56	Grey/White	650	292 x 229 x 19	11½ x 9 x ¾	Portrait
FDDCFF0553	with tape slots. A4	FD78	Grey/White	650	318 x 229 x 19	12½ x 9 x ¾	Portrait
FDDCFF0014	with tape slots	FC12	Grey/White	650	343 x 267 x 19	13½ x 10½ x ¾	Portrait
FDDCFF1173	with tape slots. Folio	FC34	Grey/White	650	368 x 241 x 19	14½ x 9½ x ¾	Portrait
FDDCFF1076	with tape slots	FC56	Grey/White	650	368 x 279 x 19	14½ x 11 x ¾	Portrait
FDDCFF1077	with tape slots	FC78	Grey/White	650	368 x 298 x 19	14½ x 11¾ x ¾	Portrait
FDDCFF0498	with tape slots	FB12	Grey/White	650	406 x 305 x 19	16 x 12 x ¾	Portrait
FDDCFF3566	with tape slots	FB34	Grey/White	650	432 x 305 x 19	17 x 12 x ¾	Portrait

Choice of two integral crease lines to provide a depth of 12mm or 19mm

Specifications

- Acid-free
- Lignin-free
- OBA-free
- Made from CXD Premier Duo™ Archival Folding Boxboard
- Cruciform-shaped with four flaps
- Available in Premier Duo™ Neutral Grey/White



Applications

- Book, pamphlet and document storage

STYLE CODE HF02

Premier Duo™ Clam Self-Locking, Multi-Crease Folder

The clam self-locking design closes firmly without the need for tying tape. It has four flaps and is multi-creased to allow for expansion.

Product code	Description	Colour	Thickness microns	Size mm	Size inches
FDMCWR4209	A5 Clam (CF3)	Grey/White	650	228 x 178 x 23	9 x 7 x ⅞
FDMCWR0000	A4 Clam	Grey/White	650	305 x 221 x 23	12 x 8¾ x ⅞
FDMCWR4148	Folio Clam (CF1)	Grey/White	650	362 x 235 x 23	14¼ x 9¼ x ⅞
FDMCWR3798	A3 Clam (CF2)	Grey/White	650	425 x 302 x 26	16¾ x 11⅞ x 1

Folio, A4, A5: Choice of two integral crease lines to provide a depth of 12 or 23mm.
A3: Choice of two crease lines to provide depth of 12 or 26mm.

Specifications

- Acid-free
- Lignin-free
- OBA-free
- Premier Duo™ Archival Folding Boxboard
- Cruciform shaped with four flaps
- Available in Duplex Neutral Grey/White as standard



FDMCWR0000

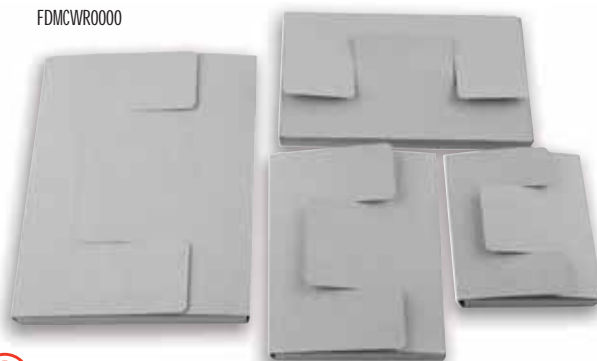

FDDCFF0553



FDDCFF1173



Applications

- Storage of documents



STYLE CODE HF03

Premier™ and Premier Duo™ Four-Flap Folder

Made from CXD Premier Duo™ Archival Folding Boxboard these single-piece folders are cruciform-shaped and have four flaps with multiple creases to cope with the variable thickness.

Special sizes on request. Folders can also be supplied in any colour or weight from the Heritage Archival pHotokraft™ Paper range including Duke Parchment, Neutral Grey, Taupe and Old Grey Ivory – prices on application.



STYLE CODE HF03

Premier Duo™ Four-Flap Folder with Velcro® Fastener

Four-flap, multi-crease folder with 5 creases on each flap providing a depth up to 35mm. Fitted with Velcro® fasteners.

Made in 1000 micron Grey/White Premier Duo™ Grey/White Boxboard. A strong folder offering good protection for documents in sleeves.

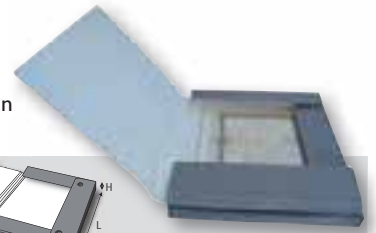

Specifications

- Acid-free
- Lignin-free
- OBA-free
- Made from CXD Premier Duo™ Archival Folding Boxboard
- Cruciform-shaped with four flaps
- Available in Premier Duo™ Grey/White

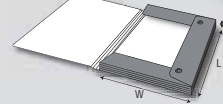

Product code	Colour	Thickness microns	Size mm L x W x H	Size inches L x W x H	Pack Qty
FDPFFF2535	Grey/White	1000	350 x 250 x 35	13 ⁵ / ₃₂ x 9 ⁷ / ₃₂ x 1 ¹ / ₈	5
FDPFFF3242	Grey/White	1000	420 x 320 x 35	16 ¹ / ₃₂ x 12 ¹⁹ / ₃₂ x 1 ¹ / ₈	5
FDPFFF4252	Grey/White	1000	520 x 420 x 35	20 ¹⁵ / ₃₂ x 16 ¹⁷ / ₃₂ x 1 ¹ / ₈	5
FDPFFF6282	Grey/White	1000	820 x 620 x 35	32 ² / ₃₂ x 24 ¹³ / ₃₂ x 1 ¹ / ₈	5

Product code	Embossed	Colour	Weight gsm/micron	Size mm	Size inches	Orientation
FDPFFF6738*	On flap	Grey/White	650mic	453 x 323 x 40	17 ¹³ / ₁₆ x 12 ¹¹ / ₁₆ x 1 ¹ / ₁₆	Landscape
FDPFFF6133	No	Duke Parchment/White	650mic	455 x 285 x 34	17 ¹⁵ / ₁₆ x 11 ¹ / ₄ x 1 ⁵ / ₁₆	Landscape
FDPFFF4092	Punched	Grey/White	300mic	340 x 215 x 40	13 ³ / ₈ x 8 ⁷ / ₁₆ x 1 ¹ / ₁₆	Portrait
FDPFFF6139	No	Grey	230gsm	354 x 234 x 20	13 ⁹ / ₁₆ x 9 ⁹ / ₁₆ x 1 ¹ / ₁₆	Portrait
FDPFFF4091	No	Grey/White	300mic	355 x 228 x 40	14 x 9 x 1 ¹ / ₁₆	Portrait
FDPFFF6782	No	Duke Parchment	230gsm	355 x 228 x 40	14 x 9 x 1 ¹ / ₁₆	Portrait

* Cambridge Newspaper System Folder

STYLE CODE HF04

Premier Duo™ pHase 3™ Folder-Box

Designed for the storage of ledgers or foolscap/folio material, these sturdy boxes are made from 1300 micron Premier Archival Folding Boxboard.

Each pHase 3™ Folder-box is creased to give the option of 3 different depths and incorporates special dust flaps which are pre-perforated to allow easy adjustment to the various depths. Each box is slotted to take 1, 2 or 3 Cotton Tying Tapes (not provided).



FDPHAS3622

Product code	Description	Key Ref	Colour	Thickness microns	Size mm L x W x H	Size inches L x W x H
FDPHAS3257	Multi-Crease - with tape slots	1PA	Grey/White	1300	356 x 229 x 38-51-64	14 x 9 x 1 ¹ / ₂ -2-2 ¹ / ₂
FDPHAS3258	Multi-Crease - with tape slots	1PB	Grey/White	1300	356 x 229 x 76-89-102	14 x 9 x 3-3 ¹ / ₂ -4
FDPHAS3259	Multi-Crease - with tape slots	1PC	Grey/White	1300	356 x 241 x 114-127-140	14 x 9 ¹ / ₂ x 4 ¹ / ₂ -5-5 ¹ / ₂
FDPHAS3620	Multi-Crease - with tape slots	A1	Grey/White	1300	381 x 254 x 38-51-64	15 x 10 x 1 ¹ / ₂ -2-2 ¹ / ₂
FDPHAS3621	Multi-Crease - with tape slots	B2	Grey/White	1300	381 x 254 x 76-89-102	15 x 10 x 3-3 ¹ / ₂ -4
FDPHAS3622	Multi-Crease - with tape slots	C1	Grey/White	1300	381 x 254 x 114-127-140	15 x 10 x 4 ¹ / ₂ -5-5 ¹ / ₂
FDPHAS3623	Multi-Crease - with tape slots	D1	Grey/White	1300	381 x 254 x 165-178-191	15 x 10 x 6 ¹ / ₂ -7-7 ¹ / ₂
FDPHAS6143	Multi-Crease - with tape slots	F1	Grey/White	1300	381 x 267 x 64-77-90	15 x 10 ¹ / ₂ x 2 ¹ / ₂ -3-3 ¹ / ₂
FDPHAS6142	Multi-Crease - with tape slots	J1	Grey/White	1300	394 x 280 x 64-77-90	15 ¹ / ₂ x 11 x 2 ¹ / ₂ -3-3 ¹ / ₂
FDPHAS3624	Multi-Crease - with tape slots	A2	Grey/White	1300	406 x 279 x 38-51-64	16 x 11 x 1 ¹ / ₂ -2-2 ¹ / ₂
FDPHAS3625	Multi-Crease - with tape slots	B2	Grey/White	1300	406 x 279 x 76-89-102	16 x 11 x 3-3 ¹ / ₂ -4
FDPHAS3626	Multi-Crease - with tape slots	C2	Grey/White	1300	406 x 279 x 114-127-140	16 x 11 x 4 ¹ / ₂ -5-5 ¹ / ₂
FDPHAS3627	Multi-Crease - with tape slots	A3	Grey/White	1300	445 x 305 x 38-51-64	17 ¹ / ₂ x 12 x 1 ¹ / ₂ -2-2 ¹ / ₂
FDPHAS3628	Multi-Crease - with tape slots	B3	Grey/White	1300	445 x 305 x 76-89-102	17 ¹ / ₂ x 12 x 3-3 ¹ / ₂ -4
FDPHAS3629	Multi-Crease - with tape slots	C3	Grey/White	1300	445 x 305 x 114-127-140	17 ¹ / ₂ x 12 x 4 ¹ / ₂ -5-5 ¹ / ₂
FDPHAS3630	Multi-Crease - with tape slots	A4	Grey/White	1300	521 x 330 x 38-51-64	20 ¹ / ₂ x 13 x 1 ¹ / ₂ -2-2 ¹ / ₂
FDPHAS3631	Multi-Crease - with tape slots	B4	Grey/White	1300	521 x 330 x 76-89-102	20 ¹ / ₂ x 13 x 3-3 ¹ / ₂ -4
FDPHAS3632	Multi-Crease - with tape slots	C4	Grey/White	1300	521 x 330 x 114-127-140	20 ¹ / ₂ x 13 x 4 ¹ / ₂ -5-5 ¹ / ₂
FDMCWR3819	School Log Book		Grey/White	650	254 x 204 x 20-30-40-52	10 x 8 ¹ / ₁₆ x 1 ¹ / ₁₆ -1 ¹ / ₁₆ -1 ¹ / ₁₆ -2 ¹ / ₁₆

We also offer pHase 3™ boxes with 'string and washer' closures - prices on application NB. Cotton tying tape not provided

STYLE CODE HF05

Premier™ Large-Flap Folders

Made from CXD Heritage Archival pHotokraft™ Paper. These large folders are made from more than one piece and are cruciform-shaped with four flaps.

Glued with specially formulated Evacon-R™ EVA adhesive.

See page 127



SMART SERVICE
custom-made folders
available for this product

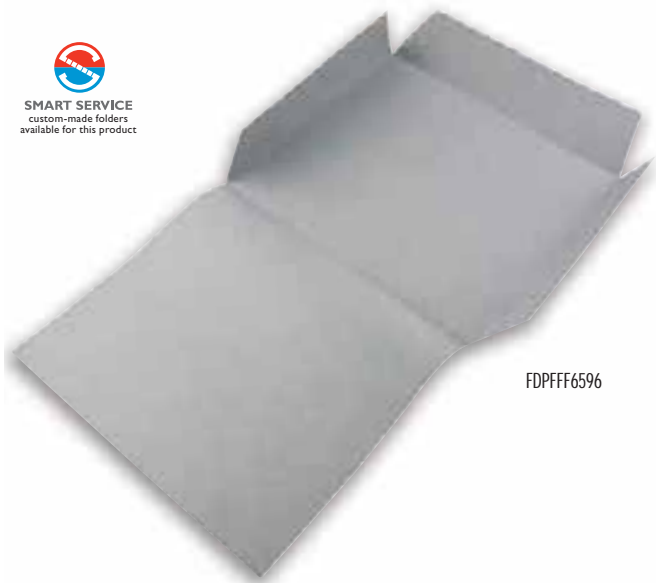

FDPFFF6596

Specifications

- Acid-free
- Lignin-free
- OBA-free
- Cruciform-shaped with four flaps
- Glued with Evacon-R™ EVA adhesive
- Available in Neutral Grey as standard



Applications

- Storage of maps, documents, prints and drawings

Heritage Archival pHotokraft™

These folders can also be supplied in any colour or weight from the Heritage Archival pHotokraft™ (HAPK) Paper range including White, Duke Parchment, Neutral Grey, Taupe and Old Grey Ivory. White also available unbuffered. Prices on application.



Product code	Description	Colour	Thickness gsm	Size mm L x W x H	Size inches L x W x H
FDPFFF6597	2 piece	Grey	350	1000 x 600	39 ³ / ₁₆ x 23 ³ / ₁₆
FDPFFF6596	2 piece	Grey	350	1000 x 700	39 ³ / ₁₆ x 27 ³ / ₁₆
FDPFFF6762	2 piece, double crease	Grey	350	1098 x 828 x 10	43 ¹ / ₄ x 32 ² / ₁₆ x ³ / ₁₆
FDPFFF6099	2 piece, double crease	Grey	350	1120 x 900 x 10	44 ¹ / ₁₆ x 35 ¹ / ₁₆ x ³ / ₁₆
FDPFFF6164	2 piece	Grey	350	1170 x 910	46 ¹ / ₁₆ x 35 ¹ / ₁₆
FDPFFF6162	2 piece	Grey	350	1219 x 864	48 x 34
FDPFFF6561	2 piece	Grey	350	1360 x 840	53 ¹ / ₁₆ x 33 ¹ / ₁₆
FDPFFF6584	Premier Four Flap Folder	Grey	350	1370 x 850 x 10	53 ¹ / ₁₆ x 33 ¹ / ₁₆ x 0 ² / ₆₄
FDPMAP6769	2 piece map folder	Grey	120	1375 x 850	54 ¹ / ₁₆ x 33 ¹ / ₁₆

STYLE CODE HF06

Premier™ Large Flap Folders One-Piece

Large Four-Flap Folder made from 230gsm Neutral Grey Heritage Archival pHotokraft Paper™. One large flap and three small flaps. Each flap has 5 creases at 5mm intervals, allowing for a depth up to 20mm.

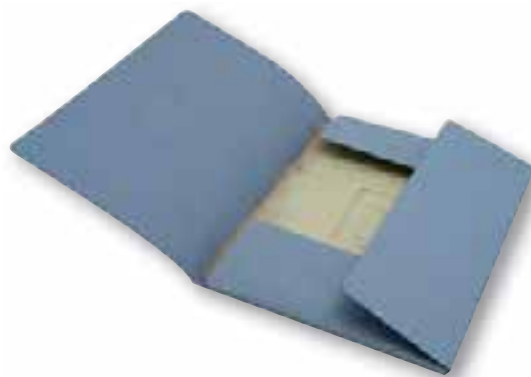

Specifications

- Acid-free
- Lignin-free
- CXD Heritage Archival pHotokraft™ (HAPK) Paper

Product code	Size mm L x W	Size inches L x W	Pack Qty
FDPFFF2332	320 x 230	12 ¹ / ₃₂ x 9 ¹ / ₁₆	25
FDPFFF3143	430 x 310	16 ³ / ₆₄ x 12 ³ / ₆₄	25
FDAFFF6848	176 x 160	6 ⁵ / ₆₄ x 6 ³ / ₆₄	

STYLE CODE HF07

Premier™ Four-Flap (Botanic Capsule) Folder

Made from CXD Heritage Archival pHotokraft™ Paper, these single-piece folders are cruciform-shaped and have four flaps. They are seamless and adhesive-free.

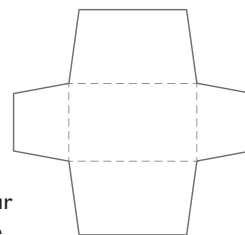

Specifications

- Acid-free
- Lignin-free
- OBA-free
- Made from CXD Heritage Archival pHotokraft™ Paper
- Cruciform-shaped with four flaps
- Available in White buffered as standard



Applications

- Collections of botanic and herbarium specimens
- Storage of documents, prints and drawings



SMART SERVICE
custom-made folders
available for this product

Product code	Colour	Weight gsm	Size mm	Size inches
FDAFFF6538	White	120	40 x 37	1 ¹ / ₁₆ x 1 ¹ / ₁₆
FDAFFF6893	White	120	40 x 40	1 ¹ / ₁₆ x 1 ¹ / ₁₆
FDAFFF6032	White	120	50 x 50	1 ¹⁵ / ₁₆ x 1 ¹⁵ / ₁₆
FDAFFF6033	White	120	76 x 51	2 x 3
FDAFFF6035	White	120	89 x 114	3 ¹ / ₂ x 4 ¹ / ₂
FDAFFF6034	White	120	95 x 70	3 ³ / ₄ x 2 ³ / ₄
FDAFFF6564	White	90	131 x 51	5 ¹ / ₁₆ x 2
FDAFFF6331	White	120	100 x 46	3 ¹⁵ / ₁₆ x 1 ¹ / ₁₆
FDAFFF6403	White	120	135 x 110	5 ¹ / ₁₆ x 4 ¹ / ₁₆
FDAFFF6220	White	120	190 x 127	7 ¹ / ₂ x 5
FDAFFF6402	White	120	205 x 75	8 ¹ / ₁₆ x 2 ⁵ / ₁₆
FDAFFF6221	White	120	254 x 178	10 x 7
FDPFFF6297	White	120	125 x 76	5 ¹ / ₁₆ x 3
FDPFFF6298	White	120	305 x 255	12 x 10 ¹ / ₁₆
FDPFFF6299	White	120	390 x 260	15 ³ / ₈ x 10 ¹ / ₄

Premier™ Four-Flap Single and Double-Crease Folders

Made from CXD Heritage Archival pHotokraft™ Paper or Premier Duo™ Archival Folding Boxboard, these single-piece folders are cruciform-shaped and some have four full-sized flaps.

Folders can also be supplied in any colour or weight from the Heritage Archival pHotokraft™ paper range including Duke Parchment, Neutral Grey, Taupe and Old Grey Ivory. Prices on application.

 *Linked Products: Cotton Tying Tapes p135; Hinged-Lid Box p22; Drop-Spine Box p11.*

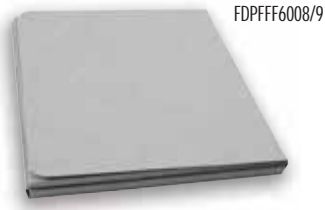

Specifications

- Acid-free
- Lignin-free
- OBA-free
- Choice of CXD Heritage Archival pHotokraft™ (HAPK) Paper or Premier Duo™ Archival Folding Boxboard
- Cruciform-shaped with four flaps
- Available in White, Grey and Grey/White



Product code	Description/ref	Colour	Weight/Thickness gsm/microns	Size mm	Size inches	Orientation
FDPFFF6008	Ai	Grey	230gsm	213 x 180 x 5	8 3/8 x 7 1/16 x 3/16	Portrait
FDPFFF6009	Aii	Grey	230gsm	213 x 180 x 10	8 3/8 x 7 1/16 x 3/8	Portrait
FDPFFF6010	Bi	Grey	230gsm	328 x 255 x 5	12 9/16 x 10 1/16 x 3/16	Portrait
FDPFFF6011	Bii	Grey	230gsm	328 x 255 x 10	12 9/16 x 10 1/16 x 3/8	Portrait
FDPFFF6012	Ci	Grey	230gsm	265 x 210 x 5	10 5/16 x 8 1/4 x 3/16	Portrait
FDPFFF6013	Cii	Grey	230gsm	265 x 210 x 10	10 5/16 x 8 1/4 x 3/8	Portrait
FDPFFF6274	Single Crease	White	230gsm	241 x 180 x 20	9 1/2 x 7 1/16 x 13/16	Portrait
FDPFFF4117	Double Crease	Grey/White	300mic	250 x 180 x 5	9 9/16 x 7 1/16 x 3/16	Portrait
FDPFFF6131		Grey	230gsm	256 x 382	10 1/16 x 15 1/16	Portrait
FDPFFF6055	Double Crease	Grey	230gsm	285 x 200 x 10	11 1/4 x 7 7/8 x 3/8	Portrait
FDPFFF6144	Double Crease with tape slots	Grey	350gsm	341 x 245 x 20	13 3/16 x 9 9/8 x 13/16	Portrait
FDPFFF6145	With tape slots	Grey	350gsm	341 x 245 x 50	13 3/16 x 9 9/8 x 1 15/16	Portrait
FDPFFF6150	Double Crease	Grey	350gsm	343 x 229 x 38	13 1/2 x 9 x 1 1/2	Portrait
FDPFFF6132		Grey/White	300mic	368 x 238	14 1/2 x 9 9/8	Portrait
FDPFFF4056	Single Crease	Grey/White	300mic	368 x 238	14 1/2 x 9 9/8	Portrait
FDPFFF6566		White	350gsm	368 x 238	14 1/2 x 9 9/8	Landscape
FDPFFF4057	Full Flaps, Double Crease	Grey	230gsm	368 x 238 x 5	14 1/2 x 9 9/8 x 3/16	Portrait
FDPFFF6135		White	230gsm	368 x 238 x 5	14 1/2 x 9 9/8 x 3/16	Portrait
FDPFFF6136	Double Crease	White	230gsm	368 x 238 x 20	14 1/2 x 9 9/8 x 13/16	Portrait
FDPFFF6056		Grey	230gsm	405 x 290 x 10	15 9/16 x 11 1/16 x 3/8	Portrait
FDPFFF6511	Double Crease	Grey	230gsm	410 x 280 x 5	16 1/8 x 11 x 3/16	Portrait
FDPFFF6006	Double Crease	Grey	230gsm	430 x 265 x 10	16 9/16 x 10 1/16 x 3/8	Portrait
FDPFFF6777		White	350gsm	430 x 310	16 9/16 x 12 2/16	Portrait
FDPFFF6667		Grey	350gsm	430 x 345 x 26	16 9/16 x 13 3/16 x 1	Portrait
FDPFFF6007	Double Crease	Grey	230gsm	550 x 435 x 10	21 3/8 x 17 1/8 x 3/8	Portrait
FDPFFF3895	Full Flaps, Single Crease	Grey	350gsm	570 x 468	22 3/16 x 18 1/16	Portrait
FDPFFF6057	Double Crease	Grey	230gsm	580 x 410 x 10	22 3/16 x 16 1/8 x 3/8	Portrait
FDPFFF6345		Grey	350gsm	680 x 440 x 10	26 3/4 x 17 1/8 x 3/8	Portrait
FDPFFF6154	1 Full and 3 Short Flaps	Grey	350gsm	855 x 600 x 10	33 3/16 x 23 3/8 x 3/8	Portrait
FDPFFF6163		Grey	350gsm	950 x 585	35 3/16 x 23 3/16	Portrait
FDPFFF6880	Premier Four Flap Folder	Grey	350gsm	368 x 238 x 5	14 1/16 x 9 9/8 x 0 9/64	Portrait
FDPFFF3972	Icelandic Parchment PX*	Grey/White	650mic	366 x 288 x 5	14 1/16 x 1 1/16 x 3/16	Portrait
FDPFFF3929	Icelandic Parchment PX*	Grey/White	650mic	366 x 288 x 10	14 1/16 x 1 1/16 x 3/8	Portrait
FDPFFF3973	Icelandic Parchment PX*	Grey/White	650mic	366 x 288 x 20	14 1/16 x 1 1/16 x 13/16	Portrait
FDPFFF4969	Icelandic Parchment P4*	Grey/White	650mic	515 x 415 x 10	20 1/4 x 16 1/8 x 3/8	Portrait
FDPFFF4970	Icelandic Parchment P4*	Grey/White	650mic	514 x 415 x 20	20 1/4 x 16 1/8 x 11 3/16	Portrait
FDPFFF6616	Premier Four Flap Folder	Grey	350gsm	690 x 430 x 26	27 1/64 x 16 59/64 x 1 1/32	Portrait
FDPFFF6893	Premier Four Flap Folder	White	120gsm	40 x 40	1 37/64 x 1 37/64	Portrait
FDPFFF8116	Premier Four Flap Folder	White	350gsm	428 x 306 x 10	16 27/32 x 12 5/64 x 0 5/64	Portrait
FDPFFF8117	Premier Four Flap Folder	White	350gsm	428 x 306 x 20	16 27/32 x 12 5/64 x 0 1/64	Portrait
FDPFFF8293	Premier Four Flap Folder	Ivory	120gsm	225 x 160	8 55/64 x 6 9/64	Portrait
FDPFFF8537	Premier Four Flap Folders	White	170gsm	370 x 255 x 15	14 3/16 x 10 3/4 x 0 9/32	Portrait
FDPFFF8563	Premier Four Flap Folder	White	230gsm	368 x 238 x 5	14 3/16 x 9 9/8 x 0 9/64	Portrait
FDPFFF8566	Premier Four Flap Folder	White	120gsm	145 x 190	5 5/64 x 7 3/64	Portrait
FDPFFF8591	Premier Four Flap Folder	Grey	120gsm	360 x 280	14 1/64 x 11 1/32	Portrait

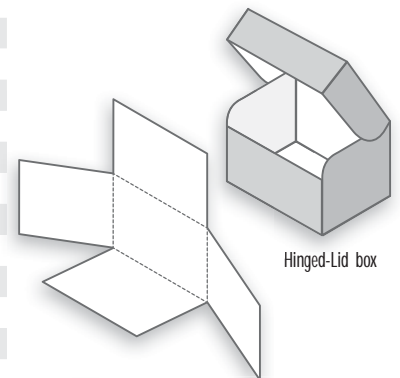

Hinged-Lid box

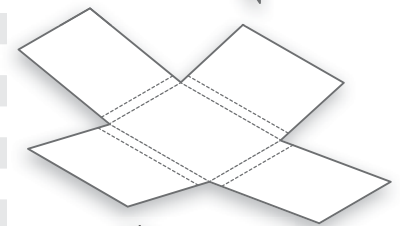

Drop-Spine box

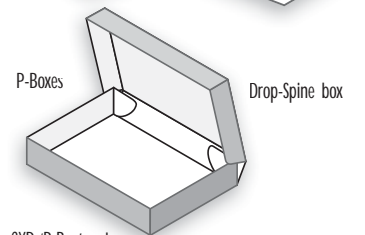

P-Boxes

CXD 'P-Box' system

* Originally designed by Nicholas Hadgraft for the storage of parchment and seals



STYLE CODE HF09

Premier Duo™ Beaux Arts, Print and Drawing Folders

Folders designed to give simple protection for single or variable amounts of prints and drawings mounted or unmounted.

Multi-creased to allow for expansion and manufactured from Premier Duo™ Archival Boxboard or Heritage Archival pHotokraft™ Paper.

Listed in imperial and royal sizes, but can be specified in other sizes to special order.

 **Linked Products:** Cotton Tying Tapes p135; Hinged-Lid Box p22; Drop-Spine Box p11.



FDPFFF4120



Product code	Description/ref	Colour	Weight/ Thickness gsm/microns	Size mm	Size inches	Orient-ation
FDPFFF4120	Beaux Arts 4-Flap	Grey	350gsm	350 x 250 x 25	13 ³ / ₄ x 9 ³ / ₁₆ x 1	Portrait
FDMCWR4030	Beaux Arts 4-Flap Royal	Grey/ White	650mic	600 x 500 x 40	23 ³ / ₈ x 19 ¹ / ₁₆ x 1 ⁵ / ₁₆	Landscape
FDMCWR4031	Beaux Arts 3-Flap Imperial	Grey/ White	650mic	800 x 650 x 40	31 ¹ / ₂ x 25 ⁵ / ₁₆ x 1 ⁵ / ₁₆	Landscape

STYLE CODE HF10

Premier™ Map Folders

Made from 120gsm Premier™ Heritage Archival pHotokraft™ (HAPK) Paper, these single-piece folders are cruciform-shaped and have one full-sized flap and three smaller flaps.

Although only 120gsm the long-fibred paper folders are resistant to tearing. This makes these folders ideal for the economic storage of large map collections.

Folders can also be supplied in any colour or weight from the Heritage Archival pHotokraft™ Paper range including Duke Parchment, Neutral Grey, Taupe and Old Grey Ivory – prices on application. Sold singly.



FDPMAP4214

Specifications

- Acid-free
- Lignin-free
- OBA-free
- Standard Colour: Grey
- Heavier weights available if required



Applications

- Storing maps and graphite works in plan chests



Product code	Description/ref	Colour	Weight/ Thickness gsm/microns	Size mm	Size inches	Orient-ation
FDPMAP4214	4-Flap Map Folder	Grey	120gsm	635 x 559	25 x 22	Portrait
FDPMAP4213	4-Flap Map Folder	Grey	120gsm	686 x 686	27 x 27	Portrait
FDPMAP4125	4-Flap Map Folder	Grey	120gsm	965 x 660	38 x 26	Portrait
FDPMAP4127	4-Flap Map Folder	Grey	120gsm	914 x 660	36 x 26	Portrait
FDPMAP4126	4-Flap Map Folder	Grey	120gsm	965 x 711	38 x 28	Portrait
FDPFFF3895	4-Flap Folder	Grey	350gsm	570 x 468 x 6	22 ¹ / ₁₆ x 18 ¹ / ₁₆ x 7 ¹ / ₁₆	Portrait
FDPFFF6345	4-Flap Folder	Grey	350gsm	680 x 440 x 10	26 ³ / ₄ x 17 ¹ / ₁₆ x 3 ⁷ / ₁₆	Portrait
FDPFFF6884	Premier Four Flap Folder	Grey/ White	1000mic	860 x 625 x 10	33 ²⁵ / ₆₄ x 24 ³ / ₆₄ x 0 ² / ₆₄	Portrait

STYLE CODE HF15

Premier Duo™ Four-Flap Folder - BT folder

Double-Crease, Four-Flap folder made from 1300 micron Premier™ Duo Grey/White heavyweight boxboard. With a double-crease on each flap allowing for a capacity of 12mm. Fitted with a Velcro® Fastener. For storage of large collections.

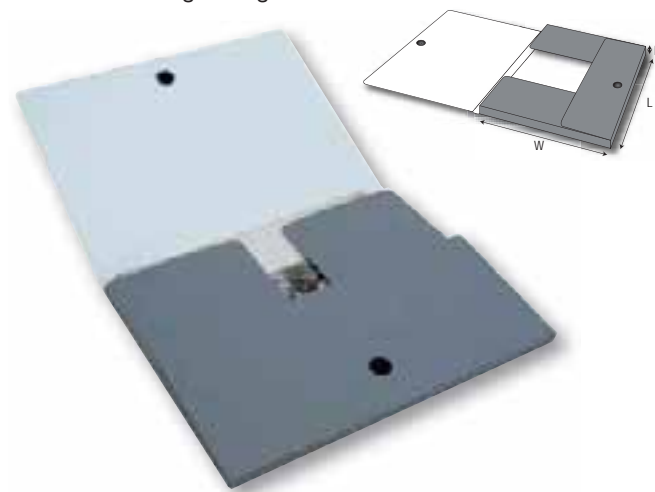

Specifications

- Acid-free
- Lignin-free
- OBA-free
- Made from CXD Premier Duo™ Archival Folding Boxboard
- Cruciform-shaped with four flaps
- Available in Premier Duo™ Neutral Grey/White

Product code	Size mm L x W x H	Size inches L x W x H	Pack qty
FDPFFF2533	330 x 250 x 15	12 ³ / ₁₆ x 9 ⁷ / ₃₂ x 0 ¹ / ₃₂	5
FDPFFF3342	420 x 320 x 15	16 ¹ / ₃₂ x 12 ¹ / ₃₂ x 1 ¹ / ₃₂	5

STYLE CODE HF16

PolypHlute™ Fluted Polypropylene Portfolio

Large PolypHlute™ Four-Flap folder fitted with Velcro® fasteners. With a capacity of 10mm. Suitable for storing prints and posters.

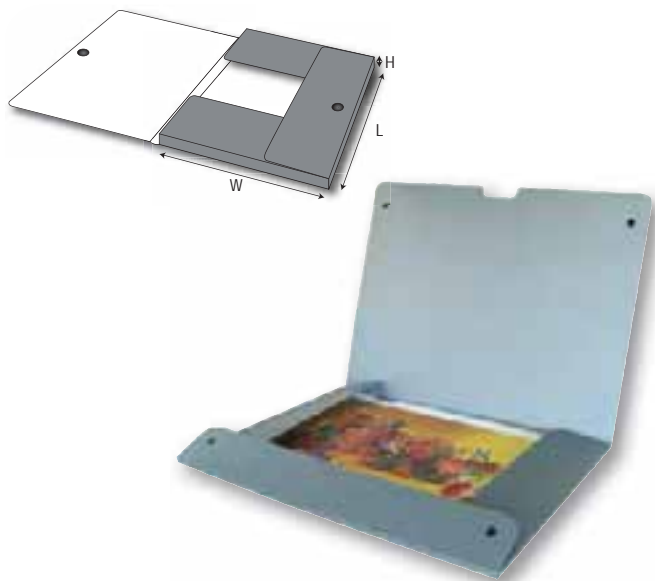

Product code	Size mm L x W x H	Size inches L x W x H	Pack qty
FDPFFF0080	850 x 640 x 10	33 ¹ / ₃₂ x 25 ¹ / ₆₄ x 2 ⁵ / ₆₄	10
FDPFFF0120	1250 x 850 x 10	49 ⁷ / ₃₂ x 33 ¹ / ₃₂ x 2 ⁵ / ₆₄	10

STYLE CODE HF11**Premier™ Western Manuscript String and Washer Folder**

Made from CXD Heritage Archival pHotokraft™ Premier 240gsm/300 micron Neutral Grey/White paper, these single-piece folders are cruciform-shaped and have four flaps. Each flap has four creases allowing for different depths and the creases are at 10mm intervals for flexibility of height. They are mostly fitted with a string and washer attachment for secure closure.

These folders can also be supplied in Duke Parchment, Old Grey/Ivory and White. Taupe colour available in 170gsm. Prices on application.

Specifications

- Acid-free
- Lignin-free
- OBA-free
- 230gsm and 300 micron
- Cruciform-shaped with four flaps
- Creased at 10mm intervals for flexibility of height
- Fitted with string and washer attachment
- Available in Neutral Grey, Neutral Grey and White



FDPWMF2253

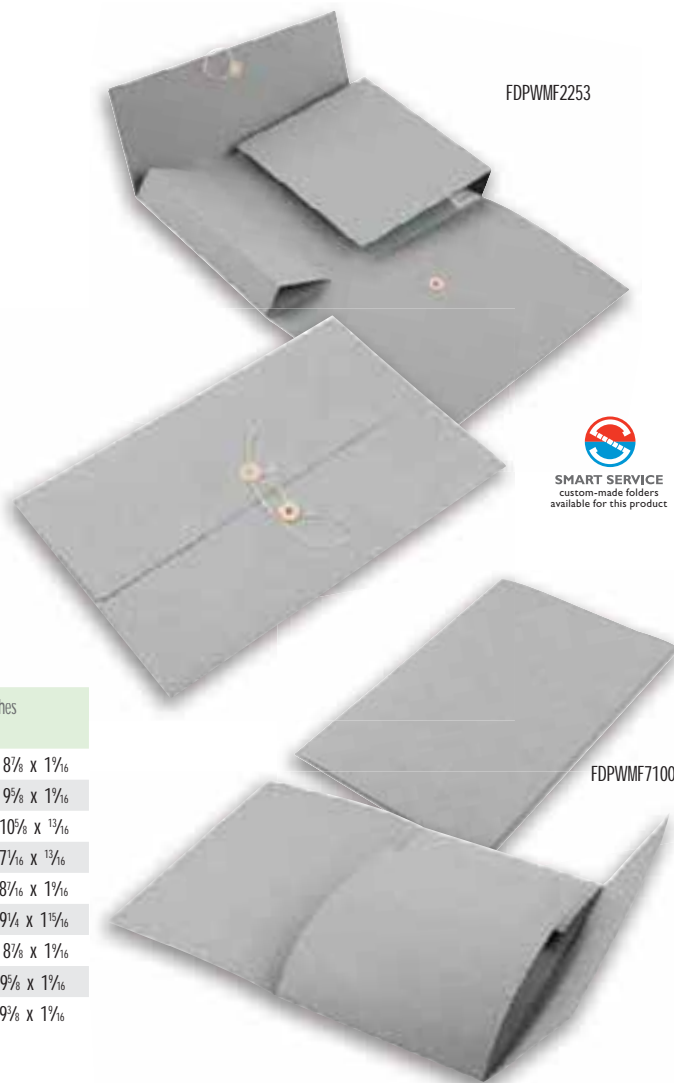

SMART SERVICE
custom-made folders
available for this product

Applications

- Safe storage of manuscripts and paper documents

Product code	Description/ref	Colour	Weight/Thickness gsm/microns	Size mm	Size inches
FDPWMF2253	4-Flap. String and Washer	Grey	230gsm	345 x 225 x 40	13 ³ / ₁₆ x 8 ⁷ / ₁₆ x 1 ¹ / ₁₆
FDPWMF2453	4-Flap. String and Washer	Grey	230gsm	345 x 245 x 40	13 ³ / ₁₆ x 9 ⁹ / ₁₆ x 1 ¹ / ₁₆
FDPWMF6134	4-Flap. String and Washer	Grey	230gsm	365 x 270 x 20	14 ¹ / ₈ x 10 ⁵ / ₈ x 1 ³ / ₁₆
FDPWMF6147	4-Flap. String and Washer	Grey	230gsm	270 x 180 x 20	10 ⁵ / ₈ x 7 ¹ / ₁₆ x 1 ³ / ₁₆
FDPWMF6545	4-Flap. String and Washer-A4	Grey	230gsm	301 x 214 x 40	11 ⁷ / ₈ x 8 ³ / ₁₆ x 1 ¹ / ₁₆
FDPWMF6730	4-Flap. String and Washer	Grey	230gsm	358 x 235 x 50	14 ¹ / ₈ x 9 ¹ / ₄ x 1 ⁵ / ₁₆
FDPWMF7091	4-Flap. String and Washer	Grey	230gsm	345 x 225 x 40	13 ³ / ₁₆ x 8 ⁷ / ₁₆ x 1 ¹ / ₁₆
FDPWMF7100	4-Flap. No attachments	Grey	230gsm	345 x 245 x 40	13 ³ / ₁₆ x 9 ⁹ / ₁₆ x 1 ¹ / ₁₆
FDPWMF3682	4-Flap. String and Washer	Grey/White	300mic	368 x 230 x 40	14 ¹ / ₂ x 9 ⁹ / ₁₆ x 1 ¹ / ₁₆

FDPWMF7100

Sold singly.

STYLE CODE HF12**Premier Duo™ Short-Flap Folder**

Made from Premier Duo™ Archival Folding Boxboard and Heritage Archival pHotokraft™ Paper, these single-piece folders are cruciform-shaped and have one large flap and three short flaps

Available as standard in 300 micron and Premier Duo™ Duplex Neutral Grey/White 650 micron. Depending on the item, they are single or double-depth-creased. Available with and without tape slots to take 13mm Cotton Tying Tapes (not provided).

Note: A maximum of four lightweight FDPSFF4881 folders will fit inside a heavyweight FDPSFF4878.

Specifications

- Acid-free
- Lignin-free
- OBA-free
- Tape slots to take 13mm Cotton Tying Tapes
- Available in Premier Duo™ Duplex Neutral Grey/White



FDPSFF6295



SMART SERVICE
custom-made folders
available for this product

Applications

- Storage of maps, documents, prints and drawings

Product code	Description/ref	Colour	Weight/Thickness gsm/microns	Size mm	Size inches	Orientation
FDPSFF6295	Foolscap/Folio - no tape slots	Grey/White	300	340 x 230 x 15	13 ³ / ₈ x 9 ¹ / ₁₆ x ³ / ₁₆	Landscape
FDPSFF4881	Foolscap/Folio	Grey/White	300	350 x 235 x 6	13 ³ / ₄ x 9 ¹ / ₄ x ¹ / ₄	Portrait
FDPSFF4878	Foolscap/Folio Multi Crease	Grey/White	650	360 x 245 x 25-13	14 ¹ / ₁₆ x 9 ⁹ / ₁₆ x 1	Portrait

FDPSFF6295



Larger sizes can be made to order using Premier Duo™ Archival Folding Boxboard or Premier Duo™ Archival Fluted Boxboard.

Also available in 230gsm or 350gsm CXD Heritage Archival pHotokraft™ Paper. Prices on application.

Linked Products: 13mm Cotton Tying Tapes p135.

STYLE CODE HF13

Premier™ Four-Flap Folders for Glass Plates

Made from 120gsm White Heritage Archival pHotokraft™ Paper. These single-piece enclosures are cruciform-shaped, have four flaps and are seamless and adhesive-free. With a depth of 3mm to accommodate a glass plate.

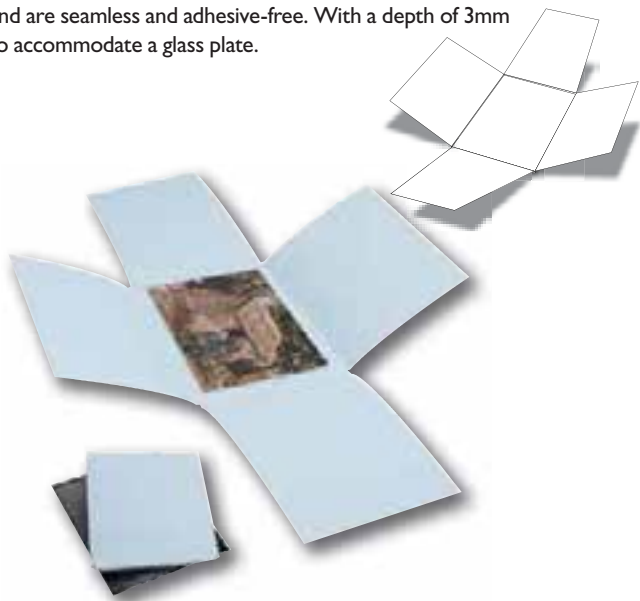

Specifications

- Acid-free
- Lignin-free
- CXD Heritage Archival pHotokraft™ (HAPK) Paper

Product code	Size mm	Size inches	Pack qty
FDPFFF0006	45 x 110	1 ⁹ / ₆₄ x 4 ² / ₆₄	50
FDPFFF0008	60 x 130	2 ³ / ₆₄ x 5 ¹ / ₈	50
FDPFFF0001	60 x 60	2 ³ / ₆₄ x 2 ³ / ₆₄	50
FDPFFF0002	60 x 90	2 ³ / ₆₄ x 3 ³ / ₆₄	50
FDPFFF0003	70 x 100	2 ⁷ / ₄ x 3 ⁵ / ₁₆	50
FDPFFF0005	80 x 105	3 ³ / ₃₂ x 4 ¹ / ₆₄	50
FDPFFF0004	80 x 80	3 ³ / ₃₂ x 3 ³ / ₃₂	50
FDPFFF0007	90 x 120	3 ⁵ / ₆₄ x 4 ²³ / ₃₂	50
FDPFFF0009	100 x 130	3 ¹⁵ / ₁₆ x 5 ¹ / ₈	50
FDPFFF0010	100 x 150	3 ¹⁵ / ₁₆ x 5 ²⁹ / ₃₂	50
FDPFFF0011	120 x 160	4 ²³ / ₃₂ x 6 ¹⁹ / ₆₄	50
FDPFFF0012	130 x 180	5 ¹ / ₈ x 7 ⁷ / ₃₂	50
FDPFFF0013	180 x 240	7 ³ / ₃₂ x 9 ²⁹ / ₆₄	50
FDPFFF0014	240 x 300	9 ²⁹ / ₆₄ x 11 ¹³ / ₁₆	50
FDPFFF0015	360 x 240	14 ¹¹ / ₆₄ x 9 ²⁹ / ₆₄	50

STYLE CODE HF14

Premier Duo™ Four-Flap Folder - PR folder

Double-Crease, Four-Flap folder with an inner four-flap folder, allowing a depth of 4mm.

The outer folder is made from 1000 micron Premier Duo™ Grey/White heavyweight boxboard.

The inner folder is made from 170gsm Heritage Archival pHotokraft™ Paper. For storage of manuscripts.

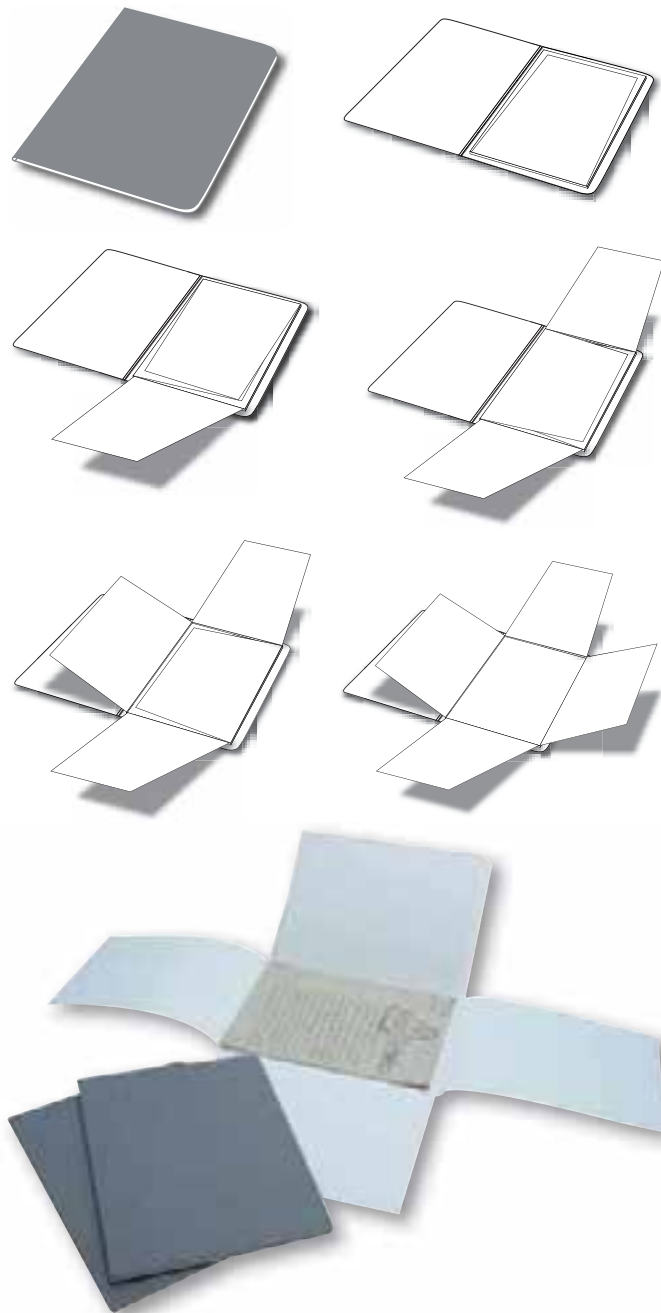

Specifications

- Acid-free
- Lignin-free
- OBA-free
- Inner folder - CXD Heritage Archival pHotokraft™ (HAPK) Paper and outer folder - Premier Duo™ Archival Folding Boxboard
- Cruciform-shaped with four flaps

Product code	Internal Size mm L x W	Internal Size inches L x W	External Size mm L x W	External Size inches L x W	Pack qty
FDPFFF1925	180 x 240	7 ³ / ₃₂ x 9 ²⁹ / ₆₄	195 x 255	7 ¹⁵ / ₆₄ x 10 ¹ / ₆₄	5
FDPFFF2531	240 x 300	9 ²⁹ / ₆₄ x 11 ¹³ / ₁₆	255 x 315	10 ¹ / ₆₄ x 12 ¹⁹ / ₃₂	5
FDPFFF3725	240 x 360	9 ²⁹ / ₆₄ x 14 ¹¹ / ₆₄	255 x 375	10 ¹ / ₆₄ x 14 ⁹ / ₆₄	5

Premier Duo™ Traditional Uncovered Portfolios

Handmade, artists' style portfolios without cloth covering. They are made from 1300 and 1625 micron Grey/White, Premier Duo™ Archival Folding Boxboard with 25mm capacity Black Library Buckram spines lined with White Heritage Archival pHotokraft™ (HAPK) Paper. They have three 230gsm HAPK inner flaps of matching capacity and are secured by Black cotton ties.

Product Code	Type	Size mm	Size inches	Pack qty
FDPDTP8512	A0	1220 x 850	48 ¹ / ₂ x 33 ¹ / ₂	5
FDPDTP6187	A1	876 x 610	34 ³ / ₄ x 24 ¹ / ₄	5
FDPDTP4461	A2	610 x 440	24 ¹ / ₄ x 17 ¹ / ₄	5
FDPDTP3244	A3	440 x 320	17 ¹ / ₄ x 12 ¹ / ₂	5
FDPDTP2432	A4	320 x 240	12 ¹ / ₂ x 9 ³ / ₄	5
FDPDTP6652		660 x 521	26 x 20 ¹ / ₂	5
FDPDTP7857		787 x 572	31 x 22 ¹ / ₂	5



STYLE CODE FF01

Premier™ Open-Top Expansion Wallets/Pockets Adhesive Flap

Premier expanded gusseted wallet in grey. Made from 120gsm White Heritage Archival pHotokraft™ Paper.



Specifications

- Acid-free
- Lignin-free
- CXD Heritage Archival pHotokraft™ (HAPK) Paper

Product Code	Description	Weight gsm	Size mm	Size inches	Colour
FDAWNF3279	No Flap, with gusset. Landscape	120	345 x 229 x 25	13 ³ / ₄ x 9 ¹ / ₄ x 0 ⁶ / ₄	Neutral Grey
FDAWNF3821	No Flap, with gusset. Portrait	230	341 x 225 x 40	13 ³ / ₄ x 8 ⁵ / ₄ x 1 ³ / ₄	Neutral Grey
FDAWNF4941	No Flap, with gusset. Landscape	120	345 x 229 x 50	13 ³ / ₄ x 9 ¹ / ₄ x 1 ³ / ₂	Neutral Grey
FDAWNF6149	No Flap, with gusset	230	350 x 254 x 100	13 ⁵ / ₂ x 10 x 3 ¹ / ₁₆	Neutral Grey
FDAWNF6344	No Flap, with gusset. Portrait	230	315 x 408 x 35	12 ¹ / ₂ x 16 ¹ / ₁₆ x 1 ³ / ₁₆	Neutral Grey
FDAWNF6548	No Flap, with gusset. Landscape	120	370 x 260 x 25	14 ⁴ / ₁₆ x 10 ¹ / ₄ x 0 ⁶ / ₄	Neutral Grey
FDAWNF6641	Gusset, no flap. Landscape	120	327 x 230 x 40	12 ¹ / ₈ x 9 ¹ / ₁₆ x 1 ³ / ₄	Neutral Grey
FDAWNF6668	No flap	230	260 x 260 x 26	10 ¹ / ₄ x 10 ¹ / ₄ x 1 ³ / ₂	Neutral Grey

pHoton™

High-purity photographic storage products for delicate photographic glass plates, negatives and prints



The pHoton™ system includes a specially developed range of papers, folders, envelopes and pockets created from 100% cotton, unbuffered, high-purity, silver-image-safe paper.

About pHoton™

Conservation By Design classify pHoton™ as 'high-purity' to distinguish between it and ordinary acid-free paper. pHoton™ is produced to a fixed quality standard for CXD by the Munktel Mill, founded in 1740 and the world's first maker of chromatography and filter paper.

pHoton™ is made on a machine that is one metre wide which only produces white paper in qualities designed for specialist filtration, medical, conservation and scientific uses.

Converted products include:

- pHoton™ folder for prints and document storage.
- pHoton™ Four-Flap Enclosure for glass plates.
- pHoton™ Sleeves and Pockets 'Stitch in Timecare®' for the storage of negative film. Tailored to meet most common sizes: 35mm, 60mm and 70mm film. Sleeves are sewn with cotton thread to guarantee that nothing can accelerate the ageing of the film.

The porous nature of the paper prevents the build up of harmful gases within the enclosures which can happen with less porous storage papers and plastic enclosures.

pHoton™ High-Purity Papers

These 100% cotton, high-purity, silver-image-safe papers and photographic storage products are produced for CXD at the Munktel paper mill which is famous for the production of the world's first filter paper. They have been developed in collaboration with leading photographic conservators and institutes of conservation.

The pHoton™ range consists of papers made from un-sized pure cotton fibres which are virtually 100% pure alpha cellulose containing no chemicals whatsoever and, because of this, they are probably the purest of all photographic storage papers.

They are un-calendered to allow maximum airflow and prevent any potentially harmful build up of gases that may be emitted by the photographic material stored within the enclosure. Due to their purity and porosity, these papers can be used safely for long-term storage of all kinds of photographic materials be they negatives or prints and irrespective of the photographic technique used to create them. They can, of course, be used for storing any object requiring a non-alkaline paper.

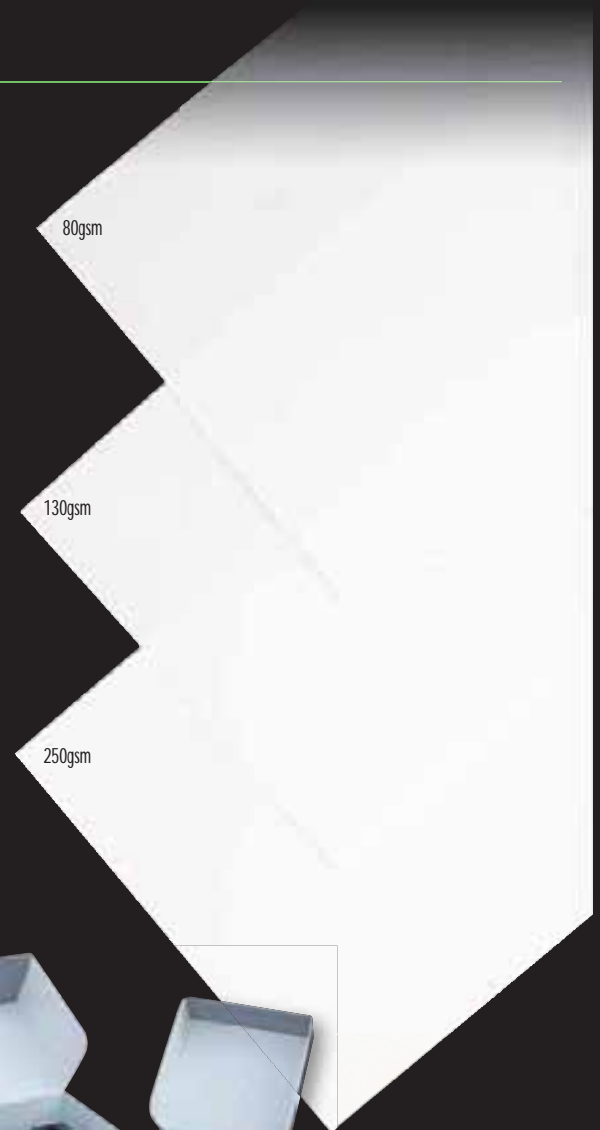

Glass plate negative boxes: example shown of option with Plastazote® CXD Channel Panels to hold negatives vertically within a pHoton™ four-flap folder.

For full details on pHoton™ see Papers section p63 and p88.





pHoton™ Four-Flap Enclosures for Glass Plate and Film Negatives

Made from 80gsm CXD pHoton™ paper the single-piece, die-cut enclosures are cruciform-shaped, have four flaps and are seamless and adhesive-free, for the storage of photographic glass plates.

These enclosures are available in most common glass plate sizes. Photographic glass plates can be stored safely with no risk of pressure marks. They can also be viewed without being removed from their protective coating by just unfolding the flaps and leaving the plate untouched, safely on a flat surface e.g. a light box. The same enclosures can also be used for the storage of film negatives or prints.

Four-flap enclosures normally generate a lot of wastage because their cruciform shape means that half the paper area required to make them gets thrown in the waste bin. Generally the manufacture of four flaps is carried out as a post-mill operation by paper converters, but with pHoton™ Four Flaps, all the conversion is carried out within the paper mill and all the wastage is recycled. This makes both ecological and economical sense, as customers are only charged for the paper received.

Specifications

- pH6.7
 - Acid-free
 - High-purity, chromatography-grade
 - 100% cotton fibre from pure cotton linters
 - Passes ANSI Photography Activity Test (PAT) IT9.2 (ISO 10214)
 - Un-sized
 - Unbuffered
 - Un-calendered surface to allow maximum airflow
 - Passes Silver Tarnish Test
 - Special sizes and designs can be made to order
 - Available as standard in White 80gsm with other weights available on request
- For full pHoton™ specification see p88



Applications

- Storage of photographic glass plates and film negatives

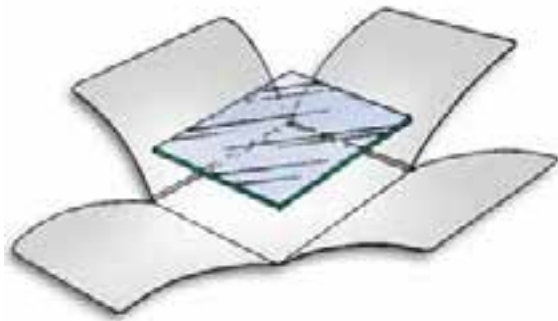

 **Linked Products:** Premier Duo™ Hinged-Lid and Drop-Spine Boxes p11 and p22; Channel Panel p120; Light Sheet p222.

Product code	T*	Description	Plate size inches	Size mm	Size inches	Pack Qty
PHFFEN4007		Daguerreotype Traditional Sixteenth Plate		37 x 43	1 1/16 x 1 1/16	200
PHFFEN4461				45 x 45	1 13/16 x 1 13/16	200
PHFFEN4462				45 x 60	1 13/16 x 2 1/8	200
PHFFEN4488				45 x 110	1 13/16 x 4 1/16	200
PHFFEN4485				50 x 100	1 13/16 x 3 15/16	200
PHFFEN4006		Daguerreotype Traditional ninth plate	2 x 2 1/2	52 x 65	2 1/16 x 2 1/8	200
PHFFEN4465				60 x 60	2 3/8 x 2 3/8	200
PHFFEN4497				60 x 90	2 3/8 x 3 3/16	200
PHFFEN4491				60 x 130	2 3/8 x 5 1/8	200
PHFFEN4474		English	2 1/2 x 3 1/2	65 x 90	2 1/16 x 3 3/16	200
PHFFEN4005		Daguerreotype Traditional sixth plate	2 3/4 x 3 3/4	71 x 84	2 13/16 x 3 1/16	200
PHFFEN4463				80 x 90	3 1/16 x 3 3/16	200
PHFFEN4489		English Lantern	3 1/4 x 3 1/4	84 x 84	3 1/16 x 3 1/16	200
PHFFEN4455				84 x 99	3 1/16 x 7 1/8	200
PHFFEN4500		Daguerreotype Traditional quarter plate	3 1/4 x 4 1/4	84 x 110	3 1/16 x 4 1/16	200
PHFFEN4477	T	Daguerreotype Traditional quarter plate	3 1/4 x 4 1/4	84 x 110	3 1/16 x 4 1/16	200
PHFFEN4456		Daguerreotype Traditional quarter plate	3 1/4 x 4 1/4	84 x 110	3 1/16 x 4 1/16	100
PHFFEN4481				84 x 217	3 1/16 x 8 1/2	200
PHFFEN4501			3 1/2 x 4 1/16	90 x 120	3 1/16 x 4 3/4	200
PHFFEN4458			3 1/2 x 4 1/16	90 x 120	3 1/16 x 4 3/4	100
PHFFEN4494		English, European, USA Lantern	3 1/2 x 3 1/2	91 x 91	3 1/16 x 3 1/16	200
PHFFEN4009	T	English, European, USA Lantern	3 1/16 x 3 1/16	91 x 91	3 1/16 x 3 1/16	200
PHFFEN4008		American Lantern diapositive	3 1/2 x 4	91 x 103	3 1/16 x 4 1/16	200
PHFFEN4482			3 1/2 x 5 1/2	91 x 141	3 1/2 x 5 1/2	200
PHFFEN4511			3 1/16 x 5 15/16	100 x 150	4 x 6	200
PHFFEN4487		English	4 x 5	103 x 129	4 1/16 x 5 1/16	200
PHFFEN4472				115 x 155	4 1/2 x 6 1/10	200
PHFFEN4484		Daguerreotype Traditional half plate	4 1/2 x 5 1/2	116 x 141	4 1/16 x 5 1/16	200
PHFFEN4493				120 x 230	4 3/4 x 9 1/8	200
PHFFEN4499		English non standard half plate	4 3/4 x 6 1/2	122 x 167	4 13/16 x 6 1/16	200
PHFFEN4476	T	English non standard half plate	4 3/4 x 6 1/2	122 x 167	4 13/16 x 6 1/16	200
PHFFEN4457		English non standard half plate	4 3/4 x 6 1/2	122 x 167	4 13/16 x 6 1/16	100
PHFFEN4460				122 x 180	4 13/16 x 7 1/8	200
PHFFEN4502		English	5 x 7	130 x 180	5 1/8 x 7 1/8	200
PHFFEN4459		English	5 x 7	130 x 180	5 1/8 x 7 1/8	100
PHFFEN4022		Astronomical	6 1/2 x 6 1/8	167 x 160	6 1/16 x 6 1/16	200
PHFFEN4503			7 1/16 x 9 1/16	180 x 240	7 1/8 x 9 1/2	200
PHFFEN4498		Daguerreotype Traditional whole plate	8 1/2 x 6 1/2	218 x 167	8 1/16 x 6 1/16	200
PHFFEN4475	T	Daguerreotype Traditional whole plate	8 1/2 x 6 1/2	218 x 167	8 1/16 x 6 1/16	200
PHFFEN4480		1 x extra short flap		204 x 254	8 1/32 x 10	200
PHFFEN4021		Astronomical	8 x 7	205 x 180	8 1/16 x 7 1/16	200
PHFFEN4490		Daguerreotype Traditional full plate	8 x 10	205 x 255	8 1/16 x 10 1/16	200
PHFFEN4492		English and Astronomical		210 x 210	8 1/4 x 8 1/4	200
PHFFEN4483		Daguerreotype full plate	8 3/4 x 10 1/2	210 x 270	8 1/4 x 10 5/8	200
PHFFEN4002		Daguerreotype Traditional double whole plate	8 1/2 x 13	217 x 332	8 1/16 x 13 1/16	200
PHFFEN4466		Short sides		240 x 300	9 1/16 x 11 13/16	200
PHFFEN4486		Four full flaps		240 x 300	9 1/16 x 11 13/16	200
PHFFEN4514		One short flap		240 x 300	9 1/16 x 11 13/16	200
PHFFEN4479		90° flaps short, 1 extra short flap		254 x 305	10 x 12	100
PHFFEN4020		Astronomical	10 1/2 x 10 1/2	268 x 268	10 13/16 x 10 13/16	200
PHFFEN4478		Short flaps		300 x 320	11 13/16 x 12 1/16	200
PHFFEN4496		2 full flaps and 2 three-quarter flaps	12 x 10	306 x 256	12 1/16 x 10 1/16	200
PHFFEN4473	T	4 full flaps, 8mm tab on one long side	12 x 15	305 x 381	12 x 15	100
PHFFEN4019		Astronomical	12 x 10	306 x 306	12 1/16 x 12 1/16	200
PHFFEN4001	T	1 side 10mm longer, 2 sides short	12 x 10	307 x 256	12 1/8 x 10 1/16	200
PHFFEN4467		1 side short		300 x 400	11 13/16 x 15 3/4	200
PHFFEN4018		Astronomical (common)	15 x 15	383 x 383	15 1/16 x 15 1/16	200
PHFFEN4468		3 sides short		500 x 600	19 3/4 x 23 3/8	200
PHFFEN7502		2 short sides	7 1/8 x 9 1/2	180 x 240	7 1/8 x 9 1/2	200

*T = Top Index Tab

Daguerreotypes, Astronomical, English and American Lantern, and additional English glass plate sizes, courtesy of The Centre for Photographic Conservation, London SE23
Reference: The Imperfect Image - Ian L Moor and Angela Moor
Special custom-made sizes can be made to order.



Four-Flap Enclosures

Four-Flap Folders



PHFFEN4455



PHPHFF0510



These form part of the CXD 'P-Box' mounting and storage system including *pHoton™* papers and folders.

All available to suit each size of CXD Premier Duo™ 'P-Boxes'.

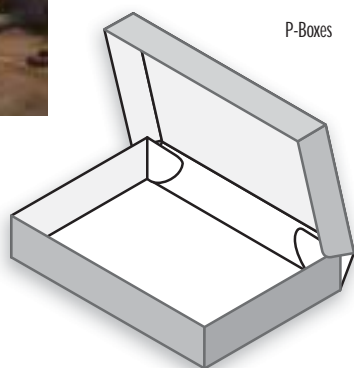

P-Boxes

Munktel specialist high-purity paper machine only one metre wide

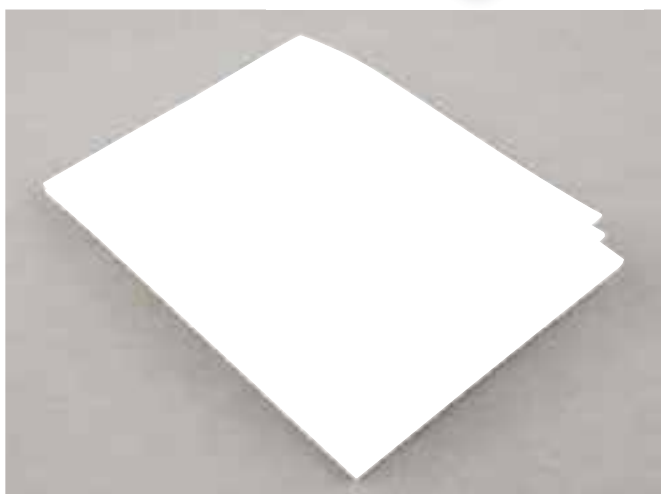

Specifications (see previous page for full details)

- Un-sized
- Glued with specially formulated Evacon-R™ conservation adhesive
- Available in White - 80gsm



STYLE CODE HF41

pHoton™ Photographic Print Four-Flap Folder



The *pHoton™* folders are designed to fit comfortably within the range of Premier Duo™ drop-spine photograph boxes.

The folders are made from *pHoton™* 250gsm paper and there are *pHoton™* mounting and separator sheets available to fit these folders. The mounting sheets fit neatly inside the die-cut folders and are also made from *pHoton™* 250gsm.

Part of the 'P-Box' and folder system.

The separating/interleaving sheets are made in the lighter weight *pHoton™* 80gsm.

 **Linked Products:** Premier Duo™ Hinged-Lid and Drop-Spine Boxes p11 and p22; Premier Duo™ Photographic Boxes p12; *pHoton™* Paper p63 and 88; *pHoton™* Separator Sheets p88; *pHoton™* Mounting Sheets p88.

Applications

- Photographic print and negative storage

Product code	Ref	Colour	Weight gsm	Size mm	Size inches	Pack Qty
PHPHFF0510	P0	White	250	184 x 133 x 5	7¼ x 5¼ x ¾	50
PHPHFF0511	PZ	White	250	244 x 184 x 5	9½ x 7¼ x ¾	50
PHPHFF0512	P1	White	250	257 x 207 x 5	10½ x 8½ x ¾	50
PHPHFF0513	A4F	White	250	301 x 220 x 5	12 x 8¾ x ¾	50
PHPHFF0514	P2	White	250	308 x 257 x 5	12½ x 10½ x ¾	50
PHPHFF0515	PX	White	250	359 x 283 x 5	14½ x 11½ x ¾	50
PHPHFF0516	P3	White	250	410 x 308 x 5	16½ x 12½ x ¾	50
PHPHFF0517	P4	White	250	511 x 410 x 5	20½ x 16½ x ¾	50
PHPHFF0518	P5	White	250	613 x 511 x 5	24½ x 20½ x ¾	50

Part of the *pHoton™* Archival 'P-Box' and Folder System.

STYLE CODE CF40

pHoton™ 100% Cotton Envelope



Made from 80gsm *pHoton™* high-purity 100% cotton paper which is un-sized and very low in calcium carbonate and other trace elements with a pH of 6.7. These die-cut envelopes are glued with specially formulated Evacon-R™ conservation adhesive, opening on one narrow edge. Without flap or gusset unless specified.

Only the ANE22 coin envelope is supplied with a cover flap.

Applications

- Photographic negatives, glass plates, land plates and coins

Product code	Type	Style Ref	Colour	Weight gsm	Size mm	Size inches
FDCPNE8022	Coins (with 20mm flap)	ANE22	White	80	51 x 51	2 x 2
FDCPNE8023	60 x 80mm negatives	ANE23	White	80	64 x 89	2½ x 3½
FDCPNE8045	4" x 5" negatives	ANE45	White	80	111 x 137	4½ x 5½
FDCPNE8034	Single 120mm negatives	ANE34C	White	80	76 x 114	2¾ x 4¾
FDCPNE8046	4" x 6" negatives	ANE46B	White	80	156 x 107	6½ x 4½
FDCPNE8056	4¾" x 6½" plates	ANE56	White	80	127 x 172	5 x 6¾
FDCPNE8057	5" x 7" plates Portrait	ANE57	White	80	137 x 187	5½ x 7½
FDCPNE8068	Whole plate negatives	ANE68	White	80	172 x 222	6¾ x 8¾
FDCPNE8081	8" x 10" negatives	ANE810	White	80	216 x 267	8½ x 10½
FDCPNE8021	35mm film negatives	ANE210	White	80	64 x 273	2½ x 10¾
FDCPNE8010	10" x 12" plates	ANE1012	White	80	260 x 311	10¼ x 12¼
FDCPNE8011	11" x 14" land plates	ANE1114	White	80	292 x 368	11½ x 14½

All in packs of 25

STYLE CODE DF01 + DF40



pHoton™ Timelock™ Adhesive-Free Negative Envelopes and Pockets

pHoton™ Timelocks™ are made from 80gsm pHoton™ high-purity 100% cotton unbuffered paper and have been designed to avoid the use of any adhesives to ensure the absolute safety of photographic negative masters that do not require frequent handling. They are meant for the long-term storage of the most precious and sensitive of photographic archive material such as microfiche masters. The utmost caution has to be taken against degradation from contact with potentially harmful elements such as adhesives that may in time react with the enclosed material. Eliminating the gluing process makes pHoton™ Timelocks™ envelopes safer and better value than conventional envelopes.

Linked Products: Planorama® Drawers p233; CXD Cold Storage p230.

Specification

• For full specification see pHoton™ paper section p88



Applications

• Absolute safety of photographic negative masters that do not require frequent handling.

Product code	Use	Colour	Weight gm ²	Size mm	Size inches	Pack Qty
PHTLOK6617	Microfiche	White	80	152 x 107	6 x 4 ¹ / ₁₆	200
PHTLOK6616	5" x 4" negatives	White	80	129 x 105	5 ¹ / ₁₆ x 4 ¹ / ₁₆	200
PHTLOK6615	35mm film negatives	White	80	250 x 45	9 ³ / ₁₆ x 1 ³ / ₄	200
PHTLOK4551	70mm film negatives	White	80	257 x 70	10 ¹ / ₈ x 2 ³ / ₄	200

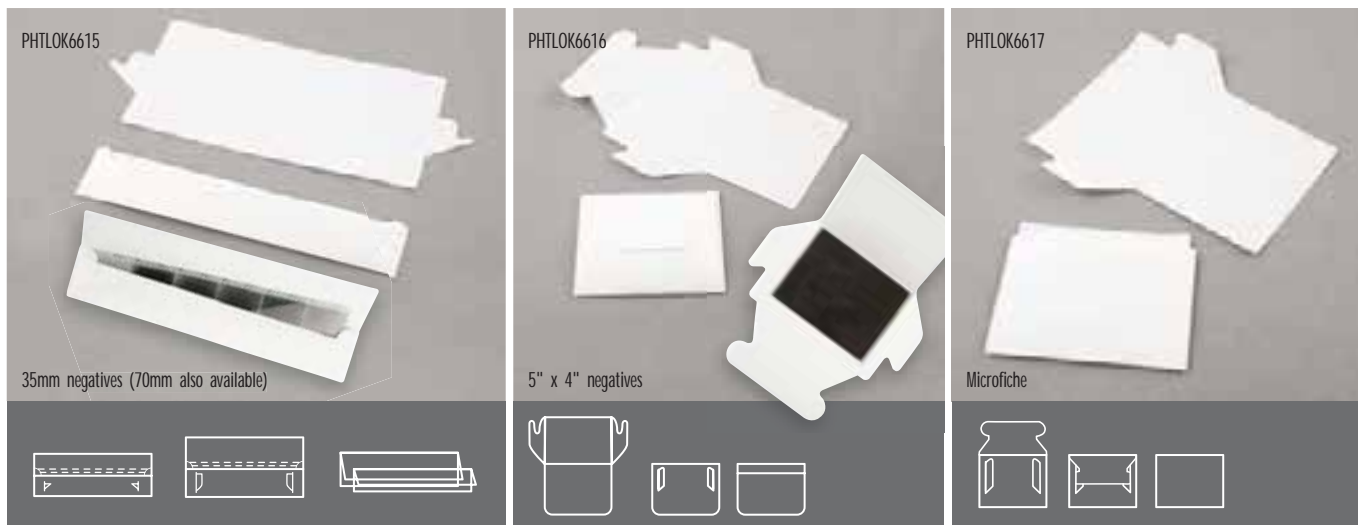

Photographic Storage

CXD Cold Storage for vulnerable photographic collections

- Still images or motion pictures
- Film typically requiring cold storage:
- Cellulose nitrate film negatives
- Cellulose acetate film negatives, 'safety film'
- Dye-based colour material



Conservation By Design Limited (CXD) has brought together selected individuals with specific photographic conservation and refrigeration expertise to complement the conservation storage expertise of CXD to provide bespoke integrated cold storage solutions for the conservation market. Modern synthetic materials are degrading at an ever-increasing rate and cold storage is now widely accepted as being the best way of preserving photographic and special museum collections for future generations.

For more detailed information go to Equipment section p122. Also see Conservation Storage, Workshop and Display Storage section p232.

Planorama® storage systems



Planorama® is a unique system of aluminium archival cabinets and storage drawers. Planorama® is a combination of imagination, style and function designed to solve problems.

If it can be imagined it can probably be made.

- Lightweight
- Big Drawers
- Slim Drawers
- Deep Drawers
- Display Drawers
- Framed Drawers
- Showcase Drawers and Tops



10mm drawer in a small module to house a photographic collection

Transparent Storage

Plastic enclosures for conservation storage.

Because of their transparency plastics are commonly used for the protection of archival documents and photographs. However, many of the first plastics used were later found to be harmful to the objects they enclosed. The most common plastic used was PVC (polyvinyl chloride).

It has good transparency and can be welded with ease. The problem was that it contained a large amount of plasticiser to keep it flexible. In time this plasticiser comes to the surface and transfers a sticky, acidic residue to the enclosed object. Plasticisers are not the only danger from poor quality plastics. Polypropylene is often recycled and can have fatty acid slip coatings to make it run smoother on production machinery.

Polypropylene, Polyethylene and Complex Plastics

Only virgin polypropylene without this slip coating should be used for photographs or archival material. Virgin polyethylene, without plasticisers or harmful additives that might off-gas, is suitable for archival storage but it lacks rigidity and clarity. When applied as a thin film to polyester it gains strength and rigidity but the crystal-like transparency is reduced. The recent inclusion of reactive copper and carbon particles in polyethylene and other plastics offers new possibilities for the long-term protection of archival material. This is also the case with multi-layer oxygen and moisture-barrier films designed for use with vacuum, inert gas purging or oxygen-scavengers, all of which can slow down the rate of deterioration of a variety of sensitive materials.

The Timecare® Polyester HCL (High Clarity Laminate) Album Pages, developed for the popular Timecare® Ringbinder Boxes, utilise a combination of the strength and durability of polyester with the ease of welding of polyethylene. Album pages made solely from polyethylene or polypropylene, although cheaper in material and production costs, do not offer the same level of strength or protection against fire in a disaster scenario.

The same multi-layer technology employed by the HCL album pages is used for the oxygen and moisture-barrier films and pouches listed in this catalogue. These products allow visible storage in a controlled atmosphere with the absence of oxygen; achieved by gas-flushing or oxygen-scavengers using nanotechnology.

Heavyweight, matt polypropylene is an excellent material for making large drawer files. The matt surface is non-reflective and has reduced surface contact with the contents. It can be welded or sewn as with our Visifile™ folders. In use, it makes an almost indestructible folder that allows the contents to be seen at a glance.

Polyester

Polyester is known as the most stable and chemically inert plastic used for conservation storage. It offers optical clarity, strength, rigidity and a surface free of slip coatings.

Melinex® and Mylar® are the most commonly known brands of polyester. The clarity, purity and resistance to degradation is prized by conservators, however it is much harder to weld and form into pockets and complex album pages than softer plastics such as polyethylene and polypropylene, which have a lower melting temperature. Regular polyester, which we are calling Crystal Type I, can be welded with heat but the fusion temperature band is very narrow, meaning too much heat and it will crystallise, too little and it will not weld. Edge-welding machines, which apply heat to the edges of two sheets of type I polyester, have been developed which cause the polyester to retreat and melt together forming a small raised bead around the edge of a pocket. This technology is only suitable for simple pockets or sleeves. For more complex tasks, requiring subdivisions or spot-welding away from the edges, ultrasonic welding technology is required. The equipment is rather pricey but can be used for edge-welding, cross-welding and spot-welding of standard Crystal Polyester Type I. Timecare® Crystal Polyester Type I Album Pages are made using a combination of bead and ultrasonic welding. Impulse heat-welding equipment can be used to weld type I polyester but can be difficult owing to the narrow weld-temperature band. Bead-welders, Impulse-welders and Ultrasonic welders are listed in the equipment section of this catalogue. Timecare® Crystal Polyester Type I storage pockets/enclosures are edge-welded in our production facility using the bead-welding process similar to the 'Original Curateur™' polyester welder machine supplied by Conservation By Design.

To address the difficulties in welding Standard Polyester Type 1, Conservation By Design have introduced a completely new, pure polyester. It is sold under the brand name Timecare® Crystal Polyester Type 2. This new material has a wider fusion band and can be welded at a lower temperature. This means that it can be spot-welded with a tacking iron, edge-welded with the CXD Curateur Welder or edge and cross-welded with the CXD Criss Cross impulse sealer. Type 2 polyester is easier to weld to paper, board, polyethylene and non-woven polyester material than regular Type 1 polyester, thereby opening up new possibilities for conservators unable to afford expensive ultrasonic welding equipment.

The new Timecare® Crystal Polyester Type 2 Album Pages have been developed from this material and meet demands for an even higher clarity alternative to the Timecare® HCL Album Pages. They are made from 100-micron material compared to the 75-micron used for the HCL pages. Crystal Type 2 Polyester has a closer surface contact and a higher static cling than the HCL Laminate Polyester, which has led to the introduction of album pages with two adjacent sides open to facilitate the insertion of lightweight or delicate items. Timecare® Crystal Type 2 Album Pages are available in a full range of sizes.

Controlling the atmosphere or environment is crucial for good storage of all kinds of material, but photographs are particularly sensitive to humidity. A stable relative humidity (RH) should be sought to avoid fluctuations that can cause cracking of surface coatings. Photographs generally require around 40% RH and 55% RH is recommended for other paper-based items. If the RH exceeds 65% and it fluctuates, there is a danger of 'Ferrotyping' or adhesion of the photographic surface to the plastic enclosure caused by condensation.

For the professional archive, Conservation By Design offer an integrated temperature and humidity 'room within a room' system which is modular and can be tailored to the size of the space available, no matter how big. For the smaller user, De-humidifiers, ProSorb™ and Silica Gel are available and, although they are no substitute for a well-controlled environment, good quality, acid-free boxes offer a low-cost 'buffer' against fluctuations in temperature and humidity.



FDSTDP series
Timecare® Storage and Display Folder

i Information

- Polyester has a higher melt temperature than polypropylene or polyethylene, and will give better protection in the event of fire.
- Chalk, charcoal and art mediums/text with poorly fixed surfaces (this may include some damaged photo-images) *should not* be stored in plastic enclosures, because any static charge in the plastic will remove particles from the surface of the object.
- Degrading nitrate and cellulose acetate negatives *should not* be stored in plastic enclosures, because harmful gases will be trapped inside the enclosure. pHoton™ paper enclosures offer a more stable solution for this type of material because of its porosity.

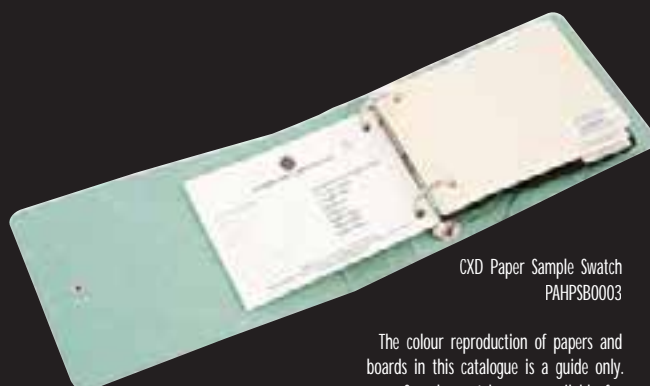

CXD Paper Sample Swatch
PAHPSB0003

The colour reproduction of papers and boards in this catalogue is a guide only. Sample swatches are available for colour-matching purposes from CXD.

Polyester Album Pages

Timecare® Crystal Polyester Type 2: Album Pages – A4

Timecare® Crystal Polyester Type 2 Album Pages are for those looking for optimal clarity and strength for long-term, conservation-grade storage and display of photographs, documents and ephemera. The ultra-smooth surface of the material creates intimate contact which makes these so useful for photographic storage – can also make insertion of thinner papers difficult on larger pockets.

To make inserting thinner papers easier, a new album page style has been developed, called L-style where pockets are open on two adjacent sides. In CXD tests with several pieces of paper in each pocket, documents have been held securely in position because of the hold gained through intimate contact between the smooth polyester and paper surfaces.

These products, developed and manufactured by Conservation By Design, are made from 100-micron, crystal clear, PAT-approved, CXD polyester type 2, offering greater rigidity and clarity than the existing HCL range of album pages. They have a binder edge (25mm), with 4 holes punched at 80mm centres.

Available in the full and growing range of pocket sizes, providing flexible, conservation-grade storage in one ringbinder album/box. Pocket entry is gained either from the short, long or two adjacent sides of the page to allow easy insertion of thinner papers.

All Timecare® Album Pages will accept a hanging bar for alternative use in a filing cabinet.

The Timecare® Album Pages opposite are available in either the HCL or Crystal Type 2 material. To make selection easy, product codes for both are beneath the corresponding image, identified with description 'HCL Film' or 'Crystal Type 2 Film'.

Specifications

- 100-micron Timecare® Crystal Polyester Type 2
- Binder edge 25mm
- 4 holes punched at 80mm centres



Linked Products: Timecare® Library Ringbinder Boxes pg 17, HAPK Mounting Sheets, V mounts pg 137, Type 2 Flat Weld Pockets pg69.

Product code	Description	Entry Edge	Pocket Size mm	Pocket Size inches	Pack qty
PYTCRP8609	A4, 1 pocket	Short	305 x 230	12 x 9 ¹ / ₁₆	50
PYTCRP8600	A4, 1 pocket*	Long	230 x 310	9 ¹ / ₁₆ x 12 ³ / ₁₆	50
PYTCRP8617	A4, 2 pockets	Short	116 x 303	4 ⁷ / ₁₆ x 11 ¹⁵ / ₁₆	50
PYTCRP8610	A4, 2 pockets	Long	230 x 150	9 ¹ / ₁₆ x 5 ⁷ / ₁₆	50
PYTCRP8601	A4, 2 pockets*	Short	151 x 230	5 ¹⁵ / ₁₆ x 9 ¹ / ₁₆	50
PYTCRP8608	A4, 3 pockets*	Short	102 x 230	4 x 9 ¹ / ₁₆	50
PYTCRP8603	A4, 4 pockets*	Short	75 x 230	2 ¹⁵ / ₁₆ x 9 ¹ / ₁₆	50
PYTCRP8602	A4, 4 pockets*	Long	151 x 113	5 ¹⁵ / ₁₆ x 4 ¹ / ₂	50
PYTCRP8611	A4, 4 pockets*	Long	116 x 150	4 ⁷ / ₁₆ x 5 ⁷ / ₁₆	50
PYTCRP8612	A4, 4 pockets	Short	75 x 230	2 ¹⁵ / ₁₆ x 9 ¹ / ₁₆	50
PYTCRP8618	A4, 4 pockets	Long	75 x 230	2 ¹⁵ / ₁₆ x 9 ¹ / ₁₆	50
PYTCRP8604	A4, 7 pockets	Short	42 x 230	1 ¹¹ / ₁₆ x 9 ¹ / ₁₆	50
PYTCRP8619	A4, 7 pockets	Long	42 x 230	1 ¹¹ / ₁₆ x 9 ¹ / ₁₆	50
PYTCRP8613	A4, 7 pockets	Short	42 x 230	1 ¹¹ / ₁₆ x 9 ¹ / ₁₆	50
PYTCRP8606	A4, 8 pockets	Short	76 x 112	3 x 4 ¹ / ₂	50
PYTCRP8615	A4, 12 pockets	Short	76 x 66	3 x 2 ⁵ / ₁₆	50
PYTCRP8607	A4, 12 pockets	Long	76 x 66	3 x 2 ⁵ / ₁₆	50
PYTCRP8614	A4, 20 pockets	Short	57 x 52	2 ¹ / ₄ x 2 ¹ / ₁₆	50
PYTCRP8605	A4, 20 pockets	Short	60 x 54	2 ³ / ₁₆ x 2 ¹ / ₁₆	50
PYTCRP8616	A4, 20 pockets	Short	65 x 43	2 ¹ / ₁₆ x 1 ⁷ / ₁₆	50
PYTCRP8630	A4, 1 pocket	Adjacent	230 x 310	9 ¹ / ₁₆ x 12 ¹³ / ₁₆	50
PYTCRP8631	A4, 2 pockets	Adjacent	116 x 303	4 ⁷ / ₁₆ x 11 ¹⁵ / ₁₆	50
PYTCRP8632	A4, 3 pockets	Adjacent	102 x 230	4 ⁷ / ₁₆ x 9 ¹ / ₁₆	50

Timecare® Polyester HCL Album Pages

Timecare® Album Pages for the safe storage and display of photographs, documents and ephemera. Made from a specially developed high clarity archival laminate (HCL) of polyester and virgin polyethylene which combines the strength of polyester with the weldability of polyethylene. Independently tested by the Image Permanence Centre and passes the PAT standards (Photographic Activity Test). They have a binder edge (25mm), with 4 holes punched at 80mm centres.

The wide variety of 'pockets' within the Timecare® Album Page range gives flexibility of storage in one ringbinder album/box. Pocket entry is gained either from the short or long side of the page.

All pages will accept a hanging bar for alternative use in a filing cabinet.

The Timecare® Album Pages opposite are available in either the HCL or Crystal type 2 material. To make selection easy, product codes for both are beneath the image, denoted by either 'HCL Film' or 'Crystal Type 2 Film'

Specifications

- 75-micron
- Overall page size: 315 x 260mm
- Binder edge: 25mm, 4 holes punched at 80mm centres
- Unique archival PET/PE laminate
- Suitable for Timecare® Ringbinder boxes
- Binder channel accepts hanging bar for storage in filing cabinet (Foolscap/Folio size)

Product code	Description	Thickness microns	Entry Edge	Pocket Size mm	Pocket Size inches	Pack qty
PYTCRP7609	A4, 1 pocket	75	Short	305 x 230	12 x 9 ¹ / ₁₆	50
PYTCRP7600	A4, 1 pocket*	75	Long	230 x 310	9 ¹ / ₁₆ x 12 ³ / ₁₆	50
PYTCRP7617	A4, 2 pockets	75	Short	116 x 303	4 ⁷ / ₁₆ x 11 ¹⁵ / ₁₆	50
PYTCRP7610	A4, 2 pockets	75	Long	230 x 150	9 ¹ / ₁₆ x 5 ⁷ / ₁₆	50
PYTCRP7601	A4, 2 pockets*	75	Short	151 x 230	5 ¹⁵ / ₁₆ x 9 ¹ / ₁₆	50
PYTCRP7608	A4, 3 pockets*	75	Short	102 x 230	4 x 9 ¹ / ₁₆	50
PYTCRP7603	A4, 4 pockets*	75	Short	75 x 230	2 ¹⁵ / ₁₆ x 9 ¹ / ₁₆	50
PYTCRP7602	A4, 4 pockets*	75	Long	151 x 113	5 ¹⁵ / ₁₆ x 4 ¹ / ₂	50
PYTCRP7611	A4, 4 pockets*	75	Long	116 x 150	4 ⁷ / ₁₆ x 5 ⁷ / ₁₆	50
PYTCRP7612	A4, 4 pockets	75	Short	75 x 230	2 ¹⁵ / ₁₆ x 9 ¹ / ₁₆	50
PYTCRP7618	A4, 4 pockets	75	Long	75 x 230	2 ¹⁵ / ₁₆ x 9 ¹ / ₁₆	50
PYTCRP7604	A4, 7 pockets	75	Short	42 x 230	1 ¹¹ / ₁₆ x 9 ¹ / ₁₆	50
PYTCRP7619	A4, 7 pockets	75	Long	42 x 230	1 ¹¹ / ₁₆ x 9 ¹ / ₁₆	50
PYTCRP7613	A4, 7 pockets	75	Short	42 x 230	1 ¹¹ / ₁₆ x 9 ¹ / ₁₆	50
PYTCRP7605	A4, 8 pockets	75	Short	76 x 112	3 x 4 ¹ / ₂	50
PYTCRP7615	A4, 12 pockets	75	Short	76 x 66	3 x 2 ⁵ / ₁₆	50
PYTCRP7607	A4, 12 pockets	75	Long	76 x 66	3 x 2 ⁵ / ₁₆	50
PYTCRP7614	A4, 20 pockets	75	Short	57 x 52	2 ¹ / ₄ x 2 ¹ / ₁₆	50
PYTCRP7605	A4, 20 pockets	75	Short	60 x 54	2 ³ / ₁₆ x 2 ¹ / ₁₆	50
PYTCRP7616	A4, 20 pockets	75	Short	65 x 43	2 ¹ / ₁₆ x 1 ⁷ / ₁₆	50

*Items for use in hanging files - in landscape format.



SUHBAR/009 A4 Hanging/Suspension Bar.

For Album/Ringbinder Boxes see Timecare® Ringbinder Boxes in the Boxes section p17.

For acid-free mounting paper inserts for album pages - see Papers section p85.

Linked Products: Mounting pages p84; V mounts p137; gloves p215.

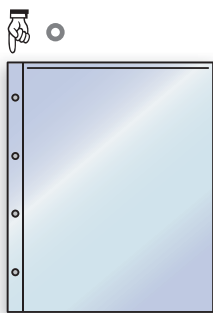

PYTCRP8609
Crystal Clear Polyester Type 2
PYTCRP7609
HCL Polyester/PE
Suitable for letters, comics and photographs
1 Pocket: H310 x W230mm

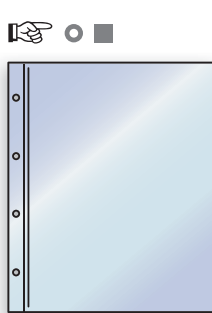

PYTCRP8600
Crystal Clear Polyester Type 2
PYTCRP7600
HCL Polyester/PE
Suitable for letters, comics and photographs
1 Pocket: H151 x W113mm

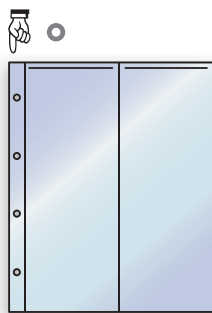

PYTCRP8617
Crystal Clear Polyester Type 2
PYTCRP7617
HCL Polyester/PE
Suitable for panorama prints, bookmarks etc.
2 Pockets: H303 x W116mm

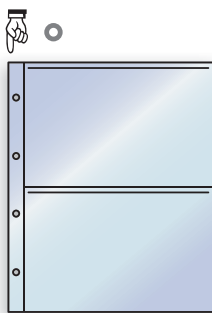

PYTCRP8610
Crystal Clear Polyester Type 2
PYTCRP7610
HCL Polyester/PE
Suitable for first-day covers
2 Pockets: H150 x W230mm

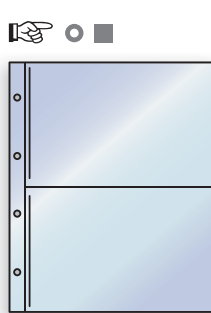

PYTCRP8601
Crystal Clear Polyester Type 2
PYTCRP7601
HCL Polyester/PE
Suitable for first-day covers
2 Pockets: H151 x W230mm

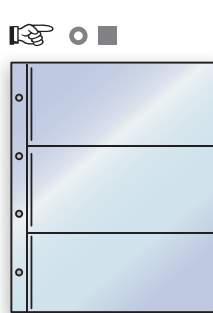

PYTCRP8608
Crystal Clear Polyester Type 2
PYTCRP7608
HCL Polyester/PE
Suitable for bank notes and stereo cards
3 Pockets: H102 x W230mm

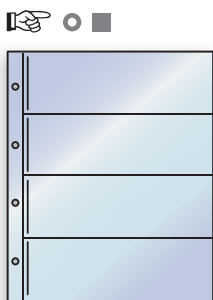

PYTCRP8603
Crystal Clear Polyester Type 2
PYTCRP7603
HCL Polyester/PE
Suitable for 120mm film strips and negatives
4 Strip Pockets: H75 x W230mm



PYTCRP8602
Crystal Clear Polyester Type 2
PYTCRP7602
HCL Polyester/PE
Suitable for postcards
4 Pockets: H150 x W116mm

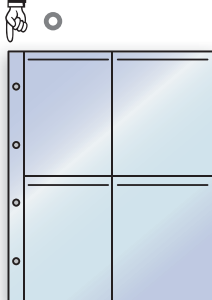

PYTCRP8611
Crystal Clear Polyester Type 2
PYTCRP7611
HCL Polyester/PE
Suitable for postcards
4 Pockets: H150 x W116mm

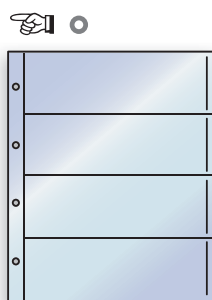

PYTCRP8612
Crystal Clear Polyester Type 2
PYTCRP7612
HCL Polyester/PE
Suitable for 120 film strips and negatives
4 Strip Pockets: H75 x W230mm



PYTCRP8618
Crystal Clear Polyester Type 2
PYTCRP7618
HCL Polyester/PE
Suitable for 120 film strips and negatives
4 Strip Pockets: H75 x W230mm



PYTCRP8604
Crystal Clear Polyester Type 2
PYTCRP7604
HCL Polyester/PE
Suitable for 35mm film strips and negatives
7 Pockets: H42 x W230mm

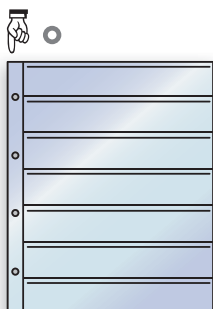

PYTCRP8619
Crystal Clear Polyester Type 2
PYTCRP7619
HCL Polyester/PE
Suitable for 35mm film strips and negatives
7 Strip Pockets: H42 x W230mm

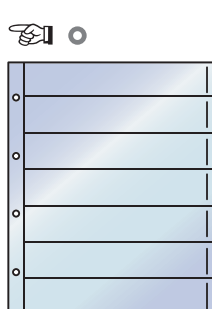

PYTCRP8613
Crystal Clear Polyester Type 2
PYTCRP7613
HCL Polyester/PE
Suitable for 35mm film strips and negatives
7 Strip Pockets: H42 x W230mm



PYTCRP8606
Crystal Clear Polyester Type 2
PYTCRP7606
HCL Polyester/PE
Suitable for 'cartes de visite' and playing cards
8 Pockets: H76 x W112mm

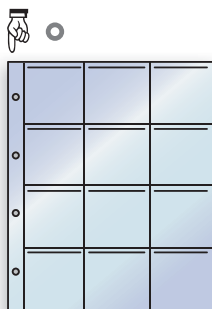

PYTCRP8615
Crystal Clear Polyester Type 2
PYTCRP7615
HCL Polyester/PE
Suitable for 6 x 7cm or 6 x 6cm mounted slides
12 Pockets: H76 x W66mm



PYTCRP8607
Crystal Clear Polyester Type 2
PYTCRP7607
HCL Polyester/PE
Suitable for 6 x 7cm or 6 x 6cm mounted slides
12 Pockets: H76 x W66mm

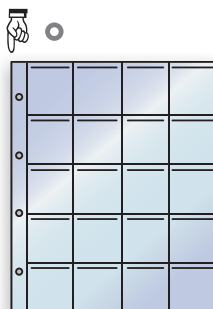

PYTCRP8614
Crystal Clear Polyester Type 2
PYTCRP7614
HCL Polyester/PE
Suitable for 35mm transparencies
20 Pockets: H57 x W52mm

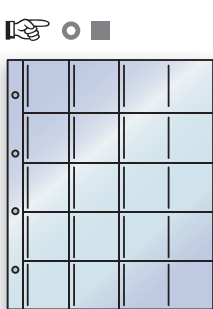

PYTCRP8605
Crystal Clear Polyester Type 2
PYTCRP7605
HCL Polyester/PE
Suitable for 35mm transparencies
20 Pockets: H60 x W54mm

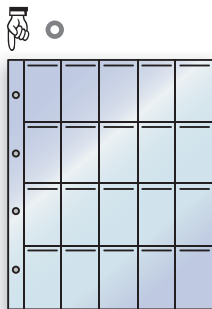

PYTCRP8616
Crystal Clear Polyester Type 2
PYTCRP7616
HCL Polyester/PE
Suitable for cigarette cards and tickets
20 Pockets: H65 x W43mm

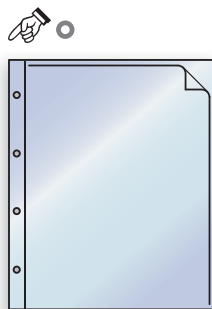

PYTCRP8630
Crystal Clear Polyester Type 2
Suitable for letters, comics and photographs
1 Pocket: H310 x W230mm

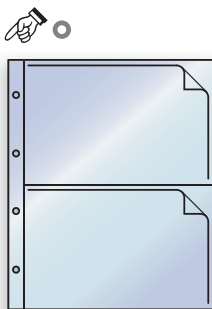

PYTCRP8631
Crystal Clear Polyester Type 2
Suitable for first-day covers
2 Pockets: 116 x 303

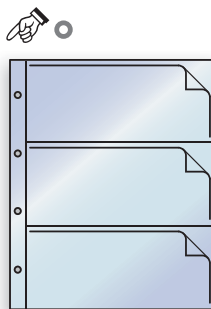

PYTCRP8632
Crystal Clear Polyester Type 2
Suitable for bank notes and stereo cards
3 Strip Pockets: 102 x 230mm

KEY

Pocket Openings:

- Left
- Right
- Top
- Adjacent

Suitable for:

- Ringbinder
- Filing Cabinet

Timecare® Crystal Polyester Type 2: Album Pages – Foolscap

An extension to the A4 Timecare® Crystal Polyester Type 2 Album Pages launched in 2013. Designed to fit the Foolscap Timecare® Library Ringbinder boxes and offered in three styles including open on two adjacent sides for easy insertion of thin papers. Other styles can be made to special order. CXD's Crystal Type 2 Polyester can be spot-welded using a hot tacking iron to locate items or fragments within the pages without the use of adhesives.

Specifications

- 100-micron Timecare® Crystal Polyester Type 2
- Binder edge 25mm
- 4 holes punched at 80mm centres

Product code	Description	Entry Edge	Pocket Size mm	Pocket Size inches	Pack qty
PYTCRP8636	Foolscap, 1 pocket	Adjacent	256 x 367	10 ¹ / ₄ x 14 ² / ₄	50
PYTCRP8637	Foolscap, 2 pockets	Adjacent	256 x 177	10 ¹ / ₄ x 6 ³ / ₂	50
PYTCRP8638	Foolscap, 3 pockets	Adjacent	256 x 114	10 ¹ / ₄ x 4 ³ / ₄	50

 **Linked Products:** Timecare® Library Ringbinder Boxes pg 18, HAPK Mounting Sheets, V mounts pg 137, Type 2 Flat Weld Pockets pg69.

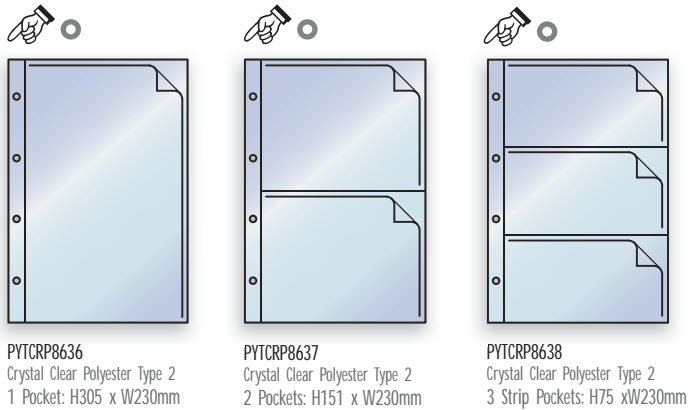

PYTCRP8636
Crystal Clear Polyester Type 2
1 Pocket: H305 x W230mm

PYTCRP8637
Crystal Clear Polyester Type 2
2 Pockets: H151 x W230mm

PYTCRP8638
Crystal Clear Polyester Type 2
3 Strip Pockets: H75 x W230mm

Drawings not to scale with A4, A3 and A2

Timecare® Crystal Polyester Type 2: Album Pages – Birth Certificate Page

An album page specifically designed for the archivist of family history to store and display British Birth Certificates. The page fits with the Premier Duo™ Timecare Certificate Ringbinder Box on page 18 of the Box section.

Specifications

- 100-micron Timecare® Crystal Polyester Type 2
- Binder edge 25mm
- 4 holes punched at 80mm centres
- External Page Size 288 x 406mm

Applications

Birth, Marriage and Death certificates

Product code	Description	Pocket Size mm	Pocket Size inches	Pack qty
PYTCRP8642	Certificate Page	265 x 400 x 25	10 ¹ / ₁₆ x 15 ³ / ₄ x ⁶ / ₄	50



Timecare® Crystal Polyester Type 2: Album Pages – A3 Crystal Clear Type 2 Polyester Album Pages designed to suit the A3 Timecare® Library Ringbinder Boxes, offered in two styles, traditional top opening and open on two adjacent sides for easy insertion of thin papers.

Other styles can be made to special order.

Specifications

- 100-micron Timecare® Crystal Polyester Type 2
- Binder edge 25mm
- 4 holes punched at 80mm centres

Product code	Description	Entry Edge	Pocket Size mm	Pocket Size inches	Pack qty
PYRPIA3242	A3, 1 pocket	Top	310 x 425 x 25	12 ¹ / ₄ x 16 ⁴ / ₄ x ⁶ / ₄	50
PYRPIA3120	A3, 2 pocket	Side	310 x 206	12 ¹ / ₄ x 8 ¹ / ₄ x ⁶ / ₄	50
PYRPIA1520	A3, 4 pocket	Top	205 x 154	8 ¹ / ₄ x 6 ¹ / ₄ x ⁶ / ₄	50
PYTCRP8639	A3, 1 pocket	Adjacent	310 x 425	12 ¹ / ₄ x 16 ⁴ / ₄ x ⁶ / ₄	50
PYTCRP8640	A3, 2 pocket	Adjacent	310 x 206	12 ¹ / ₄ x 8 ¹ / ₄ x ⁶ / ₄	50
PYTCRP8641	A3, 3 pocket	Adjacent	310 x 133	12 ¹ / ₄ x 5 ¹ / ₄ x ⁶ / ₄	50

 **Linked Products:** Timecare® Library Ringbinder Boxes pg 18, HAPK Mounting Sheets, V mounts pg 137, Type 2 Flat Weld Pockets pg69.

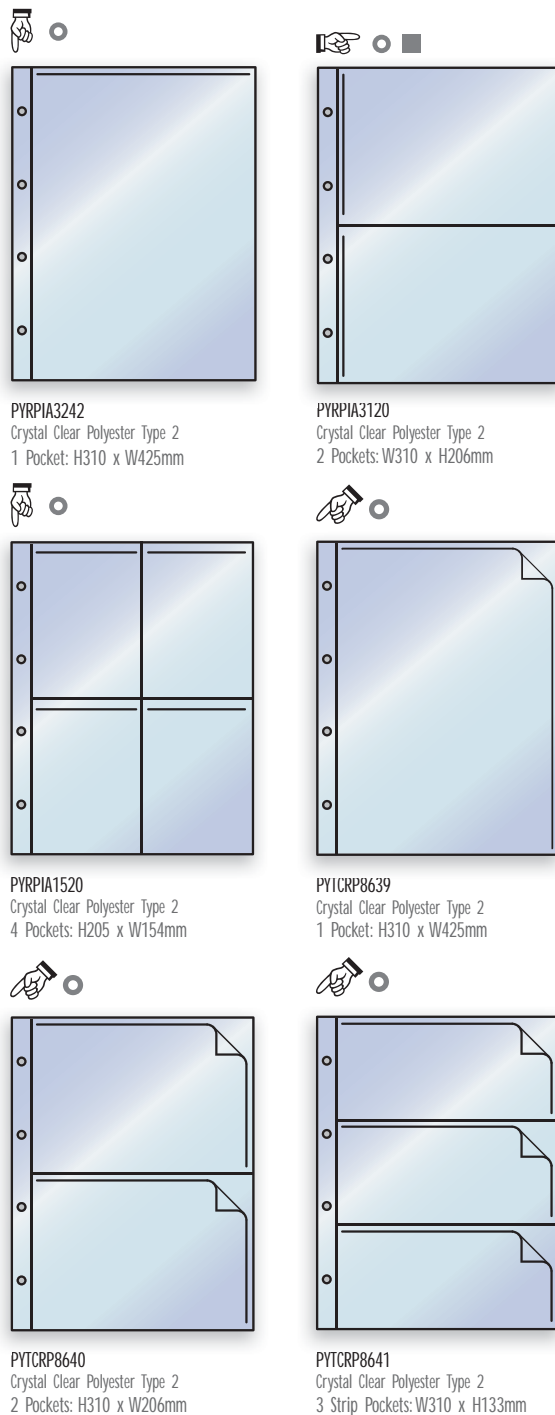

PYRPIA3242
Crystal Clear Polyester Type 2
1 Pocket: H310 x W425mm

PYRPIA3120
Crystal Clear Polyester Type 2
2 Pockets: W310 x H206mm

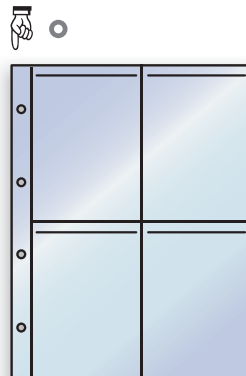

PYRPIA1520
Crystal Clear Polyester Type 2
4 Pockets: H205 x W154mm

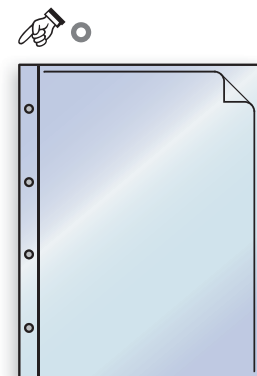

PYTCRP8639
Crystal Clear Polyester Type 2
1 Pocket: H310 x W425mm

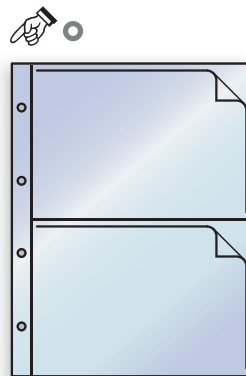

PYTCRP8640
Crystal Clear Polyester Type 2
2 Pockets: H310 x W206mm

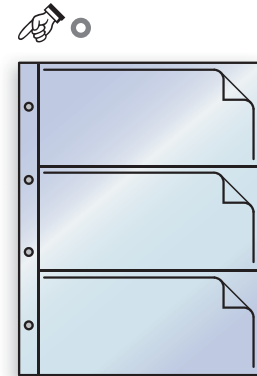

PYTCRP8641
Crystal Clear Polyester Type 2
3 Strip Pockets: W310 x H133mm

Timecare® Crystal Polyester Type 2: Album Pages – Prestige

A range of album pages slightly larger than the standard A4 size. They are manufactured from CXD's unique Crystal Polyester Type 2 to suit ringbinder box models: BXTCMB4243 and BXCLAS4244. The pages have an overall size of 395 x 410mm. Available in a variety of pocket sizes and two styles including open two adjacent sides on the single and double pocket pages.

Specifications

- External dimensions: 395 x 410mm
- 100-micron Timecare® Crystal Polyester Type 2
- Binder edge 25mm
- 4 holes punched at 80mm centres



Product code	Description	Entry Edge	Pocket Size mm	Pocket Size inches	Pack qty
PYTCRP8620	Prestige, 12 pockets	Short	90 x 130	3 ⁵ / ₁₆ x 5 ¹ / ₈	50
PYTCRP8621	Prestige, 12 pockets	Short	120 x 100	4 ⁷ / ₃₂ x 3 ⁹ / ₁₆	50
PYTCRP8622	Prestige, 9 pockets	Short	120 x 130	4 ⁷ / ₃₂ x 5 ¹ / ₈	50
PYTCRP8623	Prestige, 6 pockets	Short	120 x 200	4 ⁷ / ₃₂ x 7 ⁷ / ₈	50
PYTCRP8624	Prestige, 6 pockets	Short	180 x 130	7 ¹ / ₃₂ x 5 ¹ / ₈	50
PYTCRP8625	Prestige, 4 pockets	Short	180 x 200	7 ¹ / ₃₂ x 7 ⁷ / ₈	50
PYTCRP8626	Prestige, 2 pockets	Short	200 x 370	7 ⁷ / ₈ x 14 ¹ / ₁₆	50
PYTCRP8627	Prestige, 1 pocket	Short	370 x 410	14 ¹ / ₁₆ x 16 ³ / ₄	50

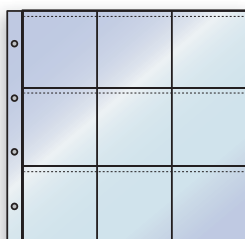

PYTCRP8622
Crystal Clear Polyester Type 2

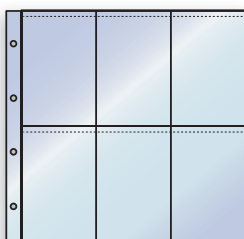

PYTCRP8623
Crystal Clear Polyester Type 2

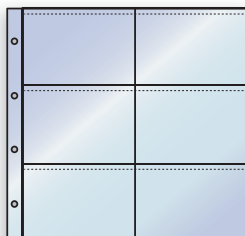

PYTCRP8624
Crystal Clear Polyester Type 2

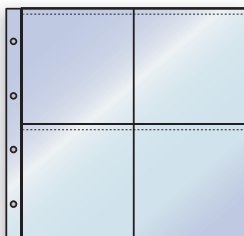

PYTCRP8625
Crystal Clear Polyester Type 2

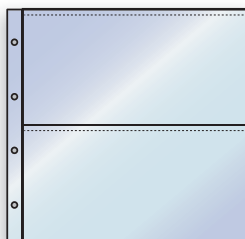

PYTCRP8626
Crystal Clear Polyester Type 2

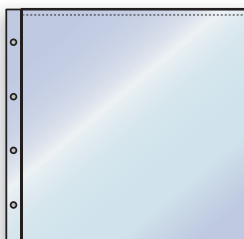

PYTCRP8627
Crystal Clear Polyester Type 2

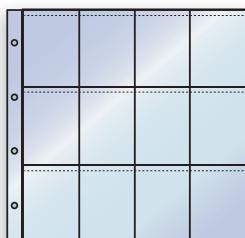

PYTCRP8620
Crystal Clear Polyester Type 2

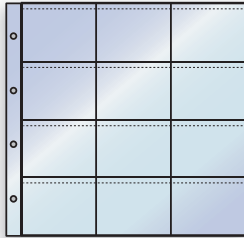

PYTCRP8621
Crystal Clear Polyester Type 2

Timecare® Crystal Polyester Type 1 A4, Foolscape and A3 Album Pages

Timecare® Crystal Polyester Type 1 Album Pages offer superb visibility for safe storage and presentation. Designed to fit the Timecare® Ringbinder Box System. Producing these complex welds in the crystal clear, but difficult to weld Melinex® 400 (CXD type 1) polyester is achieved using ultrasonic welding technology giving a strong, high-quality finish. Album Pages without multiple pockets, may also be bead-welded.

Available in A4, Foolscape and A3. The A2 sizes are listed separately below, as they conform to slightly different specification.

Specifications

- Melinex® 400 pure polyester (CXD Crystal Polyester Type 1)
- 75-micron
- Binder edge 25mm
- 4 holes and 2 holes punched at 80mm centres



Product code	Description	Entry Edge	Size mm	Size inches	Pack qty
PYRPE0420	A4, No Binding Edge	Long	320 x 420	12 ⁵ / ₃₂ x 16 ¹⁷ / ₃₂	25
PYRPE0305	A4, No Binding Edge	Long	225 x 305	8 ⁵ / ₁₆ x 12 ¹ / ₁₆	25
PYRPE0320	A4+, No Binding Edge	Long	255 x 320	10 ¹ / ₁₆ x 12 ⁵ / ₁₆	25
PYRPE0148	A5, 2 Hole, No Binding Edge	Short	225 x 148	8 ⁵ / ₁₆ x 5 ³ / ₁₆	100
PYRPAS7037	Foolscape, Binding Edge	Short	383 x 282	15 ¹ / ₁₆ x 11 ¹ / ₈	50
PYRPB10310	A3, Binding Edge	Short	425 x 330	16 ³ / ₄ x 13	50

Acid-free Mounting Paper Inserts for album pages, Papers section p85. V mounts. For Album/Ringbinder Boxes see Timecare® Ringbinder Boxes, Boxes section p18.

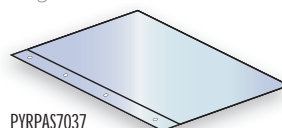

PYRPAS7037
Binding Edge

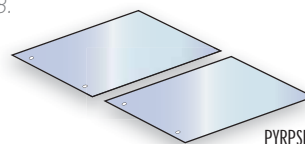

PYRPE0148
No Binding Edge

Timecare® Crystal Polyester Type 1 A2 Album Pages

Specifications

- Melinex® 400 pure polyester (CXD Crystal Polyester Type 1)
- 75-micron
- Binder edge 25mm
- 8 holes punched at 80mm centres

Product code	Description	Entry Edge	Size mm	Size inches	Pack qty
PYRPAP7480	A2, 1 pocket	Top	610 x 420	24 ¹ / ₁₆ x 16 ¹⁷ / ₃₂	25
PYRPAP7481	A2, 2 x A3 pockets	Top	300 x 420	11 ³ / ₁₆ x 16 ¹⁷ / ₃₂	25
PYRPAP7482	A2, 4 x A4 pockets	Top	300 x 210	11 ³ / ₁₆ x 8 ¹ / ₁₆	25

Drawings not to scale with other sizes

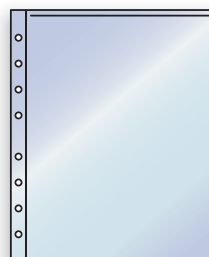

PYRPAP7480
Crystal Polyester Type 1

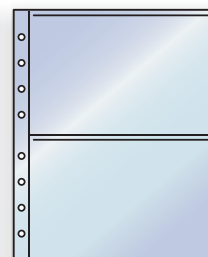

PYRPAP7481
Crystal Polyester Type 1

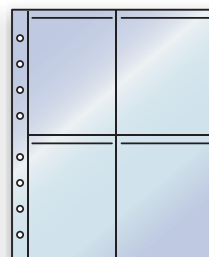

PYRPAP7482
Crystal Polyester Type 1

Timecare® Crystal Polyester Type I: Storage Pockets

Clear Melinex® polyester (CXD type I) bead-welded pockets in a wide range of sizes. Independently tested and pass the Photographic Activity Test. They do not have a binder edge or punched holes.

Polyester is known as the most stable and chemically inert plastic used for conservation storage. It offers greater clarity, strength, rigidity than polypropylene or polyethylene.

Boxes are available to accommodate any of the pockets/enclosures.

Specifications

- Clear Melinex® polyester
- Chemically inert
- Sparkling optical clarity
- Non-yellowing and non-brittling
- Free of plasticisers and surface-coatings
- Bead-welded
- Maximum size 1524mm (60")
- Choice of openings
- Made-to-measure service available

Applications

Safe storage and display of photographs, transparencies, prints, documents, comics and ephemera.

 **Linked Products:** Ultrasonic Spot Welder p174, Separator Sheets p84, Mounting Sheets p84; Mount Boards p45, 74, 109, 113-114 and 116; Single Crease Folders p44; Four-flap Folders p55; P-Boxes p12, 74, Solander Boxes p16.

Information

CXD P-Box Photographic Mounting and Storage System

This is a comprehensive system for co-ordinating various CXD-linked products including pHoton™ papers, pHoton™ folders, Heritage Archival pHotokraft™ (HAPK) single-crease folders, Polyester pockets and Timecare® Heritage Museum and Conservation mountboards. All are available to suit each size of Premier Duo™ P-Boxes.

These are based on photographic print sizes and are part of the CXD P-Box system of boxes, folders, mounting sheets and pockets.

Product code	Description	Box ref	Thickness microns	Entry edge	Pocket size mm	Pocket size inches	Pack qty
PYSP0000	Open one short side	-	75	Short	64 x 95	2½ x 3¾	50
PYSP0A0000	Open two adjacent sides	-	75	Adjacent	64 x 95	2½ x 3¾	50
PYSP0L0000	Open one long side	-	75	Long	64 x 95	2½ x 3¾	50
PYSP0S0001	Open one short side	-	75	Short	75 x 75	2⅞ x 2⅞	50
PYSP0A0001	Open two adjacent sides	-	75	Adjacent	75 x 75	2⅞ x 2⅞	50
PYSP0L0001	Open one long side	-	75	Long	75 x 75	2⅞ x 2⅞	50
PYSP0S1000	Open one short side	-	75	Short	77 x 115	3⅞ x 4½	50
PYSP0A1000	Open two adjacent sides	-	75	Adjacent	77 x 115	3⅞ x 4½	50
PYSP0L1000	Open one long side	-	75	Long	77 x 115	3⅞ x 4½	50
PYSP0S0041	Open one short side	-	75	Short	95 x 197	3¾ x 7¾	50
PYSP0A0041	Open two adjacent sides	-	75	Adjacent	95 x 197	3¾ x 7¾	50
PYSP0L0041	Open one long side	-	75	Long	95 x 197	3¾ x 7¾	50
PYSP0S0002	Open one short side	-	75	Short	104 x 104	4¼ x 4¼	50
PYSP0A0002	Open two adjacent sides	-	75	Adjacent	104 x 104	4¼ x 4¼	50
PYSP0L0002	Open one long side	-	75	Long	104 x 104	4¼ x 4¼	50
PYSP0S0051	Open one short side	-	75	Short	105 x 155	4¼ x 6¼	50
PYSP0A0051	Open two adjacent sides	-	75	Adjacent	105 x 155	4¼ x 6¼	50
PYSP0L0051	Open one long side	-	75	Long	105 x 155	4¼ x 6¼	50
PYSP0S0005	Open one short side	-	75	Short	108 x 159	4¼ x 6¼	50
PYSP0A0005	Open two adjacent sides	-	75	Adjacent	108 x 159	4¼ x 6¼	50
PYSP0L0005	Open one long side	-	75	Long	108 x 159	4¼ x 6¼	50
PYSP0S0003	Open one short side	-	75	Short	108 x 133	4¼ x 5¼	50
A6+							
PYSP0S0004	Open one short side - up to A6	-	75	Short	99 x 151	3⅞ x 5⅞	50
PYSP0A0004	Open two adjacent sides - up to A6	-	75	Adjacent	99 x 151	3⅞ x 5⅞	50
PYSP0L0004	Open one long side - up to A6	-	75	Long	99 x 151	3⅞ x 5⅞	50
PYTCPS1115	Open two short sides - tube	-	75	Opposite	115 x 155	4⅞ x 6¼	50
PYSP0S0006	Open one short side - up to A6 -	-	75	Short	115 x 158	4⅞ x 6¼	50
PYSP0A0006	Open two adjacent sides - up to A6	-	75	Adjacent	115 x 158	4⅞ x 6¼	50
PYSP0L0006	Open one long side - up to A6	-	75	Long	115 x 158	4⅞ x 6¼	50
PYSP0L1214	Open one long side	-	75	Long	120 x 140	4⅞ x 5⅞	50
PYSP0A1214	Open two adjacent sides	-	75	Adjacent	120 x 140	4⅞ x 5⅞	50
PYSP0S0052	Open one short side - 75 Short 5	-	75	Short	127 x 178	5 x 7	50
PYSP0A0052	Open two adjacent sides - 75 Adjacent 5	-	75	Adjacent	127 x 178	5 x 7	50
PYSP0L0052	Open one long side - 75 Long 5	-	75	Long	127 x 178	5 x 7	50
PYSP0S0071	Open one short side 75 Short 5 x	-	75	Short	127 x 203	5 x 8	50
A5							
PYSP0D0021	Open one short side	-	75	Short	131 x 131	5⅞ x 5⅞	50
PYSP0S0053	Open one short side (5 x 7 prints)	PO	75	Short	133 x 184	5⅞ x 7¼	50
PYSP0A0053	Open two adjacent sides (5 x 7 prints)	PO	75	Adjacent	133 x 184	5⅞ x 7¼	50
PYSP0L0053	Open one long side (5 x 7 prints)	PO	75	Long	133 x 184	5⅞ x 7¼	50
PYSP0S1419	Open one short side	-	75	Short	140 x 190	5⅞ x 7⅞	50
PYSP0L1419	Open one long side	-	75	Long	140 x 190	5⅞ x 7⅞	50
PYSP0A1419	Open two adjacent sides	-	75	Adjacent	140 x 190	5⅞ x 7⅞	50
A5+							
PYSP0S0007	Open one short side - up to A5	-	75	Short	152 x 229	6 x 9	50
PYSP0A0007	Open two adjacent sides - A5	-	75	Adjacent	152 x 229	6 x 9	50
PYSP0L0007	Open one long side - up to A5	-	75	Long	152 x 229	6 x 9	50
PYSP0S0009	Open one short side (8 x 10 prints)	P1	75	Short	210 x 260	8⅞ x 10¼	50
PYSP0A0009	Open two adjacent sides (8 x 10 prints)	P1	75	Adjacent	210 x 260	8⅞ x 10¼	50
PYSP0L0009	Open one long side (8 x 10 prints)	P1	75	Adjacent	210 x 260	8⅞ x 10¼	50

Opening Options and Entry edge

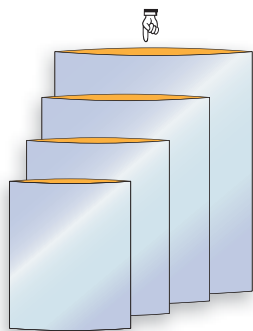

Open on one SHORT side

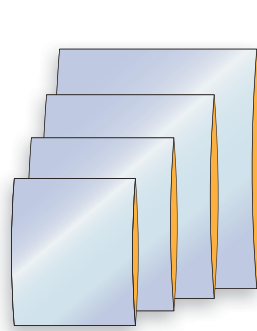

Open on one LONG side

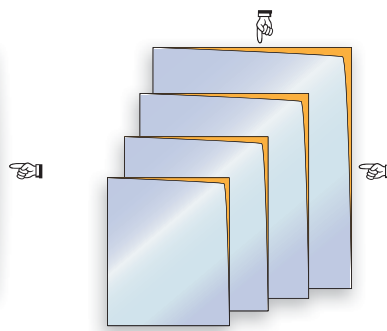

Open on two ADJACENT sides

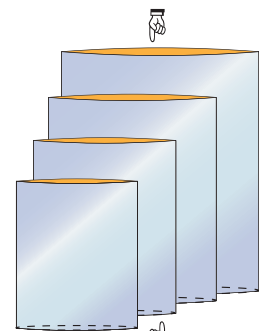

Open on both SHORT sides



Product code	Description	Box ref	Thickness microns	Entry edge	Pocket size mm	Pocket size inches	Pack qty
A4							
PYSPOS0082	Open one short side - A4	A4	75	Short	216 x 308	8½ x 12½	25
PYSPOA0082	Open two adjacent sides - A4	A4	75	Adjacent	216 x 308	8½ x 12½	25
PYSPOL0082	Open one long side - A4	A4	75	Long	216 x 308	8½ x 12½	25
PYSPOS0008	Open one short side - up to A4	-	75	Short	229 x 311	9 x 12¼	25
PYSPOA0008	Open two adjacent sides - up to A4	-	75	Adjacent	229 x 311	9 x 12¼	25
PYSPOL0008	Open one long side - up to A4	-	75	Long	229 x 311	9 x 12¼	25
PYSPOL2333	Open one long side	-	75	Long	230 x 330	9¼ x 12¾	25
PYSPOS0081	Open one short side - Folio	-	75	Short	229 x 356	9 x 14	25
PYSPOA0081	Open two adjacent sides - Folio	-	75	Adjacent	229 x 356	9 x 14	25
PYSPOL0081	Open one long side - Folio	-	75	Long	229 x 356	9 x 14	25
PYSPOS0069	Open one short side	-	75	Short	247 x 187	9¾ x 7½	25
PYSPOA0069	Open two adjacent sides	-	75	Adjacent	247 x 187	9¾ x 7½	25
PYSPOL0069	Open one long side	-	75	Long	247 x 187	9¾ x 7½	25
PYSPOS2531	Open one short side	-	75	Short	250 x 310	9¾ x 12¾	25
PYSPOA2531	Open two adjacent sides	-	75	Adjacent	250 x 310	9¾ x 12¾	25
PYSPOS0010	Open one short side (10 x 12 prints)	P2	75	Short	260 x 311	10¼ x 12¼	25
PYSPOA0010	Open two adjacent sides (10 x 12 prints)	P2	75	Adjacent	260 x 311	10¼ x 12¼	25
PYSPOL0010	Open one long side (10 x 12 prints)	P2	75	Long	260 x 311	10¼ x 12¼	25
PYSPOA0112	Open two adjacent sides	-	75	Adjacent	270 x 322	10¾ x 12½	25
PYSPOS0112	Open one short side	-	75	Short	270 x 322	10¾ x 12½	25
PYSPOS0011	Open one short side (11 x 14 prints)	PX	75	Short	286 x 362	11¼ x 14¼	25
PYSPOA0011	Open two adjacent sides (11 x 14 prints)	PX	75	Adjacent	286 x 362	11¼ x 14¼	25
PYSPOL0011	Open one long side (11 x 14 prints)	PX	75	Long	286 x 362	11¼ x 14¼	25
A3+							
PYSPOS0015	Open one short side - A3	-	75	Short	305 x 429	12 x 16¾	25
PYSPOA0015	Open two adjacent sides - A3	-	75	Adjacent	305 x 429	12 x 16¾	25
PYSPOL0015	Open one long side - A3	-	75	Long	305 x 429	12 x 16¾	25
PYSPOA3143	Open two adjacent sides	-	75	Adjacent	310 x 430	12¾ x 16¾	25
PYSPOL3143	Open one long side	-	75	Long	310 x 430	12¾ x 16¾	25
PYSPOS0012	Open one short side	P3	75	Short	311 x 413	12¼ x 16¼	25
PYSPOA0012	Open two adjacent sides	P3	75	Adjacent	311 x 413	12¼ x 16¼	25
PYSPOL0012	Open one long side	P3	75	Long	311 x 413	12¼ x 16¼	25
PYSPOL4151	Open one long side	-	75	Long	410 x 510	16¼ x 20¾	25
PYSPOA4151	Open two adjacent sides	-	75	Adjacent	410 x 510	16¼ x 20¾	25
PYSPOS0013	Open one short side	P4	75	Short	413 x 514	16¼ x 20¼	25
PYSPOA0013	Open two adjacent sides	P4	75	Adjacent	413 x 514	16¼ x 20¼	25
PYSPOL0013	Open one long side	P4	75	Long	413 x 514	16¼ x 20¼	25
A2+							
PYSPOS0016	Open one short side - A2	-	75	Short	428 x 603	16¾ x 23¾	25
PYSPOA0016	Open two adjacent sides - A2	-	75	Adjacent	428 x 603	16¾ x 23¾	25
PYSPOL0016	Open one long side - A2	-	75	Long	428 x 603	16¾ x 23¾	25
PYSPOA4361	Open two adjacent sides - A2	-	75	Adjacent	430 x 610	16¾ x 24¼	25
PYSPOA5161	Open two adjacent sides	-	75	Adjacent	510 x 610	20¾ x 24¼	25
PYSPOL5166	Open one long side	-	75	Long	510 x 660	20¾ x 25¾	25
PYSPOS0014	Open one short side - A2	P5	75	Short	514 x 616	20¼ x 24¼	25
PYSPOA0014	Open two adjacent sides - A2	P5	75	Adjacent	514 x 616	20¼ x 24¼	25
PYSPOL0014	Open one long side - A2	P5	75	Long	514 x 616	20¼ x 24¼	25
A1+							
PYSPOA6080	Open two adjacent sides	-	100	Adjacent	600 x 800	23¾ x 31½	10
PYSPOA6084	Open two adjacent sides - A1	-	100	Adjacent	600 x 840	23¾ x 33¼	10
PYSPOS0017	Open one short side - A1	-	75	Short	603 x 853	23¼ x 33¾	10
PYSPOA0017	Open two adjacent sides - A1	-	75	Adjacent	603 x 853	23¼ x 33¾	10
PYSPOL0017	Open one long side - A1	-	75	Long	603 x 853	23¼ x 33¾	10
PYSPOA6181	Open 2 adjacent sides	-	100	Adjacent	610 x 810	24¼ x 31¾	10
PYSPOL6181	Open one long side	-	100	Long	610 x 810	24¼ x 31¾	10
PYSPOL6185	Open one long side	-	100	Long	610 x 850	24¼ x 33¾	10
PYSPOA6185	Open 2 adjacent sides	-	100	Long	610 x 850	24¼ x 33¾	10
PYSPOA7100	Open two adjacent sides	-	100	Adjacent	700 x 1010	27¾ x 39¾	10
PYSPOL7100	Open one long side	-	100	Long	710 x 1010	27¾ x 39¾	10
PYSPOS0018	Open one short side - OS Map	-	75	Short	762 x 1014	30 x 39½	10
PYSPOA0018	Open two adjacent sides - OS Map	-	75	Adjacent	762 x 1014	30 x 39½	10
PYSPOL0018	Open one long side - OS Map	-	75	Long	762 x 1014	30 x 39½	10
PYSPOA7811	Open two adjacent sides	-	100	Adjacent	790 x 1190	31¼ x 46¾	10
PYSPOL7911	Open one long side	-	100	Long	790 x 1190	31¼ x 46¾	10
PYSPOA8012	Open two adjacent sides	-	100	Adjacent	810 x 1210	31¾ x 47¼	10
PYSPOL8012	Open one long side	-	100	Long	810 x 1210	31¾ x 47¼	10
PYSPOA8419	Open two adjacent sides	-	100	Adjacent	850 x 1200	33½ x 47¼	10
PYSPOL8512	Open one long side	-	100	Long	850 x 1200	33½ x 47¼	10
LP Covers							
PYSPOS0121	Open one short side - LP Covers	-	75	Short	312 x 312	12½ x 12½	10
PYSPOA0121	Open two adjacent sides - LP Covers	-	75	Adjacent	312 x 312	12½ x 12½	10
PYSPOL0121	Open one long side - LP Covers	-	75	Long	312 x 312	12½ x 12½	10
PYSPOS0131	Open one short side - LP Covers	-	75	Short	413 x 413	16¼ x 16¼	10
PYSPOA0131	Open two adjacent sides - LP Covers	-	75	Adjacent	413 x 413	16¼ x 16¼	10
PYSPOL0131	Open one long side - LP Covers,	-	75	Long	413 x 413	16¼ x 16¼	10

CXD P-box Photographic Mounting and Storage System

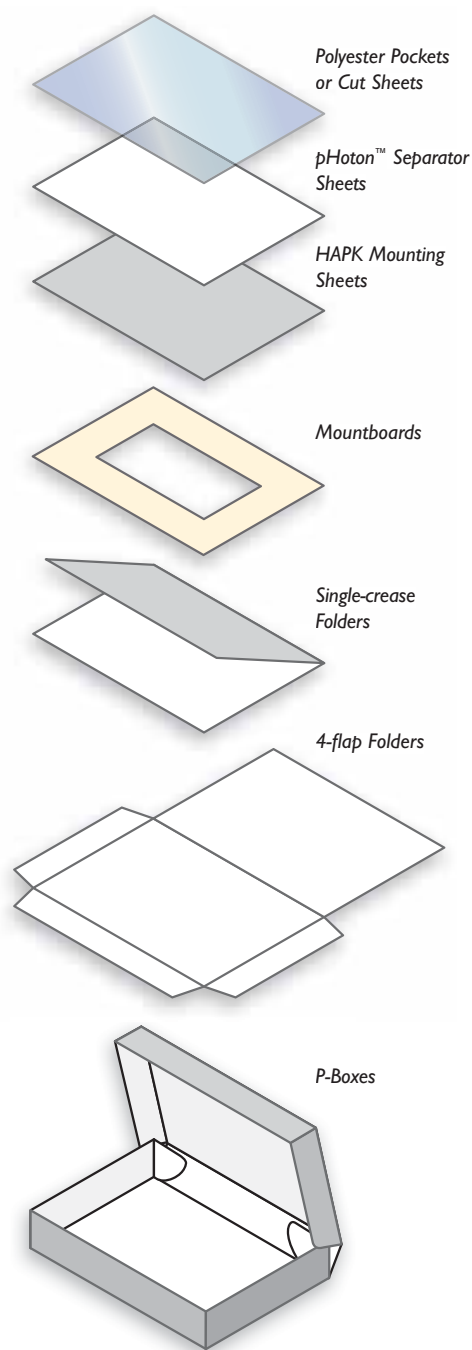

Information

P-Box Size Guide

Glass plate sizes

P0 = 5" x 7"

PZ = 10" x 7"

Photographic print sizes

P1 = 8" x 10"

P2 = 10" x 12"

P3 = 12" x 16"

PX = 14" x 11"

P4 = 16" x 20"

P5 = 20" x 24" or A2

Crystal Polyester Pockets

Timecare® Crystal Polyester Type 2; Storage Pockets

A new range of flat-welded storage pockets in popular sizes manufactured from CXD's 100-micron Timecare® Crystal Polyester Type 2. This flat-weld style of pocket has a wider weld but avoids the 'edge-bulking' of traditional bead-welded pockets. This means documents and photographs lie flatter within their box or binder.

A-size pockets have a choice of openings; open short side, long side or two adjacent sides to aid the insertion of delicate items.

Special sizes can be made to order. Contact the Call Centre for details

Product code	Description	Thickness microns	Entry edge	Pocket size mm	Pocket size inches	Pack qty
PYFWOA0007	Polyester Flat Weld Pockets - A5+	100	Open two adjacent sides	152 x 229	9 ⁷ / ₃₂ x 12 ³ / ₆₄	50
PYFWOA0053	Polyester Flat Weld Pockets - P0	100	Open two adjacent sides	184 x 133	12 ¹³ / ₆₄ x 16 ⁶ / ₆₄	50
PYFWOA0009	Polyester Flat Weld Pockets - P1	100	Open two adjacent sides	210 x 260	14 ¹¹ / ₆₄ x 18 ⁵⁷ / ₆₄	50
PYFWOA0082	Polyester Flat Weld Pockets - A4	100	Open two adjacent sides	216 x 308	16 ⁶ / ₆₄ x 20 ⁷ / ₆₄	50
PYFWOA0008	Polyester Flat Weld Pockets - A4	100	Open two adjacent sides	229 x 311	24 ¹ / ₆₄ x 24 ¹ / ₆₄	50
PYFWOA0081	Polyester Flat Weld Pockets - Folio	100	Open two adjacent sides	229 x 356	24 ¹ / ₆₄ x 31 ⁵⁷ / ₆₄	50
PYFWOL0069	Polyester Flat Weld Pockets - PZ	100	Open one long side	247 x 187	31 ¹ / ₂ x 47 ¹ / ₄	50
PYFWOA0014	Polyester Flat Weld Pockets - P5	100	Open two adjacent sides	247 x 187	9 ⁷ / ₃₂ x 12 ³ / ₆₄	50
PYFWOA0011	Polyester Flat Weld Pockets - PX	100	Open two adjacent sides	247 x 187	12 ³ / ₆₄ x 16 ⁶ / ₆₄	50
PYFWOA0015	Polyester Flat Weld Pockets - A3	100	Open two adjacent sides	305 x 429	14 ¹¹ / ₆₄ x 18 ⁵⁷ / ₆₄	50
PYFWOA0010	Polyester Flat Weld Pockets - P2	100	Open two adjacent sides	311 x 260	16 ⁶ / ₆₄ x 20 ⁷ / ₆₄	50
PYFWFC7037	Polyester Flat Weld Pockets - Foolscap	100	Open two adjacent sides	374 x 254	24 ¹ / ₆₄ x 24 ¹ / ₆₄	50
PYFWOA0012	Polyester Flat Weld Pockets - P3	100	Open two adjacent sides	413 x 311	24 ¹ / ₆₄ x 31 ⁵⁷ / ₆₄	50
PYFWOA0013	Polyester Flat Weld Pockets - P4	100	Open two adjacent sides	514 x 413	31 ¹ / ₂ x 47 ¹ / ₄	50

Opening Options and Entry Edge

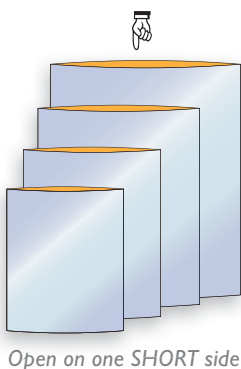
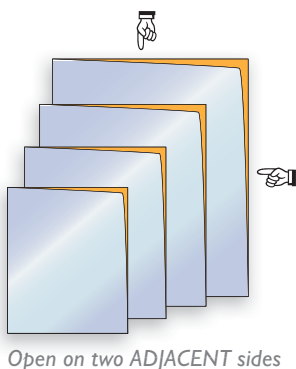
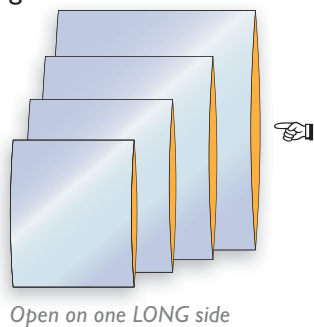

Timecare® Crystal Paperbacks

Timecare® Crystal Paperback: 170gsm PHIPAP Display Sleeve

Timecare® Crystal Paperback protectors comprise crystal clear polyester covers which are thermally welded onto an acid-free paper or board backing sheets. The acid-free backing paper/board offers support while also acting as a humidity buffer. They prevent abrasion and enable safe handling with clear visibility of the stored documents. Variations possible to special order.

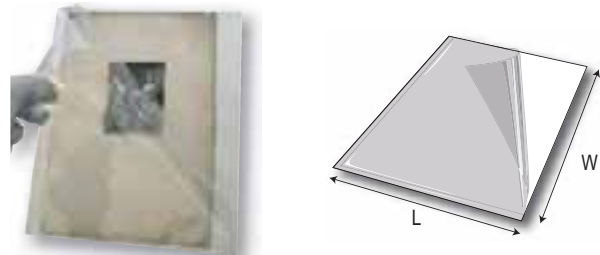

Product code	Polyester thickness micron	Entry Edge	Size mm L x W	Size inches L x W	Pack qty
FDHEPR0031	75	Adjacent	250 x 310		25
FDHEPR0041	75	Adjacent	310 x 410		25
FDHEPR0048	75	Adjacent	360 x 480		25
FDHEPR0051	75	Adjacent	410 x 510		25
FDHEPR0061	75	Adjacent	610 x 610		25
FDHEPR0081	75	Adjacent	610 x 810		25
FDHEPR0121	75	Adjacent	800 x 1200		25
FDHEP00031	75	Long	250 x 310		25
FDHEP00041	75	Long	310 x 410		25
FDHEP00048	75	Long	360 x 480		25
FDHEP00051	75	Long	410 x 510		25
FDHEP00061	75	Long	610 x 610		25
FDHEP00081	75	Long	610 x 810		25
FDHEP00121	75	Long	800 x 1200		25

Also available in 100 micron Polyester Type 2 to special order. Please call for further details

Timecare® Crystal Paperback: 400gsm PHIDOS Display Folder

Acid-free, single-crease board (400gsm Stouls 'Satin' Conservation Board) folder with Melinex® for the support and display of documents and photographs. Polyester film inside, film thermally sealed along the edge allows access from three sides.

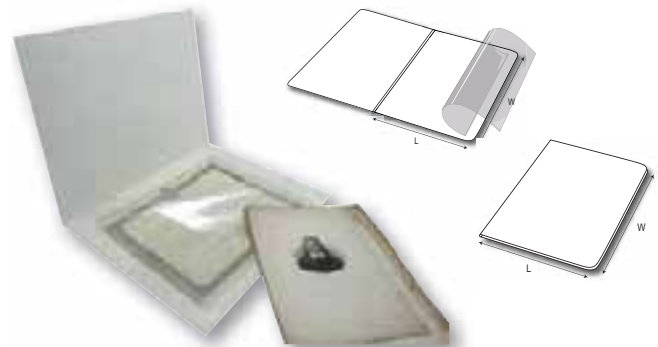

Product code	Polyester thickness micron	Colour	Size mm L x W	Size inches L x W	Pack qty
FDSTDP2126	75	Cream	190 x 250	7 ¹ / ₂ x 9 ⁹ / ₁₆	10
FDSTDP2433	75	Cream	220 x 310	8 ¹¹ / ₁₆ x 12 ³ / ₁₆	10
FDSTDP3343	75	Cream	310 x 410	12 ³ / ₁₆ x 16 ¹ / ₁₆	10

Timecare® Crystal Paperback: 350gsm PHICART Display Support

Acid-free 350gsm Heritage Archival pHotokraft™ backing paper with Melinex® polyester film cover. Film thermally sealed along the edge allows access from three sides.

For the support and display of documents and photographs.

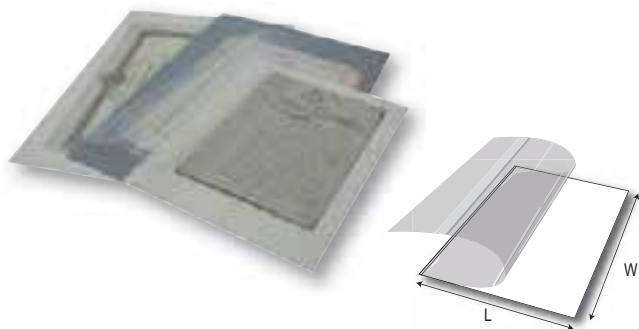

Product code	Polyester Thickness microns	Colour	Size mm L x W	Size inches L x W	Pack qty
FDARPR2025	75	Cream	220 x 260	8 ¹ / ₁₆ x 10 ¹ / ₄	10
FDARPR2430	75	Cream	250 x 310	9 ³ / ₁₆ x 12 ¹ / ₁₆	10
FDARPR3040	75	Cream	310 x 410	12 ¹ / ₁₆ x 16 ¹ / ₁₆	10
FDARPR4050	75	Cream	410 x 510	16 ¹ / ₁₆ x 20 ¹ / ₁₆	10
FDARPR5060	75	Cream	510 x 610	20 ¹ / ₁₆ x 24	10

Timecare® Crystal Paperback: 830gsm PHIDOC Display Support

830gsm/1.2mm Stouls 'Satin' Conservation Board, Off White backing with polyester film cover. Film thermally sealed along the edge allows access from three sides. For the support and display of documents and photographs.

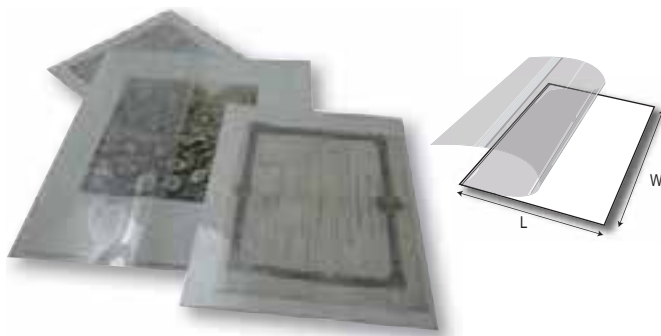

Product code	Polyester Thickness microns	Colour	Size mm L x W	Size inches L x W	Pack qty
FDMBPR2430	75	Cream	250 x 310	9 ³ / ₁₆ x 12 ¹ / ₁₆	25
FDMBPR3040	75	Cream	310 x 410	12 ¹ / ₁₆ x 16 ¹ / ₁₆	25
FDMBPR4050	75	Cream	410 x 510	16 ¹ / ₁₆ x 20 ¹ / ₁₆	25
FDMBPR4154	75	Cream	415 x 540	16 ¹ / ₁₆ x 21 ¹ / ₄	25
FDMBPR5060	75	Cream	510 x 610	20 ¹ / ₁₆ x 24	25
FDMBPR5166	75	Cream	510 x 660	20 ¹ / ₁₆ x 26	25
FDMBPR6080	75	Cream	610 x 810	24 x 31 ¹ / ₁₆	25

Timecare® Coin & Medal Protectors

Designed to hold coins in album pages without the need to use adhesives, these can be placed in Timecare® album pages for dense storage. Once folded, the enclosure gives protection as well as complete visibility of the coin on the two sides.

Manufactured from 400gsm acid free Stouls 'Satin' Conservation Board with 2 round windows covered with polyester.

Applications

Filing coins in Timecare® Album Page pockets

Specifications

- Size: open – 50 x 100/folded – 50 x 50mm
- Colour: Cream

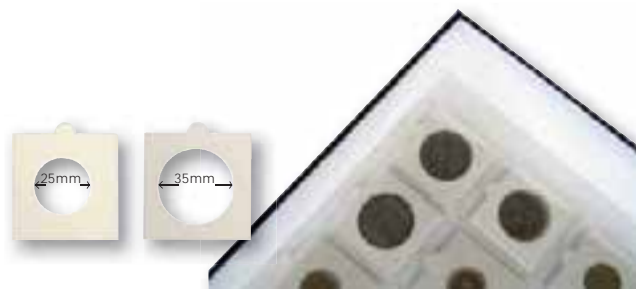

Product code	Description mm	Description inches	Pack qty
PYMONT0025	25mm	6 ³ / ₁₆	100
PYMONT0035	35mm	1 ¹ / ₁₆	100

Timecare® Ringbinder Dividers

A set of 6 tabbed inserts allowing separation and identification of documents within Timecare® album pages. Made from 230gsm Neutral Grey, Heritage Archival pHotokraft™ paper. 4 holes punched at 80mm centres.



Product code	Description
PYRPIN0001	Set of 6 dividers for Premier Duo™ BXCLAS0003
PYRPIN0002	Set of 6 dividers for Premier Duo™ BXCLAS2833 and BXCLAS2130
PYRPIN0003	Set of 6 dividers for Premier Duo™ BXTOMB3434
PYRPIN0004	Set of 6 dividers for Premier Duo™ BXCLAS4244 and Museum Collection BXTOMB4243
PYRPIN0005	Set of 6 dividers for BXTOMB4341

Polypropylene Bags

50-micron, transparent, polypropylene bags with self-adhesive flap. Offer good sealing and good optical properties.

Applications

Temporary storage for documents, books pending restoration and for the storage of objects pending filing.



Product code	Thickness microns	Size mm	Size inches	Pack qty
PYPPBG1318	50	130 x 180	5 ¹ / ₈ x 7 ¹ / ₂	100
PYPPBG0135	50	135 x 185	5 ¹ / ₁₆ x 7 ¹ / ₂	100
PYPPBG2418	50	245 x 185	9 ¹ / ₆₄ x 7 ¹ / ₂	100
PYPPBG2430	50	245 x 305	9 ¹ / ₆₄ x 12 ¹ / ₆₄	100
PYPPBG4030	50	405 x 305	15 ¹⁵ / ₆₄ x 12 ¹ / ₆₄	100
PYPPBG5040	50	505 x 405	19 ¹ / ₈ x 15 ¹⁵ / ₆₄	50
PYPPBG5070	50	505 x 705	19 ¹ / ₈ x 27 ¹ / ₄	50
PYPPBG6181	50	610 x 810	24 ¹ / ₆₄ x 31 ⁵ / ₆₄	50

Bookmark Strip

Clear, inert polyester strips, which unobtrusively hold books open for display or binding.

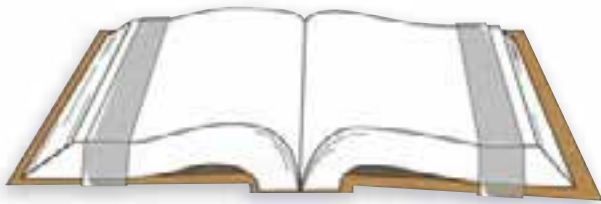

Product code	Thickness microns	Size mm	Size inches	Pack qty
SUBMST7510	75	10 x 100m	² / ₆₄	1
SUBMST7515	75	15 x 100m	¹⁹ / ₃₂	1
SUBMST7520	75	10 x 100m	⁶³ / ₆₄	1

Information

Polyester Film Conversion

Gauge	mil	Inches	Micron
48	0.5	0.00048	12
200	2	0.002	50
300	3	0.003	75
400	4	0.004	100
500	5	0.005	125

Timecare® Polyester Rolls and Cut Sheets

Polyester Rolls - Types 1 and 2

Pure Polyester in roll form for custom-made, crystal clear protective pockets and covers in large format. It can be welded using a variety of machines available in this catalogue or sewn by machine or fixed with tapes. It can also be combined with acid-free board to give a rigid backing.

CXD Timecare® Crystal Polyester Type 2

Now available on rolls, the new easy-weld polyester from Conservation By Design. This is a special polyester which CXD have introduced for making its Timecare® Crystal Type 2 Album Pages and flat-weld pockets. Type 2 polyester has the advantage that it can be welded at a lower temperature and with a wider fusion band than regular Type 1 polyester. It can be welded with any of the machines listed in this catalogue and can be spot-welded with tacking irons. It is also easier to weld to paper, board, non-woven polyester or polyethylene.

Thickness microns: 100

Applications

- Manuscripts
- Prints and drawings
- Maps
- Photographic prints
- Posters
- Comics
- Wallpaper and works of art on paper

 [Linked Products: Timecare® Ringbinder Boxes etc. p17; Curateur and Criss Cross and Sonic Welder p174.](#)



Product code	Description	Thickness microns	Size mm	Size inches	Pack qty
PYAPRS1210	Melinex® S	12	1524 x 100m	60 x 3937 ¹ / ₆₄	1
PYAPRS1245	Melinex® S	12	1526 x 45m	60 ⁶ / ₆₄ x 1771 ¹ / ₂	1
PYAPRL1210	Polyester	12	1524 x 100m	42 ¹ / ₆₄ x 3937 ¹ / ₆₄	1
PYAPRO1001	Melinex® O	100	1067 x 100m	40 x 3937 ¹ / ₆₄	1
PYAPRO1002	Melinex® O	100	1016 x 20m	40 x 787 ¹ / ₆₄	1
PYAPRO7510	Melinex® 401	75	1016 x 100m	40 x 3937 ¹ / ₆₄	1
PYAPRO7520	Melinex® 401	75	1016 x 20m	40 x 787 ¹ / ₆₄	1
PYAPRD5020	Melinex® 401	50	1016 x 20m	40 x 787 ¹ / ₆₄	1
PYTTRL1002	Timecare® Crystal Type 2	100	1016 x 100m	40 x 3937 ¹ / ₆₄	1

Polyester Cut Sheets

Transparent cut sheets for the protection of paper documents.

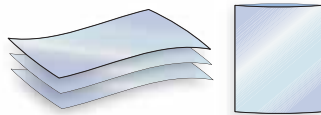

Pure Polyester in cut-sheet form for custom-made crystal clear protective pockets and covers in large format. It can be welded using a variety of machines available in this catalogue or sewn by machine or fixed with tapes. It can also be combined with non-woven polyester or with acid-free board to give a rigid backing.

Applications

- Manuscripts
- Prints and drawings
- Maps
- Photographic prints
- Posters
- Comics
- Wallpaper and works of art on paper

 *Linked Products: Timecare® Ringbinder Boxes p17; Polyester Welder p174. Original Curateur Criss Cross, Polyester Edge Welder p174*

Product code	Description	Box ref.	Thickness microns	Size mm	Size inches	Pack qty
PYPOCS0040			75	101 x 152	4 x 6	100
PYPOCS0005			75	106 x 106	4 ¹ / ₆ x 4 ¹ / ₆	100
PYPOCS0006	A6		75	117 x 159	4 ⁵ / ₈ x 6 ¹ / ₄	100
PYPOCS0700	A5+	-	75	155 x 230	6 ¹ / ₈ x 9 ¹ / ₁₆	100
PYPOCS0900		P1	75	212 x 262	8 ³ / ₈ x 10 ⁵ / ₁₆	100
PYPOCB0800	A4+	-	75	231 x 357	9 ¹ / ₈ x 14 ¹ / ₁₆	100
PYPOCS0800	A4+	-	75	231 x 313	9 ¹ / ₈ x 12 ⁵ / ₁₆	100
PYPOCS2531	A4		75	250 x 310	9 ⁷ / ₃₂ x 12 ¹³ / ₆₄	100
PYPOCS1000		P2	75	262 x 313	10 ¹ / ₁₆ x 12 ⁵ / ₁₆	100
PYPOCS1500	A3	-	75	307 x 430	12 ¹ / ₁₆ x 16 ¹⁵ / ₁₆	100
PYPOCS1200		P3	75	314 x 414	12 ³ / ₈ x 16 ⁵ / ₁₆	100
PYPOCS0041		P4	75	414 x 517	16 ⁵ / ₁₆ x 20 ³ / ₈	100
PYPOCS1600	A2	-	75	430 x 604	16 ⁵ / ₁₆ x 23 ³ / ₄	100
PYPOCS5166	A2		75	510 x 660	20 ⁵ / ₆₄ x 25 ⁴⁹ / ₆₄	100
PYPOCS0014		P5	75	516 x 618	20 ⁹ / ₁₆ x 24 ⁹ / ₁₆	100
PYPOCS0017		-	75	608 x 855	23 ¹ / ₁₆ x 33 ¹¹ / ₁₆	100
PYPOCS0017			100	710 x 1010	27 ¹ / ₆₄ x 39 ⁹ / ₆₄	50
PYPOCS7217	APOS		75	763 x 1016	30 x 40	100

Other cut sheet sizes are available.

Polypropylene Sheets

Rigid, strong and ideal for covers and making map and plan folders.

Applications

- Covers
- Map and plan folders



Product code	Type	Thickness microns	Size mm	Size inches	Pack qty
PYPPT7462	Opaline, clear natural	410	1040 x 1473	40 ⁵ / ₁₆ x 58	25

Storage and Transportation Bags

Costume Bag

Unbleached, washable drill cotton custom-made bags with a polyester identity label sewn onto the outer cover and Velcro® fastener down one long side.

A narrow top opening is provided through which the end of a hanger may be inserted to enable vertical storage. Sizes may be mixed to take advantage of bulk rates. *Made-to-measure service available, minimum run per size 10.*



SUCBAG1219

Product code	Description	Size mm	Size inches	Pack qty
SUCBAG1219	Drill Cotton-Buff	1219 x 610	47 ³ / ₆₄ x 24 ¹ / ₆₄	10
SUCBAG1291	Drill Cotton-Buff	1219 x 915	47 ³ / ₆₄ x 36 ¹ / ₃₂	10
SUCBAG1524	Drill Cotton-Buff	1524 x 610	60 x 24 ¹ / ₆₄	10
SUCBAG1591	Drill Cotton-Buff	1524 x 915	60 x 36 ¹ / ₃₂	10
SUCBAG1891	Drill Cotton-Buff	1829 x 915	72 ³ / ₆₄ x 36 ¹ / ₃₂	10

Map and Banner Bag, Calico

Low-technology but very effective, stitched, calico map/banner bag, with cotton tape string pull. Designed to protect rolled titles maps, plans and banners; they keep out dust and dirt but allow the object to breathe through the pores of the cloth weave.



Product code	Description	Size mm	Size inches	Pack qty
SUMAPB6583	Buff	914 x 241	35 ⁴⁹ / ₆₄ x 9 ³ / ₆₄	1
SUMAPB6584	Buff	1067 x 241	42 ¹ / ₆₄ x 9 ³ / ₆₄	1
SUMAPB6585	Buff	1219 x 241	47 ³ / ₆₄ x 9 ³ / ₆₄	1
SUMAPB6586	Buff	1575 x 241	62 ³ / ₆₄ x 9 ³ / ₆₄	1
SUMAPB6587	Buff	1829 x 241	72 ¹ / ₆₄ x 9 ³ / ₆₄	1
SUMAPB6588	Buff	2134 x 241	84 ¹ / ₆₄ x 9 ³ / ₆₄	1
SUMAPB6589	Buff	2438 x 241	95 ⁴⁹ / ₆₄ x 9 ³ / ₆₄	1

CORROSION INTERCEPT® Film and Bags

CORROSION INTERCEPT® (CI) is a revolutionary, patented technology which uses semi-conductor technology to transform plastics into a protective reactive barrier against corrosive gases, fungus and bacteria. With built-in saturation indicator.

Supplied in ready-made bags either plain or with zip closure. Special bags can be made to order. CORROSION INTERCEPT® can be welded using one of the CXD Criss Cross welders that can be found in the Equipment and Accessories section of this catalogue. Please request a technical data sheet for more information



SUCIZB Bags



SUCIFM Roll

Product code	Description	Size mm	Size inches	Pack qty
SUCIFM0500	CI film roll	1219 x 152m	47 ³ / ₆₄ x 5984 ¹ / ₄	1 Roll
SUCIFM1219	CI film roll	1219 x 10m	47 ³ / ₆₄ x 393 ¹⁵ / ₆₄	1 Roll
SUCIOB0406	Bags - open top	152 x 102m	5 ⁴³ / ₆₄ x 4015 ³ / ₄	1
SUCIOB0609	Bags - open top	152 x 229m	5 ⁴³ / ₆₄ x 9015 ³ / ₄	1
SUCIOB0810	Bags - open top	203 x 254	7 ⁶³ / ₆₄ x 10	1
SUCIOB1012	Bags - open top	254 x 305	10 x 12 ¹ / ₆₄	1
SUCIOB2024	Bags - open top	508 x 610	20 x 24 ¹ / ₆₄	1
SUCIZB0810	Bags - zipper-style top	203 x 254	7 ⁶³ / ₆₄ x 10	1
SUCIZB1012	Bags - zipper-style top	254 x 305	10 x 12 ¹ / ₆₄	1

 *Linked Products: see CD Cases p19; CXD Ringbinder Boxes p17. Corrosion protection products p78, 80 and 106.*

Storage and Transportation Bags

Big Yella™ Bag and Transfolio™ Bag

Designed to carry large or bulky items, a heavy-duty, reinforced PVC material with strap and buckles. Two label windows, shoulder strap and carry handles.

The bright yellow, heavy-duty, reinforced PVC material is extremely strong and enables the Transfolio™ to be easily recognisable, screaming out for attention and making it virtually impossible to lose.

Two styles available - conventional 'pocket' bag or Transfolio™ four-flap style.

This bag requires a lightweight stiffening panel when in use. Gatorfoam®/mountboard/EB Fluted board is ideal for this purpose.



Visifiles™

Features

- Available in four standard sizes
- Adjustable shoulder strap
- Carrying handle on both sides so that the bag can be carried comfortably by one or two people
- Heavy-duty straps, plastic buckles - pull tension type
- 2 label windows for identification, delivery notes etc.
- Visifile™ transparent folders are available in sizes to fit the Big Yella™ bag

Transfolio™ bags can be made up to special order in other materials and colour.

Conservation By Design Limited are happy to quote for other sizes or any other special requirements.

Product code	Description	Size mm	Size inches	Pack qty
SUBIGY0420	A2 Bag	700 x 560	27 ⁷ / ₁₆ x 22 ⁷ / ₁₆	1
SUBIGY0615	A1 Bag	950 x 700	37 ¹³ / ₃₂ x 27 ⁷ / ₁₆	1
SUBIGY0841	AO Bag	1270 x 950	50 x 37 ¹³ / ₃₂	1
SUBIGY1000	BO Bag	1550 x 1050	61 ¹ / ₃₂ x 41 ¹¹ / ₃₂	1
SUBIGY4060	Transfolio™ Four-flap Bag	1000 x 1500	39 ³ / ₈ x 59 ¹ / ₁₆	1



AO bag shown: SUBIGY0841



Oxygen and Moisture-Barrier Bags and Films

CXD Low-Barrier, Transparent Vacuum Bags

Short-term, vacuum-packing pouches

Suitable for disaster-recovery processes such as the 'Squelch Drying' system for water-damaged books and materials developed by CXD for use with the ArchiPress™ and vacuum-sealing machines.

These low-cost bags are supplied especially for use with the method of drying waterlogged or damp material identified by Stuart Welch and developed with the assistance of Dr. Nicholas Hadgraft. The pouches do not need the same level of barrier for this application as the ArchiPress™, Mitsubishi PTS or Aluminium foil bags since the vacuum is only required for a short time. It was discovered that vacuum-sealed wet objects quickly transfer moisture to any dry, absorbent material, such as blotting paper or newspaper, until the object and the blotter are equally moist. At this stage the bag is opened, the wet blotter is replaced by dry blotter and the bag is vacuum sealed again. This process is repeated until the object, book etc. reaches the required dryness. The technique has proved remarkably effective with books because the bindings are held under pressure, which means they dry without any swelling, fracture or distortion of the binding structure. While held in the vacuum pouches the wet material is unaffected by mould growth because of the lack of oxygen. If wet material is to be stored for longer periods use the ArchiPress™ High-Barrier Pouches.

Applications

- Suitable for disaster-recovery process using the ArchiPress™ vacuum-packing machines.

Linked Products: Vacuum-Packing Machines p168; Blotting Paper p101; Oxygen Scavengers p180.

Product code	Thickness mm	External size inches	External size mm	Internal size inches	Internal size mm	Special min qty
SULBVB0025	20/70	9 ³ / ₄ x 15 ³ / ₄	250 x 400	9 ¹ / ₄ x 16 ¹ / ₄	235 x 387	100
SULBVB0030	20/70	11 ¹ / ₄ x 17 ¹ / ₄	300 x 450	11 ¹ / ₄ x 16 ¹ / ₄	285 x 425	100
SULBVB0045	20/70	17 ³ / ₄ x 23 ¹ / ₂	450 x 600	17 ³ / ₄ x 23	438 x 585	100
PYLBVB1030	20/80	40 ⁷ / ₈ x 52 ³ / ₈	1030 x 1330	10 ³ / ₃₂ x 51 ¹ / ₈	1015 x 1317	50

Smaller sizes available on request.

Escal Neo™ RP System, Ceramic-Deposited, Gas-Barrier Film

A transparent, high-moisture and oxygen-barrier film for use with RP sachets

Escal Neo™ for the protection of cultural properties supplied in single-sheet rolls or double-sheet tube rolls. The material is a ceramic-deposited super-barrier film developed especially for use with the Mitsubishi RP System (p180). The user can unroll and cut the Escal Neo™ film to a desired length and seal with a heat-sealer. Each Escal Neo™ film roll includes a continuous data-entry space with a white writable background.

Escal Neo™ has an outstanding ability to keep out moist air. It is therefore very useful not only for the preservation of damp wooden artefacts, but also for all other conservation or storage purposes. On the other hand, the RP Type A (RP-A) agent works to keep the inside atmosphere of a container very dry, therefore it is not appropriate for conservation or storage of small quantities of paper/textile materials or wooden artefacts, which require a more normal RH.

Mitsubishi have developed another type called RP-K which does not affect the moisture in a container and which therefore can be used for non-metallic artefacts. This product is mainly used to protect photographs, films and dyed products from discolouring and fading. It also prevents mildew and insect-damage to paper, textile materials and wooden artefacts.

Product code	Size mm	Pack qty
SUESNE7754	W160 external (140 internal)	Per metre length
SUESNE7755	W240 external (220 internal)	Per metre length
SUESCA0480	W480 external (460 internal)	Per metre length
SUESNE7756	W1000	Per metre length

ArchiPress™, High-Barrier Vacuum Pouches

ArchiPress™ vacuum pouches are made from a five-layer, co-extrusion, plasticiser-free, pure polyester, pure polyethylene and a special gas-barrier layer. For use with CXD ArchiPress™ 1000, 1500, 1900 and 2900 and other vacuum-packing machines.

The impermeability of the pouch inner layer to oxygen, nitrogen and water ensures safe and strong long-term storage. The vacuum storage period depends on the contents of the pouches and tests indicate the vacuum will be maintained in excess of 10 to 25 years. The Dutch Institute for Scientific Research recommends a vacuum pressure of 100mbar for sealing.

Applications

- Museum and archive storage
- Books
- Papers
- Film, photographs
- Textiles
- Object
- Herbarium
- Geological specimens

Disaster management storage of wet material to prevent mould growth. For use with Ageless ZPT® Oxygen-Absorbing Sachets.

NB: Although RP-A and RP-K can be used with these bags to remove oxygen, their moisture permeability will not maintain a stable humidity within the bag.

NB. Standard ArchiPress™ Pouches are supplied with the ArchiPress™ logo printed on one side of the pouch. Your own information or company logo may be printed on the pouches by request, minimum order 25,000.

 **Linked Products:** RP Ageless p180; Vacuum-Packing Machines p168.

Product code	Type	Thickness microns	Size mm	Size inches	Pack qty
SUAPVP0007	(150,200,300)	92	250 x 400	15¼ x 9¾	1
SUAPVP0280	(150,200,300)	92	280 x 440	17½ x 11	1
SUAPVP0540	(300)	92	790 x 540	31½ x 21¼	1
SUAPVP0560	(300)	92	485 x 560	19½ x 22½	1

For use with ArchiPress™ 150, 200 and 300 vacuum-packing machines.

PTS-Grade, Very High-Barrier, Pre-Formed Pouches

The PTS material is more permeable to water vapour than Escal Neo™. Using the RP System™ Escal Neo™ can be expected to perform well for several years whereas the PTS material may only be expected to perform well for a year or less. Nevertheless its performance still far exceeds other transparent, non-metal foil barrier pouches for moisture permeability. Available in a range of pre-formed bags in a wide range of sizes suitable for use with a Criss Cross Impulse heat-sealer or a vacuum-sealing machine.



Criss Cross Welder

 **Linked Products:** Heat-Sealing Equipment p173 and Vacuum-Sealing Machines p168; Criss Cross Welder p167.

Product code	External size mm	Size inches	Pack qty
SUPTSP2029	(ExtW)220 x (L)300	(ExtW)8¾ x (L)3¾	1
SUPTSP3349	(ExtW)350 x (L)500	(ExtW)13¾ x (L)19¾	1
SUPTSP3861	(ExtW)400 x (L)620	(ExtW)15¾ x (L)24¾	1
SUPTSP7884	(ExtW)800 x (L)850	(ExtW)31½ x (L)33¾	1

For vacuum-packing machines - see the ArchiPress™ Vacuum-packing machines in the Equipment section page 168.

Reactive Intercept® Barrier System (RIBS) Foil

Moisture and oxygen-barrier film with off-gassing intercepto.

Re-usable packaging system with permanent electrostatic protection and a self-contained de-ionizer for corrosive gases.



The outer side of the film is carbon conductive polymer, whilst the inside layer is CORROSION INTERCEPT® which prevents the ingress of moisture; it also neutralises atmospheric pollutants and oxidising gases.

The construction of this high-specification material combines an outer layer of tough polypropylene with an aluminium foil and an interior layer of CORROSION INTERCEPT®. This makes the material highly durable and, when sealed, the contents are cocooned within an environment that is impervious to moisture, oxygen, atmospheric pollutants and oxidising gases. When sealed (preferably with partial vacuum), this rapidly produces a micro-climate within the bag that is dry and free of atmospheric corrosive gases.

Unlike traditional scavengers, such as charcoal and micro-sieves, the inner layer of Intercept does not simply trap gases and pollutants, it reacts with and neutralises them permanently. The material was initially developed for use in aerospace and data storage where material off-gassing is a major concern, so it has been designed to be ultra-low off-gassing and is ironically very clean. The CORROSION INTERCEPT® layer is inherently anti-static and also acts as a passive bactericide fungicide.

Applications

Storage of:

- Photographs and film
- Silver
- Copper
- Brass
- Paper
- Textiles
- Framing and artwork



RIBS foil can be used as a proactive barrier against pollutants and moisture

Product code	Description	Size mm	Size inches	Pack qty
SURIBS1219	RIBS Foil MVTR, Roll.	1219 x 10m	47¾ x 393¾	1 Roll

Mitsubishi Aluminium Foil Pouches

The pouches are a complex of plastic and aluminium foil. The inner layer being a heat-sealable polyethylene. The aluminium foil offers the best form of oxygen and moisture-barrier but, being opaque, the contents cannot be observed.

Product code	Size mm	Size inches	Pack qty
SUMALU2029	285 x 200	11¼ x 7¾	1
SUMALU3349	330 x 490	13 x 19¾	1
SUMALU3861	380 x 610	14¾ x 24	1

Moistop Barrier foils

Barrier foils are a 3 or 4-ply laminate consisting of polyester, aluminium foil and polyethylene, which are used to prevent corrosion and moisture damage. The key to the product is the aluminium foil layer which acts as a gas barrier making the laminate a form of flexible 'tin can'. Often used for lining showcases as a barrier against gas emissions from wood or MDF board. The benefits of using Barrier Foil are as follows.

Benefits

- Up to 80 times more effective at preventing water-vapour ingress than polythene
- Substantial reduction in desiccant usage offers overall savings
- Resistant to physical damage, UV, acid, alkalis, chemical and biological degradation
- Saves costs on outer pack quality, case linings and preservatives
- Much quicker to heat-seal with better seal integrity
- Approved to UK, DEF, STAN 81/41 and USA MILB131H

Technical Information

- Basic Weight: 112gsm Nominal EN 22 286
- Sealing Tensile Strength: Approx 35-40 N/15mm
- Water-Vapour Permeability: <0.05 gms/m²/24 hours – DIN 53 122
- Oxygen Transmission: 0.001 cc/m²/24hrs – DIN 53 380
- Temperature Resistance: -40°C to +80°C

Construction

- Polyester Film: 12 microns
- Polyethylene Bonding Layer: 16 microns
- Aluminium Foil: 7 microns
- Polyethylene Bonding Layer: 16 microns
- White LDPE/LLDPE Film: 70 microns
- Total Thickness: 121 microns
- Commercial Trade Tolerances: ± 5% Typical

Product code	Description	Size mm	Size inches	Pack qty
SUMSPP5100	Roll PP005	W 1000 x 200m	39 ¹ / ₁₆ x 7874 ¹ / ₆₄	1 Roll
SUMSPP5125	Roll PP005	W 1250 x 200m	49 ¹ / ₃₂ x 7874 ¹ / ₆₄	1 Roll
SUMSPP5150	Roll PP005	W 1500 x 200m	59 ¹ / ₁₆ x 7874 ¹ / ₆₄	1 Roll

Aluminium Vapour-Barrier Complex

Humidity, polluting gases and dust are the main factors capable of damaging art objects. This industrial product is a composite material based on aluminium foil made into a complex lamination of polyester and polyethylene. It can be heat-sealed with a CXD Criss Cross welder to ensure highly efficient moisture protection of box interiors for artwork or museum objects during shipping. It is also useful for making envelopes and dust covers and as a moisture-barrier in picture frames. It is commonly specified for covering and encapsulating wooden surfaces in showcases in order to act as a barrier against acetic acid and other corrosive gases emanating from the wood. It can be made into pouches suitable for vacuum-packing or anoxic storage and pest-eradication treatments.

Product code	Weight gsm	Size mm	Size inches	Pack qty
SUALUM0001	142	1500 x 100m	59 ¹ / ₁₆ x 3937 ³ / ₆₄	1 Roll
SUALUM0002	142	1500 x 100m	59 ¹ / ₁₆ x 3937 ¹ / ₆₄	1 Roll
SUALUM0003	270	1500 x 100m	59 ¹ / ₁₆ x 3937 ³ / ₆₄	1 Roll
SUALUM0004	270	1500 x 100m	59 ¹ / ₁₆ x 3937 ¹ / ₆₄	1 Roll

Linked Products: Criss Cross Heat Sealers p167, Vacuum-Packing Machines p168, Monitoring Equipment p192, Silica Gel p190, Oxygen Scavengers p180.

Timecare® Acid-Free Mounting Paper Inserts for Album Pages/Pockets

Heritage Archival pHotokraft™ paper 230gsm cut sheets designed to fit inside Timecare® polyester pockets and album pages. Items can be mounted on these sheet inserts to create an archive system, diary or scrapbook. Pages can be annotated and labelled.

Specifications

See Heritage Archival pHotokraft™ Specification on previous page (84)

Linked Products: Polyester Pockets p69; V Mounts p137; Gloves p215; Pigma Pens p141 and HB Pencils p141; Tapes p132; Ringbinder Boxes p17.

Product code	Size	Material	Weight gsm	Size mm	Size inches	Pack qty
PACSAS0148	A5	Neutral Grey	230	150 x 228	9 x 5	50
PACSAS0225	A4	Neutral Grey	230	225 x 308	8 x 12	25
PACSAS0297	A3	Neutral Grey	230	422 x 307	16 x 12	50
PACSAS0371	Foolscap	Neutral Grey	230	371 x 251	14 x 9	50
PAHPKD0601	A5	White	230	150 x 228	9 x 5	50
PAHPKD0801	A4	White	230	225 x 308	8 x 12	25
PAHPKD0602	A5	Old Grey Ivory	230	150 x 228	9 x 5	50
PAHPKD0802	A4	Old Grey Ivory	230	225 x 308	8 x 12	25
PAHPKD0603	A5	Duke Parchment	230	150 x 228	9 x 5	50
PAHPKD0803	A4	Duke Parchment	230	225 x 308	8 x 12	25



Timecare® Mounting Sheets shown in Timecare® Library Ringbinder Box with Timecare® Polyester Album Pages



Papers, Materials and Boards



Papers

- Archival Paper
- Photographic and High-Purity Storage Paper
- European Handmade Paper
- Japanese Paper Collection
- Tissue and Lightweight Papers
- Blotting Paper
- Papermaking and Leafcasting Fibres



Materials

- Silicone Release, Synthetic Non-woven and Heat-Set Material
- Synthetic Materials and Heat-Set Lamination
- Corrosion Protection and Barrier Materials



Boards

- Handmade Bookbinders Board and Millboard
- Mounting Boards
- Support Boards and Backing Boards



Papers, Materials and Boards

Traditional papermaking

Paper was invented in China around 200 years BC. Introduced via Korea, some 800 years later, production started in Japan. In 800 AD the secret of papermaking was learned by the Arabs who brought it to Europe 300 years later circa 1100 AD. From that time it spread through Europe reaching England in the 16th century.

Few other inventions have had such a lasting influence on culture and daily life as paper. Over its long history paper has been made for many purposes and, with the exception of Chinese, Korean and Japanese paper used for relining scrolls, it is perhaps only since the 1960s in Europe and North America that paper has been made specifically with Conservation and Preservation in mind, following a growing awareness of the need to preserve paper-based and photographic collections.

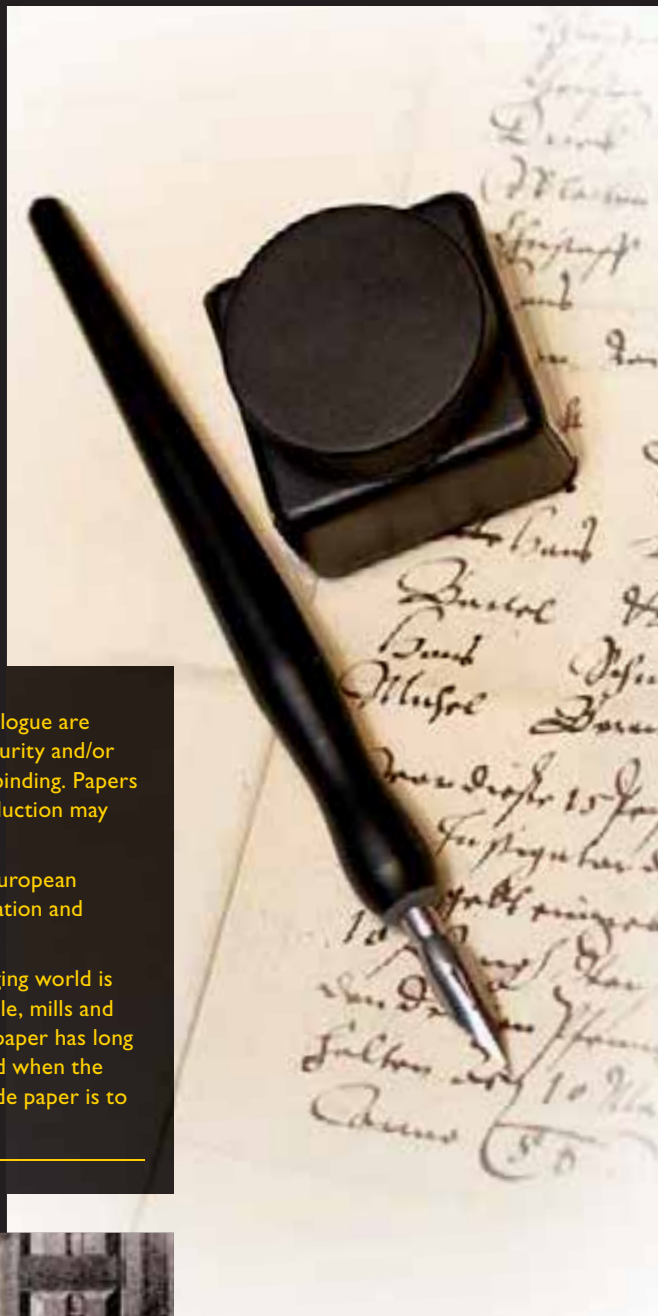

The majority of the papers in the Conservation By Design (CXD) catalogue are exclusive and have been made to our specification – usually for their purity and/or their strength – specifically for conservation repair, storage and bookbinding. Papers which have been specified simply as acid-free for use in graphic reproduction may not necessarily meet these requirements.

Shown in this catalogue is a selection of the very finest Oriental and European handmade and machine-made paper for a variety of specialist conservation and preservation applications.

Maintaining handmade and machine-made traditional papers in a changing world is becoming increasingly difficult because uses are changing and the people, mills and equipment needed to produce them are disappearing. Machine-made paper has long tried to imitate handmade paper, but we may now be entering a period when the only economical way to produce papers that match early machine-made paper is to make it by hand.

18th-century papermaking by hand from The Gentleman's Magazine, from the 1760s, showing a Hollander beater on the left, the waterwheel (centre) and the vat crew forming sheets, couching sheets and slaying sheets after pressing.

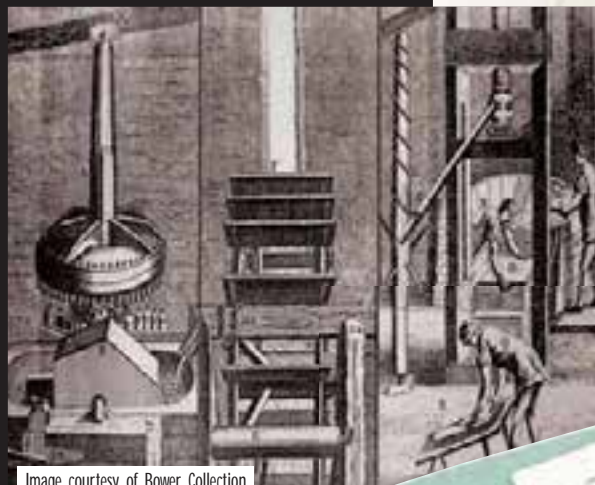
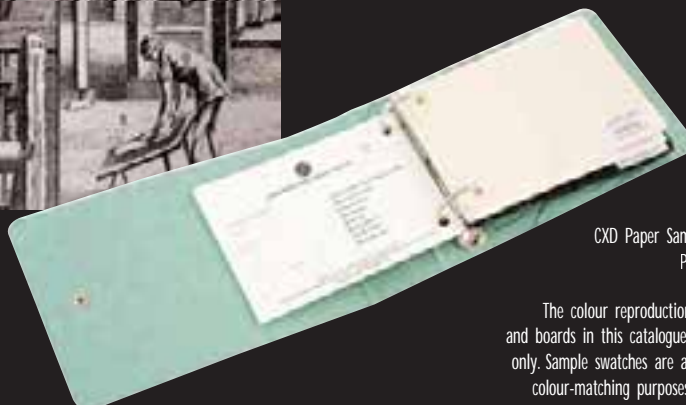

Image courtesy of Bower Collection



CXD Paper Sample Swatch
PAHPSB0003

The colour reproduction of papers and boards in this catalogue is a guide only. Sample swatches are available for colour-matching purposes from CXD.

Archival Paper

Heritage Archival pHotokraft™ – Paper

A combination of strength and purity

The new Heritage Archival pHotokraft™ papers are acid-free and lignin-free, long kraft fibre papers designed for use as conservation storage, bookbinding, long-life printing and photocopy paper. The range consists of 5 colours and is offered in 5 weights and is available in sheets and rolls.

Manufactured to the highest archival standards, these papers offer excellent die-cutting and creasing performance. They are internally and externally ‘tub’-sized which improves fold strength, resistance to water, surface-abrasion and ensures good printability. All colours are lightfast and bleed-proof and made without the use of Optical Brightening Agents (OBAs). Both 100% virgin pulp and pure clean water are used in its production.

Heritage Archival pHotokraft™ White is supplied in buffered and unbuffered versions. White is also available in 90gsm gummed tape.

Heritage Archival pHotokraft™ papers are used to produce Premier Duo™ Archival Folding Boxboard, Premier Duo™ Fluted Boxboard and Premier Duo™ Foamboard.

 *Linked Products: Folders p42; Boxes p7.*

Specifications

- pH7.5 to 9.5 (unbuffered 6.5 to 8.5) BS2924 ISO6588:1981
- Acid-free and lignin-free (ASTM D1030/ISO 302)
- Lightfast and bleed-proof pigments - min 5 BlueWool Scale test (BS1006:97 and TAPPI T475)
- Neutral AKD internal sizing, external tub-sized/starch
- Buffered (average 3%) calcium carbonate (ISO 9706:2004) (Unbuffered, no calcium carbonate added)
- High percentage long kraft fibres
- Alpha Cellulose above 87%
- Reducible Sulphur less than 0.8 parts per million (0.0008%) (TAPPI T406)
- No added OBAs
- Passes Silver Tarnish Test (ASTM D2043)
- Passes PAT (Photographic Activity Test) (ISO 18916)
- Weights: 90, 120, 170, 230 and 350gsm



Applications

- Permanent storage (folders and envelopes)
- Long-life printing
- Photocopying
- Photographic storage (buffered and unbuffered)

Information

- Kraft = 120gsm
- Manilla = 225 - 230gsm
- Cover = 300 - 350gsm

These are common historical terms used to denote the gsm weight of the paper and not the fibre. The term Manilla probably came from the use of strong ‘Manilla Hemp’ for making folder paper. However no ‘manilla’ fibre is used to produce the Heritage Archival pHotokraft™ Paper.

Please ask for full specification sheet.



Heritage Archival pHotokraft™ Neutral Grey

NEUTRAL GREY

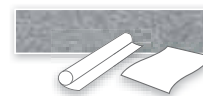

Product code	Roll/sheet	Colour	Weight gsm	Size mm	Size inches	Pack qty
PAHPKA4704	Sheet	Neutral Grey	90	840 x 1200	47¼ x 33½	125
PAHPKB4704	Sheet	Neutral Grey	120	840 x 1200	47¼ x 33½	100
PAHPKC4704	Sheet	Neutral Grey	170	840 x 1200	47¼ x 33½	100
PAHPKD4704	Sheet	Neutral Grey	230	840 x 1200	47¼ x 33½	50
PAHPKE4704	Sheet	Neutral Grey	350	840 x 1200	47¼ x 33½	50
PAHPKE5804	Sheet	Neutral Grey	350	1040 x 1473	40⅞ x 58	30
PAHPKB2704	Roll	Neutral Grey	120	1680 x 25m	66⅞ x 984¼	1
PAHPKD2704	Roll	Neutral Grey	230	1680 x 25m	66⅞ x 984¼	1
PAHPKE2704	Roll	Neutral Grey	350	1680 x 25m	66⅞ x 984¼	1

Heritage Archival pHotokraft™ Duke Parchment

DUKE PARCHMENT

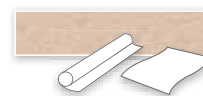

Product code	Roll/sheet	Colour	Weight gsm	Size mm	Size inches	Pack qty
PAHPKA4703	Sheet	Duke Parchment	90	840 x 1200	47¼ x 33½	125
PAHPKB4703	Sheet	Duke Parchment	120	840 x 1200	47¼ x 33½	100
PAHPKC4703	Sheet	Duke Parchment	170	840 x 1200	47¼ x 33½	100
PAHPKD4703	Sheet	Duke Parchment	230	840 x 1200	47¼ x 33½	50
PAHPKE4703	Sheet	Duke Parchment	350	840 x 1200	47¼ x 33½	50
PAHPKE5803	Sheet	Duke Parchment	350	1040 x 1473	40⅞ x 58	30
PAHPKB2703	Roll	Duke Parchment	120	1680 x 25m	66⅞ x 984¼	1
PAHPKE2703	Roll	Duke Parchment	350	1680 x 25m	66⅞ x 984¼	1

Heritage Archival pHotokraft™ White Buffered

WHITE



Product code	Roll/sheet	Colour	Weight gsm	Size mm	Size inches	Pack qty
PAHPKA0801	Sheet	White	90	(A4) 210 x 297	8¼ x 11⅞	500
PAHPKA1601	Sheet	White	90	(A3) 420 x 297	16⅞ x 11⅞	500
PAHPKA4701	Sheet	White	90	840 x 1200	33⅞ x 47¼	125
PAHPKB0801	Sheet	White	120	(A4) 210 x 297	8¼ x 11⅞	500
PAHPKB1601	Sheet	White	120	(A3) 420 x 297	16⅞ x 11⅞	500
PAHPKB4701	Sheet	White	120	840 x 1200	33⅞ x 47¼	100
PAHPKC4701	Sheet	White	170	840 x 1200	33⅞ x 47¼	100
PAHPKD4701	Sheet	White	230	840 x 1200	33⅞ x 47¼	50
PAHPKE4701	Sheet	White	350	840 x 1200	33⅞ x 47¼	50
PAHPKE5801	Sheet	White	350	1040 x 1473	40⅞ x 58	30
PAHPKA2701	Roll	White	90	1680 x 50m	66⅞ x 1968½	1
PAHPKB2701	Roll	White	120	1680 x 25m	66⅞ x 984¼	1
PAHPKD2701	Roll	White	230	1680 x 25m	66⅞ x 984¼	1
PAHPKE2701	Roll	White	350	1680 x 25m	66⅞ x 984¼	1

Heritage Archival pHotokraft™ White Unbuffered

WHITE



Product code	Roll/sheet	Colour	Weight gsm	Size mm	Size inches	Pack qty
PAHPKA4791	Sheet	White	90	840 x 1200	47¼ x 33½	125
PAHPKB4791	Sheet	White	120	840 x 1200	47¼ x 33½	100
PAHPKC4791	Sheet	White	170	840 x 1200	47¼ x 33½	100
PAHPKD4791	Sheet	White	230	840 x 1200	47¼ x 33½	50

Heritage Archival pHotokraft™ Old Grey Ivory

OLD GREY IVORY



Product code	Roll/sheet	Colour	Weight gsm	Size mm	Size inches	Pack qty
PAHPKA0802	Sheet	Old Grey Ivory	90	(A4) 210 x 297	8¼ x 11½	500
PAHPKA1602	Sheet	Old Grey Ivory	90	(A3) 420 x 297	16½ x 11½	500
PAHPKA4702	Sheet	Old Grey Ivory	90	840 x 1200	33½ x 47¼	125
PAHPKB4702	Sheet	Old Grey Ivory	120	840 x 1200	33½ x 47¼	100
PAHPKC4702	Sheet	Old Grey Ivory	170	840 x 1200	33½ x 47¼	100
PAHPKD4702	Sheet	Old Grey Ivory	230	840 x 1200	33½ x 47¼	50
PAHPKE5802	Sheet	Old Grey Ivory	350	1040 x 1473	40½ x 58	30
PAHPKC2702	Roll	Old Grey Ivory	170	1680 x 25m	66½ x 98¼	1

Heritage Archival pHotokraft™ Taupe

TAUPE



Product code	Roll/sheet	Colour	Weight gsm	Size mm	Size inches	Pack qty
PAHPKB3905	Sheet	Taupe	120	700 x 1000	27½ x 39½	125
PAHPKB4705	Sheet	Taupe	120	840 x 1200	33½ x 47¼	100
PAHPKC3905	Sheet	Taupe	170	700 x 1000	27½ x 39½	125
PAHPKC4705	Sheet	Taupe	170	840 x 1200	33½ x 47¼	100

Timecare® Acid-Free Mounting Paper Inserts for Album Pages/Pockets

Heritage Archival pHotokraft™ paper 230gsm cut sheets designed to fit inside Timecare® polyester pockets and album pages. Items can be mounted on these sheet inserts to create an archive system, diary or scrapbook. Pages can be annotated and labelled.

Specifications

See *Heritage Archival pHotokraft™ Specification on previous page (84)*

Linked Products: Polyester Pockets p69; V Mounts p137; Gloves p215; Pigma Pens p141 and HB Pencils p141; Tapes p132; Ringbinder Boxes p17.

Product code	Size	Material	Weight gsm	Size mm	Size inches	Pack qty
PACSAS0148	A5	Neutral Grey	230	150 x 228	9 x 5	50
PACSAS0225	A4	Neutral Grey	230	225 x 308	8 x 12	25
PACSAS0297	A3	Neutral Grey	230	422 x 307	16 x 12	50
PACSAS0371	Foolscap	Neutral Grey	230	371 x 251	14 x 9	50
PAHPKD0601	A5	White	230	150 x 228	9 x 5	50
PAHPKD0801	A4	White	230	225 x 308	8 x 12	25
PAHPKD0602	A5	Old Grey Ivory	230	150 x 228	9 x 5	50
PAHPKD0802	A4	Old Grey Ivory	230	225 x 308	8 x 12	25
PAHPKD0603	A5	Duke Parchment	230	150 x 228	9 x 5	50
PAHPKD0803	A4	Duke Parchment	230	225 x 308	8 x 12	25

CXD Archival Rag Endleaf 100% Cotton

CREAM



100% Cotton Archival Rag Endleaf is an exceptionally high-quality paper developed primarily for conservation bookbinding, e.g. endpapers, guarding etc. It is manufactured from 100% cotton fibre. The paper has successfully been designed to meet the most stringent standards required by conservation binderies, libraries and museums. It has a smooth-wove surface, buffered with calcium carbonate and tub-sized with a pure, non-ionic, oxidised farina starch to resist fibre picking when printing and to impart extra fold surface strength to the paper. The paper is specified to pass Silver Tarnish Tests and should therefore prove useful for applications connected with certain types of photographs and manuscripts.

Standard stock colour is cream, but other colours can be produced on request, subject to minimum quantity.

Specifications

- pH8.5 (hot extract)
- Made from 100% cotton fibres
- Acid-free
- Buffered with calcium carbonate
- Tub-sized with pure, non-ionic, oxidised farina starch
- High fold-strength before and after accelerated ageing tests
- Lightfast/Blue Wool scale reading of 5
- Passes Silver Tarnish Tests



Applications

- Bookbinding (endpapers, guarding etc)
- Library conservation
- Archival storage
- Photographic storage
- Printing

Product code	Material	Weight gsm	Size mm	Size inches	Pack qty
PAAREC0080	Cream	80	813 x 1118	32 x 44	150
PAAREC0120	Cream	120	813 x 1118	32 x 44	100
PAAREC0160	Cream	160	813 x 1118	32 x 44	100

Linked Products: Superior Millboard™ p112; pHoton™ Papers p88; Cord p131, 148; Tapes p132.



Timecare® Mounting Sheets shown in Timecare® Library Ringbinder Box with Timecare® Polyester Album Pages

Timecare® Heritage Cotton Inlay Paper



This 100% Cotton Paper has been designed for 'inlaying' prints and drawings to achieve a standard size and give a handling edge other than the artwork itself. There are two main techniques for making an 'inlay' mount. The first being a tissue bridge where a hole is cut in the inlay paper slightly larger than the artwork and a thin Japanese tissue similar to 'Whisper Tissue™' joins the artwork to the inlay paper. The second being the chamfered type where a hole smaller than the artwork is cut out and the edges of the opening are sanded or feathered to create a thin and fine joining edge which will give a seamless, level join. The joint should be weaker than the artwork so that it gives way before the artwork if subjected to an extreme temperature and humidity change. The inlay paper is designed to be as docile and dimensionally stable as possible and thereby minimise any cockling and tension with the original. It is offered in Museum Cream colour to match Timecare® Heritage Cotton Core Museum Mounting Board.

Specifications

- pH8.5 (hot extract)
- Made from 100% cotton fibres
- Acid-free, lignin-free
- Buffered with calcium carbonate
- Tub-sized with pure, non-ionic, oxidised farina starch
- Lightfast/Blue Wool scale reading of 5
- Colour-matched to Timecare® Heritage 'Museum Cream' Cotton Core Mounting Board
- Other sizes and weights available on request

Applications

- Inlay paper for prints and drawings to be mounted for framing or boxing
- Archival storage

Linked Products: Timecare® Heritage Museum Board p113, Japanese Tissue p99-100, Whisper Tissue™ p99-100, Spider Tissue p99-100, Shofu Paste. p129.

Product code	Description	Colour	Size mm	Weight gsm	Pack qty
PATHIP1007	Timecare® Heritage Inlay Paper	Museum Cream	560 x 760	100	250 sheets
PATHIP1407	Timecare® Heritage Inlay Paper	Museum Cream	560 x 760	140	250 sheets

CREAM

CXD Herbarium Mounting Cartridge 100% Cotton



Specifically developed to meet the requirements of specialist museums of natural history with large Herbarium collections.

This 100% cotton mounting cartridge is acid-free and buffered with calcium carbonate.

It is gelatine-sized to impart rigidity and surface strength to allow the erasure of pencil marks and acceptance of water colour and aqueous-based inks.

Specifications

- 100% Cotton
- Lightfast to a high standard
- Gelatine-sized
- pH Neutral, 2% CaCO₃ minimum
- Free from OBAs
- Colour: Cream



Applications

- Specially developed for mounting Herbarium collections

Linked Products: Boxes p7.

Product code	Description	Colour	Size mm	Size inches	Pack qty
PAHMCC0260	Cream	220	260 x 415	10 1/4 x 16	250
PAHMCC0838	Cream	220	838 x 1143	33 x 45	100

Timecare® Heritage Museum Edition



This 100% Cotton Paper is the base laminating paper for Timecare® Heritage Museum Board. The specification of the paper not only makes it suitable for a wide range of storage and bookbinding applications but also as a fine art edition printing paper. The paper conforms to the Fine Art Trade Guild Print Standard for paper. It is offered in five colours which is unusual for a paper of this quality. The complementary range of Museum Mounting Boards in matching colours is something new to the market and offers creative possibilities to the artist and publisher.

Specifications

- pH8.5 (hot extract)
- Made from 100% cotton fibres
- Acid-free
- Buffered with calcium carbonate with the exception of TG Off White and Dull White
- Tub-sized with pure, non-ionic, oxidised farina starch
- High fold strength before and after accelerated ageing tests
- Lightfast/Blue Wool scale reading of 5
- Passes recognised Silver Tarnish Tests
- Five colours
- Fine Art Trade Guild (FATG), museum-level



Applications

- Bookbinding and library conservation
- Archival storage folders
- Storage of photographs
- Fine art
- Printing
- Can be used with matching mountboard

Linked Products: Timecare® Heritage Museum Board p113,

Product code	Colour	Weight gsm	Size mm	Size inches	Pack qty
BDTHMA3301	White	550	1189 x 841	46 13/16 x 33 1/8	20
BDTHMA3303	TG Off White*	550	1189 x 841	46 13/16 x 33 1/8	20
BDTHMA3304	Dull White*	550	1189 x 841	46 13/16 x 33 1/8	20
BDTHMA3307	Museum Cream	550	1189 x 841	46 13/16 x 33 1/8	20
BDTHMA3311	Black	550	1189 x 841	46 13/16 x 33 1/8	20

*Unbuffered

The colour reproduction of papers and boards in this catalogue is a guide only. Sample swatches are available for colour-matching purposes from CXD.

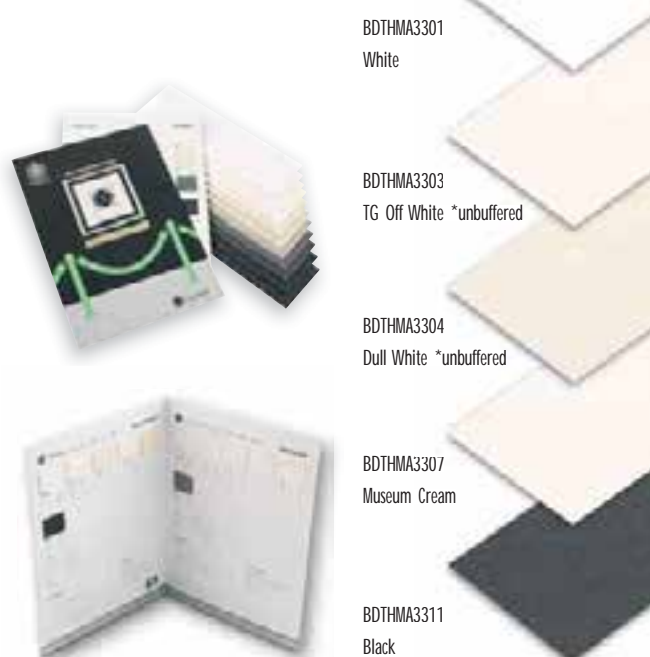

BDTHMA3301
White

BDTHMA3303
TG Off White *unbuffered

BDTHMA3304
Dull White *unbuffered

BDTHMA3307
Museum Cream

BDTHMA3311
Black

Timecare® Age Compatible™ Toned Laid

ANTIQUE DARK TONED

Timecare® Age Compatible is a 100% Cotton, gelatine-sized, laid, acid-free paper with a 2% calcium carbonate buffer. It was designed initially for the repair of antique books and papers but the compatibility of the colour and the surface-sizing makes it ideal for bookbinding and for printing facsimiles of early volumes.

Special makings for alternative weights and sizes can be undertaken to order, subject to minimum quantity requirements.

Specifications

- pH7.5
- 100% Cotton
- 2% buffered
- Gelatine-sized
- Long grain
- Laid chain lines run parallel to long edge



Applications

- Bookbinding (endpaper or repair paper)
- Printing facsimiles of early volumes

Product code	Weight gsm	Colour	Size mm	Size inches	Pack qty
PATACL0065	65	Antique Dark Toned	838 x 1143	33 x 45	200
PATACL0110	110	Antique Dark Toned	838 x 1143	33 x 45	100

Medieval Dark Toned Laid Paper

DARK TONED (CREAM) WITH FLECKS

Acid-free, mould-made paper by the specialist German papermakers Hahnemuhle, this facsimile paper has much of the character of a handmade sheet but at machine-made prices. It is available in a large sheet size which makes it useful for many conservation, bookbinding, framing and printing applications.

Specifications

- Acid-free
- Cylinder mould, machine-made paper
- Alpha cellulose from purified wood pulp
- Short grain



Applications

- Conservation
- Bookbinding
- Framing
- Printing applications

Linked Products: Boxes p7; Folders p42.

Product code	Weight gsm	Colour	Size mm	Size inches	Pack qty
PAMDTL5713	180	Dark Toned (cream) with flecks	1040 x 780	40 ¹⁵ / ₁₆ x 30 ¹¹ / ₁₆	100
PAMDTL5714	130	Dark Toned (cream) with flecks	1040 x 780	40 ¹⁵ / ₁₆ x 30 ¹¹ / ₁₆	100
PAMDTL5715	90	Dark Toned (cream) with flecks	1040 x 780	40 ¹⁵ / ₁₆ x 30 ¹¹ / ₁₆	100

Hahnemuhle Cylinder Mould-Made Laid Paper

A laid paper made from 100% chemically bleached pulp. Acid-free with an alkaline reserve. Produced on a cylinder mould machine for dimensional stability and genuine laid lines.

Specifications

- Acid-free
- Chemically bleached pulp
- No optical brighteners
- Buffered

Applications

- Printing
- Bookbinding
- Barrier paper
- Dividers
- Envelopes and folders

Product code	Weight gsm	Colour	Size mm	Size inches	Pack qty
PACMMO0002	120	Cream	1000 x 700	39 ³ / ₁₆ x 27 ⁷ / ₁₆	50
PACMMP0001	120	White	1000 x 700	39 ³ / ₁₆ x 27 ⁷ / ₁₆	50

Fabrizio Palatina Paper

IVORY

An acid-free, lignin-free paper made without optical brightening agents designed for printing but can also be used for archival storage and book binding where applicable. It is available in a classic ivory shade.

Specifications

- Acid-free
- Chemically purified wood fibre
- No optical brighteners
- Buffered



Applications

- Printing
- Bookbinding
- Barrier paper
- Dividers
- Envelopes and folders
- Photocopying

Product code	Weight gsm	Colour	Size mm	Size inches	Pack qty
PAFAPA0070	70	Ivory	700 x 1000	39 ³ / ₁₆ x 27 ⁷ / ₁₆	250
PAFAPA0100	100	Ivory	700 x 1000	39 ³ / ₁₆ x 27 ⁷ / ₁₆	250
PAFAPA0120	120	Ivory	700 x 1000	39 ³ / ₁₆ x 27 ⁷ / ₁₆	250
PAFAPA0085	85	Ivory	700 x 1000	39 ³ / ₁₆ x 27 ⁷ / ₁₆	250
PAFAPA3085	85	Ivory	297 x 420	11 ¹¹ / ₁₆ x 16 ¹ / ₂	250
PAFAPA4085	85	Ivory	210 x 297	8 ⁷ / ₁₆ x 11 ¹¹ / ₁₆	250

Linked Products: Superior Millboard™ p112; Boxes p7.

Fabrizio Copy Class I

Not a full archival specification as it contains OBAs, (Optical Brightening Agents) which give it a very high whiteness. It is, however, acid-free with an alkaline reserve to guarantee permanence - designed as a long-life (ISO 9706) photocopy paper for general use. If a higher quality and more durable paper without OBAs is required, see Heritage Archival pHotokraft™ Paper.

Specifications

- 100% bleached cellulose pulp, ECF (elementary chlorine-free)
- Certificate FSC (Certificate N° CQCOC- 00009)
- Humidity percentage: (ISO 287) between 3.5 and 5.5%
- Grammage (ISO 536): between 78 and 82gsm
- Thickness (ISO 534): between 98 and 108 microns
- Absorption (Cobb ISO 535): 30gsm
- Whiteness (ISO 2470): between 113.5 and 116.5%
- Opacity (ISO 2471) 91%
- Suitable for photocopiers, laser and inkjet printers



Product code	Description	Size mm	Size Inches	Pack qty
PAFACC0001	Copy class 1 A4	210 x 297	8 ³ / ₄ x 11 ³ / ₄	500
PAFACC0002	Copy class 1 A3	420 x 297	16 ¹ / ₂ x 11 ³ / ₄	500

Byron Weston Resistall Paper

This paper is well-known and popular with professionals in the world of Natural Sciences. A 100% cotton paper which has undergone a special treatment making it exceptionally strong when wet.

Applications

- Identification of natural history collections (specimens stored in alcohol or formaldehyde)
- Byron Weston Resistall paper maintains its dimensional stability and durability properties in these extreme conditions. Because of the wet-strength agent used this paper is not acid-free
- 120gsm

Product code	Weight gsm	Colour	Size mm	Size Inches	Pack qty
PABWPA4001	120	White	210 x 297	8 ³ / ₄ x 11 ³ / ₄	100
PABWPA2001	120	White	584 x 457	22 ³ / ₁₆ x 17 ³ / ₁₆	25

Conservation by Design classify pHoton™ as 'high purity' to distinguish between it and ordinary acid-free paper. pHoton™ is produced to a fixed quality standard for CXD by the Munktell Mill, founded in 1740 and the world's first maker of chromatography and filter paper.

pHoton™ is made on a machine that is one metre wide which only produces white paper in qualities designed for specialist filtration, medical, conservation and scientific uses.

Converted products include:

- pHoton™ Folder for prints and document storage
- pHoton™ Four-flap Enclosure for glass plates
- pHoton™ Sleeves and Pockets 'Stitch in Timecare™' for the storage of negative film. Tailored to meet most common sizes: 35mm, 60mm and 70mm film. Sleeves are sewn with cotton thread to guarantee that nothing can accelerate the ageing of the film.

The porous nature of the paper prevents the build-up of harmful gases within the enclosures, which can happen with less porous storage papers and plastic enclosures.

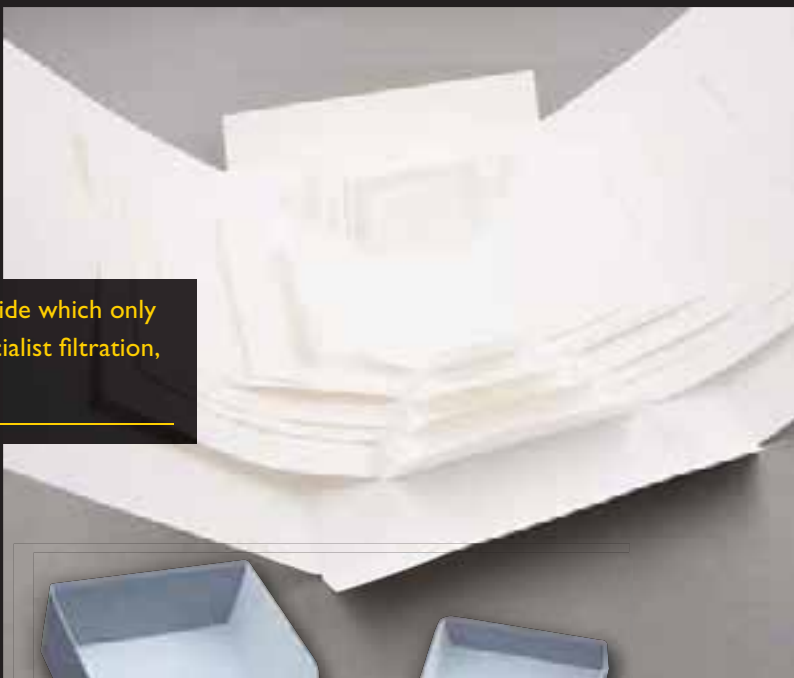

pHoton™ four-flap enclosures



Munktell Filter Papers were delivered in hand-made birch bark packages

Glass plate negative boxes: example shown of option with Plastazote® CXD Channel Panels to hold negatives vertically within a pHoton™ four-flap folder

The History of Filter Papers

The Swedish chemist J.J. Berzelius is regarded as the inventor of the first real filter paper. It was he who first started using pure waterleaf all-rag paper for the retention of precipitates in chemical analysis.

At the suggestion of Berzelius, the development and manufacture of such paper began around 1815 at J.H. Munktell's paper mill at Grycksbo. Similar production began later in England and Germany, but the 'Swedish Filter Paper' retained its leading position and its characteristics, particularly its purity, set the standard for analytical filter papers.

The paper which was handmade at the time of Berzelius, is still made at the same paper mill today, but now with the aid of modern papermaking technology.



J.J. Berzelius 1779-1848

Photographic and High-Purity Storage Paper

pHoton™ High-Purity Papers

These 100% cotton, high-purity, silver-image-safe papers and photographic storage products are produced for CXD at the Munktoll paper mill which is famous for the production of the world's first filter paper. They have been developed in collaboration with leading photographic conservators and institutes of conservation.

The pHoton™ range consists of papers made from un-sized pure cotton fibres which are virtually 100% pure alpha cellulose, containing no chemicals whatsoever and, because of this, they are probably the purest of all photographic storage papers. They are un-calendered to allow maximum airflow and prevent any potentially harmful build-up of gases that may be emitted by the photographic material stored within the enclosure. Because of their purity and porosity, these papers can safely be used for long-term storage of all kinds of photographic materials be they negatives or prints and irrespective of the photographic technique used to create them. They can, of course, be used for storing any object requiring a non-alkaline paper.

Specifications

- pH6.7
- 100% cotton fibre from pure cotton linters
- Un-sized
- Unbuffered
- Un-calendered surface from allowing maximum airflow
- Free from Optical Brightening Agents (OBAs)
- Low average ash content of 0.06%
- Passes Silver Tarnish Test
- Criterion 1: Effects on colloidal silver detector: Oxidizing influence
- Criterion 2: Effects on colloidal silver detector: Reducing influence
- Criterion 3: Staining of gelatine/photographic paper detector
- Criterion 4: Mottling of colloidal silver detector
- Reducible sulphur, as S, mg/kg, (ppm) less than 1
- Test method reducible sulphur BP and BMA Procedure No. 49 (1967)



Trace Elements

Aluminium:	Al = 29.3ppm	Iron:	Fe = 5.3ppm
Chlorine:	Cl = 15.0ppm	Sodium:	Na = 70.8ppm
Copper:	Cu = 0.4ppm	Nitrogen:	N = <2.4ppm (as nitrate)
Fluorine:	F = <5.0ppm	Calcium:	Ca = 102.0ppm
Sulphur:	S = <8.9ppm		

Linked Products: P-Boxes p12, 74; Folders p42.

Munktoll specialist, high-purity paper machine, only one metre wide



pHoton™ Roll

pHoton™, 100% pure cotton, high-purity, photographic storage papers are ideal for making large folders, linings and backings. We are offering the roll format because it is easier to store and less vulnerable to damage in handling than extra-large sheets.



Product code	Colour	Weight gsm	Size mm	Size inches	Pack qty
PHPHR04043	White	80	1000 x 100m	39% x 3937	1
PHPHR07511	White	130	1000 x 100m	39% x 3937	1
PHPHR00508	White	250	1000 x 50m	39% x 1968½	1

pHoton™ Sheets

pHoton™ cut sheets are supplied in a wide variety of photographic sizes many of which match our pHoton™ folders and Premier Duo™ Archival drop-spine 'P' boxes.

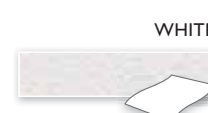

Applications

- Photographic storage – prints and negatives
- Textile storage
- Silver artefact and metal storage
- Linings, backings and wrappings
- Repairs
- Manuscripts
- Drawings

Product code	Colour	P-Box ref	Weight gsm	Size mm	Size inches	Pack qty
PHSPCS4531	White	PX	80	355 x 280	14 x 11	200
PHSPCS0080	White		80	1016 x 610	40 x 24	100
PHSPCS0210	White		80	210 x 297	8¼ x 11¼	200
PHSPCS1080	White		80	1000 x 800	38¾ x 31½	100
PHSPCS4519	White		80	90 x 120	3½ x 4¾	200
PHSPCS4520	White	P0	80	180 x 130	7¼ x 5¼	200
PHSPCS4528	White	PZ	80	240 x 180	9½ x 7¼	200
PHSPCS4529	White	P1	80	203 x 254	8 x 10	200
PHSPCS4530	White	P2	80	305 x 254	12 x 10	200
PHSPCS4532	White	P3	80	407 x 305	16 x 12	200
PHSPCS4533	White	P4	80	508 x 407	20 x 16	200
PHSPCS4534	White	P5	80	610 x 508	24 x 20	200
PHSPCS0130	White		130	1016 x 610	40 x 24	100
PHSPCM0210	White		250	210 x 297	8¼ x 11¼	200
PHSPCS0522	White	P0	250	180 x 130	7¼ x 5¼	200
PHSPCS0524	White	P1	250	203 x 254	8 x 10	200
PHSPCS0525	White	P2	250	305 x 254	12 x 10	200
PHSPCS0526	White	PX	250	355 x 280	14 x 11	200
PHSPCS0527	White	P3	250	305 x 407	12 x 16	200
PHSPCS0529	White	P5	250	610 x 508	24 x 20	200
PHSPCS1250	White		250	1000 x 800	38¾ x 31½	100
PHSPCS0250	White		250	1016 x 610	40 x 24	50
PHSPCS0528	White	P4	250	508 x 407	20 x 16	200
PHSPCS0532	White		250	500 x 650	20 x 24	200
PHSPCS0523	White	PZ	250	240 x 180	9½ x 7¼	200

Also see: Heritage Archival pHotokraft™
White Unbuffered – p84



The Moulin du Verger Paper Mill



The mill has been in existence since 1539 as a paper mill. Its current master, Jacques Brejoux, has dedicated his life to the papermakers' art and learning the secrets of the antique papermakers.

The mill produces facsimile paper ranging from the medieval period to the 18th century. Available un-sized, internal neutral-sized or gelatine tub-sized.

In addition to the stock range, special makings are undertaken to customers' requirements including Islamic-style repair paper. The Mill also produces paper for fine art and limited-edition printing.



In 2008 Jacques fulfilled a lifetime's ambition to make a medieval wooden stamper or 'maillet' in French. This was to prove that rags and fibres beaten by 'stampers' gave superior fibre bonding and therefore greater strength.

This development was brought about following the first papermaking and bookbinding summer school run by Jacques Brejoux and Christopher Clarkson – conceived and organised by Conservation By Design in 2007.

Christopher Clarkson was teaching the making of limp paper covers in the style of early Italian Renaissance bindings that so impressed him in 1966 when working to salvage books in the aftermath of the Florence Flood.

These simple bindings survived the deluge better than the vellum or leather bindings and he hoped to replace lost covers with a paper of similar quality. However he was unable to find a paper anything like the quality and strength of the Renaissance papers.

The bringing together of Christopher Clarkson and Jacques Brejoux at the Moulin Du Verger led to a research project to produce the long sought-after paper Christopher had been looking for.

Jacques had produced good quality paper on his old 'Hollander' beater but felt the only way to achieve a comparable quality to the early Italian papers was to beat the rags using 'stampers', which would open the fibres and create more links than could be created on the Hollander which is faster but has a tendency to cut the fibres.



After a substantial investment of cash and time, he had the 'stampers' up and running for the subsequent course in September 2008. Paper which has since been made using pulp beaten on the 'stampers' has proved to be stronger and has met with the approval of Christopher Clarkson.

After hearing about this project Timothy Barratt, research scientist and paper specialist at the University of Iowa 'Center for the Book', arranged for Jacques Brejoux to make a workshop and lecture tour of North America. He presented a paper on the 'stamper project' at the meeting of The Friends of Dard Hunter in October 2010.



In 2007 Conservation By Design organised the first of a series of courses in papermaking and limp paper binding with Jacques Brejoux (top) and Christopher Clarkson (middle far right). This led to the building and installation of the wooden stampers (above) used to create the MVM and CC cover papers. It is probably the first step backwards seen in papermaking!

Christopher Clarkson demonstrating a limp paper cover to Jane Giscombe at the 2007 cover paper workshop. Following the course Jane very kindly helped fund the building of the 'stampers'.

European Handmade Paper

Moulin du Verger Handmade Paper Sample Book

A beautiful hand-bound collectors' item containing different samples of these unique handmade papers and boards.



The colour reproduction of papers and boards in this catalogue is a guide only. Sample swatches are available for colour-matching purposes from CXD.

Product code	Colour	Pack qty
PAMVSB0001	Various	1

Moulin du Verger 100% Raw Flax and Linen Fibre



These handmade 'half stuff' sheets or part-beaten sheets are made from raw flax or linen plant fibre. They are used for blending with cotton pulp in the leafcasting repair process.

The colour reproduction of papers and boards in this catalogue is a guide only. Sample swatches are available for colour-matching purposes from CXD.

Specifications

- Made from raw flax or linen plant fibres

Applications

- Bookbinding
- Conservation
- Leafcasting and spot pulp repair

Product code	Description	Material	Weight gsm	Size mm	Size inches	Pack qty
PALCHM7017	Moulin du Verger handmade paper - raw flax/linen	Rough flax	250	600 x 500	23 3/8 x 19 1/8	1



Moulin du Verger de Puymoyen

The papers are dried by hanging over rope in the drying loft. They are then gelatine-sized, pressed, dried and pressed again. This process is very labour-intensive, but results in a paper of rare beauty and functionality.

Moulin du Verger Gelatine-sized MVM Medieval-Style, Wooden Stamper-Beaten Paper

ANTIQUE LIGHT TONED



The new range of Moulin du Verger 'Laid' repair and binding papers are made with old rags (at least 70 years old). They have exceptional strength because of the use of traditional stampers for beating the fibre which preserves the fibre length, resulting in a supple and elastic sheet, which is well beaten and has an even look-through. Moulin du Verger papers are not forced-dried to be flat. They are all hung to dry over ropes in the paper loft - 'loft-dried'. This allows them to dry naturally which is beneficial when repairing antique papers produced in the same way. Force or heat-dried paper is more likely to react differently to the old paper under climate changes and could cause damage.

Specifications

- Made from 70-year-old rags
- Gelatine tub-sized

Applications

- Bookbinding
- Printing
- Writing
- Drawing
- Watercolour
- Conservation

Product code	Colour	Weight gsm	Size mm	Size inches	Pack qty
PAFPMV0030	Antique light toned	30	440 x 560	17 3/16 x 22 1/16	1
PAFPMV0070	Antique light toned	70	440 x 560	17 3/16 x 22 1/16	1
PAFPMV0090	Antique light toned	90	440 x 560	17 3/16 x 22 1/16	1



Jacques Brejoux checking the rag pulp being beaten in the stampers



Didier Navarot cutting rags at the Moulin du Verger

Moulin du Verger – CC2 Pasteless Cover Paper

ANTIQUÉ LIGHT TONED



A single-ply, heavyweight paper made from hemp and linen textiles, retted and beaten with wooden stampers; designed to a quality standard set by Christopher Clarkson and tested by leading book conservators. The papers have exceptional strength due to the use of traditional stampers for beating the fibre which preserves the fibre length and creates better links resulting in a supple and elastic sheet.

The price of this special paper should be compared to Parchment rather than a normal heavyweight paper.

Specifications

- Made from hemp and linen textiles
- Gelatine or un-sized

Applications

- Limp paper bindings
- Creative bookbinding
- Watercolours and drawings

 *Linked Products: Moulin du Verger, multi-layer Renaissance Cover Paste Board p91-93, Boards section p108.*



Christopher Clarkson at his sewing frame using the CC2 Pasteless Cover Paper



Moulin du Verger
Foolscape watermark

Product code	Description	Colour	Weight gsm	Size mm	Size inches	Pack qty
PAHMCP0290	Gelatine-sized CC2	Antique Light Toned	290	440 x 560	17 ⁵ / ₁₆ x 22 ¹ / ₁₆	1
PAHMCP0380	Gelatine-sized CC2	Antique Light Toned	380	440 x 560	17 ⁵ / ₁₆ x 22 ¹ / ₁₆	1
PAHMCP1380	Gelatine-sized CC2	Antique Light Toned	380	560 x 760	22 ¹ / ₁₆ x 29 ¹⁵ / ₁₆	1
PAHMCP0420	Gelatine-sized CC2	Antique Light Toned	420	560 x 760	22 ¹ / ₁₆ x 29 ¹⁵ / ₁₆	1
PAHMCU0290	Un-sized CC2	Antique Light Toned	290	440 x 560	17 ⁵ / ₁₆ x 22 ¹ / ₁₆	1
PAHMCU0380	Un-sized CC2	Antique Light Toned	380	440 x 560	17 ⁵ / ₁₆ x 22 ¹ / ₁₆	1
PAHMCU1380	Un-sized CC2	Antique Light Toned	380	560 x 760	22 ¹ / ₁₆ x 29 ¹⁵ / ₁₆	1
PAHMCU0420	Un-sized CC2	Antique Light Toned	420	560 x 760	22 ¹ / ₁₆ x 29 ¹⁵ / ₁₆	1

Moulin du Verger Decorative Cover Paper



A high-quality cover paper made using traditional methods with a variety of linen and hemp paper pulp – no two sheets are the same.

They can be used to make exceptional and unique cover paper bindings. Colour tones may vary from dark to light – please specify your preference.

Specifications

- Made from linen and manilla fibres

Applications

- Bookbinding
- Creative artwork



Decorative Cover Papers

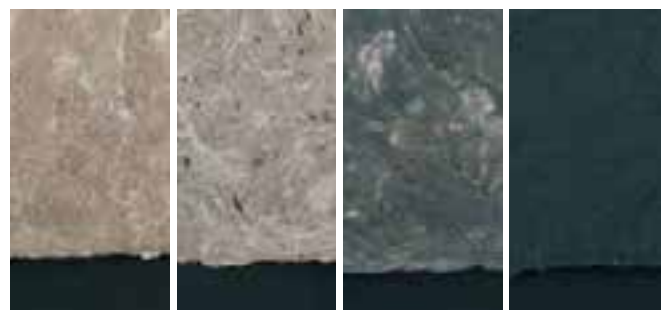

Product code	Description	Material	Weight gsm	Size mm	Size inches	Pack qty
PAHMCC0001	Moulin du Verger handmade decorative cover paper	Different tones	250	500 x 650	19 ¹ / ₁₆ x 25 ⁵ / ₁₆	1



Christopher Clarkson and Jacques Brejoux in discussion at the first workshop in 2007

Moulin du Verger – Iris Endpapers

This is a decorative paper made from the leaves of the iris plant which produces a beautiful translucent sheet. A very interesting paper for endpapers and other creative bookbinding applications.



Specifications

- Made from iris leaves

Applications

- Endpaper
- Creative bookbinding

Product code	Colour	Weight gsm	Size mm	Size inches	Pack qty
PAMVEP4456	Gentle tan	60	440 x 560	17 ⁵ / ₁₆ x 22 ¹ / ₁₆	1



Moulin du Verger from the rear showing the air drying loft



Griffen Mill Handmade Paper

The Griffen Handmade Paper Mill is based in Ireland and run by Christine Laver-Gibbs and Michael Gibbs. They produce Fine Art, Bookbinding and Conservation Papers from different blends of cotton, linen and hemp fibres refined on a Hollander beater. The paper is dried using a proprietary restraint method to aid stability and flatness. Since founding the mill they have developed an extensive range of colours and qualities for conservation and bookbinding applications and gained a wealth of knowledge, which they are eager to pass on through training courses.

Griffen Mill Bookbinding and Conservation Papers are made in a variety of weights and can be handled easily when damp. All papers are internally buffered and neutrally sized to give a pH reading of between 7.3 to 8.4. Weights range from 55gsm to 150gsm.



GM Handmade European Jute Tissue Paper



The tissues have a good wet-strength, are internally buffered and neutrally sized to give a pH reading of 7.3 to 8.4. The Mill produces a range of handmade archival Jute fibre tissues for conservation use. The tissue can be supplied in a variety of tones, weights and strengths. They are available as both wove and laid sheets. All Griffen Mill tissues are easy to handle when wet. The long fibres enable the tissue to hold its shape. The character is compatible with European papers since the tissues are made in exactly the same way as their heavier counterparts. Made in Royal/ Raisin size.

Product code	Colour	Weight gsm	Size mm	Size inches	Pack qty
PAGMT0001	Natural white	35	508 x 635	20 x 25	5

GM Ledger Paper, Gelatine-Sized.



Imperial size, white, internally buffered, gelatine-sized, laid paper with a smooth surface for use by Scribes and Calligraphers. The hard surface makes ink erasures possible. Similar properties to Whatman's Ledger paper of 70 years ago. Bookbinders may find it useful as a replacement semi-glazed endpaper for Victorian bindings.

Product code	Colour	Weight gsm	Size mm	Size inches	Pack qty
PAGMLE0001	Hard White	120	560 x 760	22 x 30	5

GM Handmade Wallpaper for Historic Reproduction

Off White, laid papers made from cotton with a good wet, burst and tensile strength. Internally sized and buffered. Available in two sizes Royal and Grand Elephant. Grand Elephant is so-called because of the provision of a trim margin for patterned papers.

Product code	Colour	Weight gsm	Royal size mm	Royal size inches	Pack qty
PAGMW0001	Off White - Laid	90	500 x 640	19 ¹ / ₁₆ x 25 ³ / ₆₄	5

Product code	Colour	Weight gsm	Grand elephant size mm	Grand elephant size inches	Pack qty
PAGMW0002	Off White - Laid	90	598 x 710	23 ³ / ₆₄ x 27 ⁶ / ₆₄	5



Creating a facsimile wallpaper using GM Handmade Wallpaper. Image Courtesy of Allyson McDermott Studio



GM Lining Paper for Historic Wallpaper Reproduction

Off White, laid papers made from cotton with a good wet, burst and tensile strength. Internally sized and buffered. Available in two sizes Royal and Grand Elephant.

Product code	Colour	Weight gsm	Royal size mm	Royal size inches	Pack qty
PAGMLI0001	Off White - Laid	90	500 x 640	19 ¹ / ₁₆ x 25 ³ / ₆₄	5

Product code	Colour	Weight gsm	Grand elephant size mm	Grand elephant size inches	Pack qty
PAGMLI0002	Off White - Laid	90	598 x 710	23 ³ / ₆₄ x 27 ⁶ / ₆₄	5

GM Character Laid and Wove

A range of Laid and Wove, Hollander beaten papers which are buffered and internally neutral-sized for conservation, bookbinding and print reproduction.

Product code	Product name	Colour	Weight gsm	Size mm	Size inches	Pack qty
PAGMLP0055	1730 Laid	Dull white	55	500 x 640	19 ¹ / ₁₆ x 25 ³ / ₆₄	5
PAGMLP0080	1730 Laid	Dull white	80	500 x 640	19 ¹ / ₁₆ x 25 ³ / ₆₄	5
PAGMLP0115	1730 Laid	Dull white	115	500 x 640	19 ¹ / ₁₆ x 25 ³ / ₆₄	5
PAGMBS0060	Broadsheet Laid	Dull white	60	500 x 640	19 ¹ / ₁₆ x 25 ³ / ₆₄	5
PAGMBS0115	Broadsheet Laid	Dull white	115	500 x 640	19 ¹ / ₁₆ x 25 ³ / ₆₄	5
PAGMOC0055	'Old Cleeve' Medieval Laid	Off White	55	532 x 646	20 ⁹ / ₁₆ x 25 ¹ / ₁₆	5
PAGMOC7803	'Old Cleeve' Medieval Laid	Off White	80	532 x 646	20 ⁹ / ₁₆ x 25 ¹ / ₁₆	5
PAGMOC0115	'Old Cleeve' Medieval Laid	Off White	115	532 x 646	20 ⁹ / ₁₆ x 25 ¹ / ₁₆	5
PAGMEW0080	'Early Wove' White	White	80	514 x 617	20 ⁹ / ₆₄ x 24 ¹ / ₆₄	5
PAGMEW0115	'Early Wove' White	White	115	514 x 617	20 ⁹ / ₆₄ x 24 ¹ / ₆₄	5
PAGMEC0080	'Early Wove' Cream	Cream	80	514 x 617	20 ⁹ / ₆₄ x 24 ¹ / ₆₄	5
PAGMEC0115	'Early Wove' Cream	Cream	115	514 x 617	20 ⁹ / ₆₄ x 24 ¹ / ₆₄	5



Hanging reproduction wallpaper. Image courtesy of Allyson McDermott Studio

Japanese Paper Collection

The conservation of graphic documents often requires the use of paper imported from the Far East. Conservators all over the world are aware of the qualities of Japanese paper (or Washi as the traditional paper is termed). For centuries it has been handmade for high-prestige varieties and high qualities. The best-known fibres are Kozo, Gampi and Mitsumata. Each of them gives the paper specific characteristics. Even the lightest weight of Japanese paper offers great physical strength and longevity thereby making it ideal for conservation work.

Kozo: the most widely used, its fibres are the longest (an average of 10mm and 3 times longer than cotton). They give paper great strength, flexibility and dimensional stability. Kozo accounts for 90% of the fibres used in Japanese paper with the best Kozo for traditional Japanese Washi paper coming from the cold mountainous regions of Japan. Other sources of Kozo are used by some Japanese machine-made papermakers where it is thought to have a particular quality.

Gampi: the characteristic feature is the sturdy, glossy fibres (fibre length between 3 and 5mm). Gampi produces paper which is strong, translucent and has a lustrous surface sheen. It can be very difficult - or even impossible - to grow, making Gampi a very precious fibre. It has one unusual feature; its sap is toxic and this means it is extremely resistant to damage caused by insects. Traditional uses include gold and silver leaf production.

Mitsumata: fine, absorbent, slightly glossy fibres (length between 3 and 5mm). Produces a very smooth paper, with more of a sheen than Kozo but less than Gampi. Used particularly in smooth or soft papers, suitable for calligraphy. Relatively less durable than other papers, Mitsumata fibres are sometimes combined with others.

Information

Wet-Tearing Japanese Papers

Because most Japanese papers are long-fibred, they are strongest when torn rather than cut. This also gives a feathered edge when used for lining artwork etc.

The best way to tear them is:

- 1. Fold the paper where you want it torn*
- 2. Draw a thin line of water along the fold with a brush*
- 3. With one hand, hold a metal straight edge on the fold line*
- 4. Lift the paper with the other hand, tearing the water-weakened line along the straight edge.*



Kozo fibre being washed in a Japanese papermaking village.

Japanese Paper Collection

Paper Nao Japanese Handmade Paper



Since our inception CXD have offered the Nao selection - from the paper source established by Naoki Sakamoto - to promote traditionally made Japanese papers of the highest quality. They have selected paper of consistent quality, free from impurities such as mechanical wood pulp or iron particles caused by poor materials and drying methods common to cheaper papers.

The pH value of the papers from Paper Nao range from 6.3 to 9.5.

The Paper Nao selection is available in handmade sheets and machine-made rolls produced on a stainless steel machine to avoid rust in the paper. These machine-made paper rolls are often preferred over handmade sheets for repairing or lining brittle machine-made papers which have a definable grain direction.

Typical characteristics of paper

KOZO FIBRE: Very long fibre. Durable with its own special sheen. Most frequently used type in Japan.

GAMPI FIBRE: Durable. Thin, almost transparent. Excellent wet-strength and lustrous surface. Traditional uses include gold and silver leaf productions.

MITSUMATA FIBRE: Used particularly in smooth or soft papers. Suitable for calligraphy. Relatively less durable than other papers, Mitsumata fibres are sometimes combined with others.

Fibre			
K = Kozo	M = Mitsumata	G = Gampi	
Cooking			
L = Lime Mortar (Ca OH ₂)	S = Sodium Carbonate (Na ₂ CO ₃)	C = Caustic Soda	W = Wood Ashes
Drying			
S = Stainless Steel		W = Wood Panel	

Applications

- Handmade Kozo Papers (K31 - 37) are all particularly suitable for conservation uses
- In addition to its conservation uses, Kozo paper (K37) is excellent for hinging
- Urushikoshi K93 is the thinnest handmade Japanese paper available in the Nao range
- Mitsumata Hakuai Shi (M5) is very soft and traditionally used for gold-leaf backing and in decorative boxmaking

 Linked Products: Brushes p216; Dahlia Spray p164; Shofu Paste p129 and Adhesives p127.

Sample swatch sets for the complete range are available to purchase.

The colour reproduction of papers and boards in this catalogue is a guide only. Sample swatches are available for colour-matching purposes from CXD.



PAJAPK0001
PAJAPK0025
PAJAPK0027
PAJAPK0028
PAJAPK0032
PAJAPK0036
PAJAPK0037
PAJAPK0038
PAJAPK0145
PAJAPK0148

Paper Nao Japanese Handmade Paper



Product code	Description	Fibre	Fibre	Cooking	Drying	pH	Loading/ buffer	Weight gsm	Size mm	Size inches	Pack qty
PAJAPG0024	G-24	Gampi-shi	G	S	W	6.3	-	14	440 x 550	17 ³ / ₁₆ x 21 ⁵ / ₈	10
PAJAPG0034	G-34	Gampi Kozo Kongoshi	G+K	S	W	6.4	-	21	440 x 550	17 ³ / ₁₆ x 21 ⁵ / ₈	10
PAJAPK0001	K-1	Kozo	K	L	W	6.8	-	46	320 x 430	11 ⁷ / ₁₆ x 16 ¹ / ₈	10
PAJAPK0025	K-25	Sekishu Hanshi	K	S	W	7.8	-	25	520 x 720	21 ¹ / ₄ x 29 ¹ / ₈	10
PAJAPK0027	K-27	Tengujo Kozo	K	L	S	6.7	-	15	540 x 780	21 ¹ / ₄ x 30 ¹ / ₁₆	10
PAJAPK0032	K-32	Minogami Chuniku Ishibaini	K	L	S	8.1	-	45-50	640 x 980	25 ³ / ₁₆ x 38 ³ / ₁₆	5
PAJAPK0036	K-36	Minogami Usukuchi	K	L	S	8.1	-	25	640 x 980	25 ³ / ₁₆ x 38 ³ / ₁₆	10
PAJAPK0037	K-37	Minogami Usukuchi	K	L	S	8.1	-	19	640 x 980	25 ³ / ₁₆ x 38 ³ / ₁₆	10
PAJAPK0038	K-38	Usu Mino	K	L	S	8.1	-	16	640 x 980	25 ³ / ₁₆ x 38 ³ / ₁₆	10
PAJAPK0145	K-145	Kozo	K	S	S	8.2	-	16	640 x 980	25 ³ / ₁₆ x 38 ³ / ₁₆	10
PAJAPK0148	K-148	Kozo	K	S	S	8.2	-	40	640 x 980	25 ³ / ₁₆ x 38 ³ / ₁₆	5
PAJAPK0057	K-57	Tosa Seicho Shi	K	L	W	7.2	-	49	730 x 1020	28 ³ / ₄ x 40 ³ / ₁₆	5
PAJAPK0060	K-60	Tosa Seicho Shi	K	L	W	7.2	-	36	730 x 1020	28 ³ / ₄ x 40 ³ / ₁₆	5
PAJAPK0062	K-62	Kozo	K	L	S	8.5	calcium	30	320 x 1490	12 ³ / ₈ x 58 ¹ / ₁₆	10
PAJAPK0063	K-63	Kozo	K	L	S	8.5	calcium	40	320 x 1490	12 ³ / ₈ x 58 ¹ / ₁₆	10
PAJAPK0064	K-64	Sugihara Nagaban	K	S	S	8.8	-	25	360 x 1360	14 ³ / ₁₆ x 53 ³ / ₁₆	10
PAJAPK0093	K-93	Kozo	K	S	W	8.7	clay	5.7	240 x 490	9 ¹ / ₁₆ x 19 ³ / ₁₆	10
PAJAPK0101	K-101	Tosa kozo Shi Kasaban	K	S	W	9.4	-	46	400 x 490	15 ³ / ₄ x 19 ³ / ₁₆	10
PAJAPK0141	K-141	Kozo	K	S	W	9.6	clay	15	260 x 650	10 ¹ / ₄ x 25 ³ / ₁₆	10
PAJAPK0143	K-143	Kozo	K	S	W	9.6	clay	32	260 x 650	10 ¹ / ₄ x 25 ³ / ₁₆	10
PAJAPM0005	M-5	Mitsumata Hakuai Shi	M	L	W	6.6	-	11	560 x 700	22 ¹ / ₁₆ x 27 ³ / ₁₆	10
PAJAPM0006	M-6	Mitsumata Hakuai Shi	M	S	W	6.8	-	20	560 x 700	22 ¹ / ₁₆ x 27 ³ / ₁₆	10
PAJAPM0016	M-16	Mitsumata Hakuai Shi	M	L	W	7.3	-	35	750 x 1020	29 ¹ / ₂ x 40 ³ / ₁₆	5
PHPNB7048	Set of 3 Books	Various Paper Nao Samples	-	-	-	-	-	-	-	-	1

Paper Nao Japanese Machine-Made Paper - Rolls

These machine-made rolls are made on a stainless steel machine to prevent rust contamination. The paper on rolls has a definable grain direction and it is sometimes preferable to handmade paper for use in repairing or lining damaged or brittle machine-made papers as grain direction can be aligned. All the papers on rolls are made using the same Kozo fibres as used in the handmade papers.



Linked Products: Japanese Materials p95; Japanese Brushes p216-220; Dahlia Spray p164.

Product code	Description	Fibre	Fibre	Cooking	Drying	pH	Loading/ buffer	Weight gsm	Size mm	Size inches	Pack qty
PAJARK0000	RK-00 - Roll	Kozo	K	L	S	7.3	-	3.6	1mm x 61m	1/32 x 2401 ¹ / ₁₆	1
PAJARK1000	RK-0 - Roll	Kozo	K	L	S	7.3	-	5	1mm x 61m	1/32 x 2401 ¹ / ₁₆	1
PAJARK0001	RK-1 - Roll	Kozo	K	L	S	7.3	-	8	1mm x 61m	1/32 x 2401 ¹ / ₁₆	1
PAJARK0002	RK-2 - Roll	Kozo	K	L	S	7.3	-	11	1mm x 61m	1/32 x 2401 ¹ / ₁₆	1
PAJARK0004	RK-4 - Roll	Kozo	K	C	S	7	calcium	38	1mm x 61m	1/32 x 2401 ¹ / ₁₆	1
PAJARK0009	RK-9 - Roll	Kozo	K	C	S	8.9	calcium	31	1mm x 61m	1/32 x 2401 ¹ / ₁₆	1
PAJARK0012	RK-12 - Rol	Kozo	K	C	S	8.2	-	20	1mm x 61m	1/32 x 2401 ¹ / ₁₆	1
PAJARK0015	RK-15 - Roll	Kozo	K	C	C	7.2	-	10	1mm x 61m	1/32 x 2401 ¹ / ₁₆	1
PAJARK0017	RK-17 - Roll	Kozo	K	C	S	7.2	-	19	1mm x 61m	1/32 x 2401 ¹ / ₁₆	1
PAJARK0019	RK-19 - Roll	Kozo	K	C	S	7.2	-	32	1mm x 61m	1/32 x 2401 ¹ / ₁₆	1
PAJARK0020	RK-20 - Roll	Kozo	K	C	S	7.2	-	40	1mm x 61m	1/32 x 2401 ¹ / ₁₆	1
PAJARK0027	RK-27 - Roll	Kozo	K	L	S	7.3	-	18	1mm x 61m	1/32 x 2401 ¹ / ₁₆	1
PAJARK0028	RK-28 - Roll	Kozo	K	L	S	7.3	-	39	1mm x 61m	1/32 x 2401 ¹ / ₁₆	1
PAJARK0029	RK-29 - Roll	Kozo	K	L	S	7.3	sizing	34	1mm x 61m	1/32 x 2401 ¹ / ₁₆	1

pH values obtained using Japanese Industrial Standards (JIS) P-8133 cold water or extraction method.



Japanese Paper – S13 Selection

The S13 Japanese Paper Selection responds to a multitude of quality and economy requirements and covers a wide spectrum of uses.

HM: handmade **MM:** machine-made

The S13 Japanese Paper selector is available to purchase but is refundable following an order.

Sheeted Machine-Made Paper. Mixed Fibres

Product code	Description	Process	Size mm	Size inches	Weight gsm	pH	Pack qty
PAJAPJ0130	Easy Tear Hinging Strip Paper: 100% Thai Kozo*	MM	600 x 430	23 ⁵ / ₈ x 16 ⁵ / ₈	20	7	5
PAJAPJ5252	Mitsumata 5: 100% Japanese Mitsumata	MM	560 x 700	22 ¹ / ₄ x 27 ¹ / ₈	11	6.6	5
PAJAPJ6101	Gampi: 100% Japanese Gampi	MM	455 x 610	17 ⁵ / ₈ x 24 ¹ / ₄	12	7.3	5
PAJAPJ3510	Ino Shi: 30% Japanese Kozo 70% Manilla Hemp	MM	485 x 700	19 ¹ / ₂ x 27 ¹ / ₈	18	6.5	5
PAJAPJ2180	Tosa Washi: 10% Thai Kozo 20% Rayon 70% Pulp	MM	630 x 940	24 ⁵ / ₈ x 37 ³ / ₈	28	6.5	5
PAJAPJ4870	Shoji: 100% Purified Pulp	MM	620 x 920	24 ³ / ₂ x 36 ³ / ₂	48	6.2	5

*Linked to Easy Tear in the tapes section - Page 132

Sheeted Machine-Made Paper. 100% Manilla Hemp Fibres

Product code	Description	Process	Size mm	Size inches	Weight gsm	pH	Pack qty
PAJAPJ5561	'Tengujo': 100% Manilla Hemp	MM	480 x 940	18 ⁷ / ₈ x 37 ¹ / ₄	6	6.7	5
PAJAPJ9140	Long fibre tissue paper: 100% Manilla Hemp	MM	490 x 760	19 ¹ / ₄ x 29 ⁵ / ₈	9	6.8	5
PAJAPJ5502	'Tengujo' Kashmir: 100% Manilla Hemp	MM	480 x 940	18 ⁷ / ₈ x 37 ¹ / ₄	9	6.7	5
PAJAPJ4050	Kuranai Nature: 100% Manilla Hemp	MM	520 x 740	20 ⁵ / ₈ x 29 ¹ / ₄	9	7.3	5
PAJAPJ4061	Maruishi: 100% Manilla Hemp	MM	610 x 910	24 ¹ / ₄ x 35 ³ / ₈	9	7.1	5
PAJAPJ5160	Gifu: 100% Manilla Hemp	MM	610 x 910	24 ¹ / ₄ x 35 ³ / ₈	10	7.2	5
PAJAPJ5500	Kashmir: 100% Manilla Hemp	MM	480 x 940	18 ⁷ / ₈ x 37 ¹ / ₄	11	6.8	5
PAJAPJ7240	Bib Tengujo: 100% Manilla Hemp	MM	480 x 750	18 ⁷ / ₈ x 29 ¹ / ₂	12	7.1	5
PAJAPJ5508	'Tengujo': 100% Manilla Hemp	MM	490 x 690	19 ¹ / ₄ x 27 ¹ / ₄	17	6.7	5
PAJAPJ0331	100% Manilla Hemp	MM	635 x 940	25 x 37 ¹ / ₄	30	7.5	5
PAJAPJ0332	100% Manilla Hemp	MM	635 x 940	25 x 37 ¹ / ₄	60	7.5	5

 [Link to 9.3 gsm Spider's Wet-strength Tarantula Tissue p99, 100% Manilla Hemp with High Wet-strength p98.](#)

Handmade Sheets, Mixed Fibres

Product code	Description	Process	Size mm	Size inches	Weight gsm	pH	Pack qty
PAJAPJ3040	Tengujo M6: 100% Thai Kozo	HM	540 x 800	21 ¹ / ₄ x 31 ¹ / ₂	9	6.7	5
PAJAPJ2161	Kinugawa Ivory: 80% Thai Kozo 20% Purified Pulp	HM	620 x 910	24 ³ / ₂ x 35 ³ / ₈	22	7	5
PAJAPJ2172	Kozo Shi: 40% Thai Kozo 60% Purified Pulp	HM	620 x 970	24 ³ / ₂ x 38 ³ / ₈	23	6.2	5
PAJAPJ2221	Kawanaka Ivory: 75% Thai Kozo 25% Purified Pulp	HM	600 x 910	23 ⁵ / ₈ x 35 ³ / ₈	29	6.8	5
PAJAPJ2381	Arakaji Nature: 40% Thai Kozo 60% Purified Pulp	HM	610 x 980	24 ¹ / ₄ x 38 ³ / ₈	31	6.2	5
PAJAPJ2461	Kozo Nature: 50% Thai Kozo 50% Pulp	HM	640 x 980	25 ¹ / ₄ x 38 ³ / ₈	34	6.6	5
PAJAPJ4500	Hosokawa Ivory: 80% Thai Kozo 20% Pulp	HM	610 x 910	24 ¹ / ₄ x 35 ³ / ₈	39	7.5	5
PAJAPJ4670	Shiohara White: 50% Thai Kozo 50% Pulp	HM	620 x 920	24 ³ / ₂ x 36 ³ / ₂	40	7.1	5
PAJAPJ5831	Udagami: 70% Japanese Kozo 30% Pulp	HM	600 x 960	23 ⁵ / ₈ x 37 ³ / ₈	50	6.9	5
PAJAPJ1171	Atsu-Shi: 40% Thai Kozo 60% Pulp	HM	640 x 970	25 ¹ / ₄ x 38 ³ / ₈	67	6.6	5
PAJAPJ2181	Bunkoshi: 20% Thai Kozo 20% Rayon 60% Pulp	HM	640 x 880	25 ³ / ₈ x 34 ¹ / ₄	71	6.2	5



Handmade Sheets, Japanese Fibre

Product code	Description	Process	Size mm	Size inches	Weight gsm	pH	Pack qty
PAJAPJ2141	Kozo K 35: 100% Japanese Kozo	HM	620 x 980	24 ³ / ₂ x 38 ³ / ₈	18	8	5
PAJAPJ2191	Usumino B6: 100% Japanese Kozo	HM	620 x 920	24 ³ / ₂ x 36 ³ / ₂	28	7.1	5
PAJAPJ2230	Kozo 43: 100% Japanese Kozo	HM	560 x 930	22 ¹ / ₄ x 36 ³ / ₈	29	7.7	5
PAJAPJ2281	Shibori: 100% Japanese Kozo	HM	680 x 1030	26 ³ / ₈ x 40 ⁵ / ₈	29	7.4	5
PAJAPJ4661	Kozo K 33: 100% Japanese Kozo	HM	620 x 980	24 ³ / ₂ x 38 ³ / ₈	40	8	5
PAJAPJ5781	Takogami: 100% Japanese Kozo	HM	675 x 980	26 ³ / ₈ x 38 ³ / ₈	43	6.7	5

Machine-Made Paper on Rolls. Mixed Fibres

Product code	Description	Process	Size mm	Size inches	Weight gsm	pH	Pack qty
PAJAPR3070	Kizuki-Kozo White: 100% Thai Kozo	MM	910 x 50m	35 ⁵ / ₈ x 164ft ¹ / ₂	6	7	1
PAJAPR3270	Kizuki-Kozo Cream: 100% Thai Kozo	MM	910 x 50m	35 ⁵ / ₈ x 164ft ¹ / ₂	6	7	1
PAJAPR3271	Kizuki-Kozo Cream: 100% Thai Kozo	MM	900 x 500m	35 ¹ / ₁₆ x 19685 ⁵ / ₈	6	7	1
PAJAPR3074	Kizuki-Kozo Brown: 100% Thai Kozo	MM	910 x 50m	35 ⁵ / ₈ x 164ft ¹ / ₂	6	7	1
PAJAPR3470	Kizuki-Kozo White: 80% Thai Kozo 20% Pulp	MM	910 x 50m	35 ⁵ / ₈ x 164ft ¹ / ₂	17	7	1
PAJAPR2380	Sekishu Shi: 50% Thai Kozo 50% Pulp	MM	960 x 60m	37 ⁵ / ₈ x 196ft 10 ³ / ₈	31	7.2	1
PAJAPR4050	Kuranai Nature: 100% Manilla Hemp (No Wet-strength)	MM	1000 x 100m	39 ⁵ / ₈ x 393ft ⁵ / ₈	9	7.3	1

Machine-Made Paper on Rolls. Japanese Fibres

Product code	Description	Process	Size mm	Size inches	Weight gsm	pH	Pack qty
PAJAPR9391	Mitsumata 79: 100% Japanese Mitsumata	MM	915 x 305m	36 ¹ / ₂ x 1200 ³ / ₂	12	8	1
PAJAPR0003	Kozo Shi Cream: 100% Japanese Kozo	MM	1000 x 61m	39 ⁵ / ₈ x 240 ³ / ₂	3	7	1
PAJAPR0004	Kozo Shi Cream: 100% Japanese Kozo	MM	1000 x 61m	39 ⁵ / ₈ x 240 ³ / ₂	3.7	7	1
PAJAPR0364	Kozo Nature: 100% Japanese Kozo	MM	1000 x 60m	39 ⁵ / ₈ x 236 ³ / ₂	4	7.8	1
PAJAPR5781	Takogami Cream: 100% Japanese Kozo	MM	980 x 60m	38 ³ / ₈ x 236 ³ / ₂	45	6.7	1
PAJAPR5500	Takogami White: 100% Japanese Kozo	MM	1120 x 60m	44 ³ / ₂ x 236 ³ / ₂	65	6.7	1
PAJAPR5501	Takogami White: 100% Japanese Kozo	MM	1120 x 10m	44 ³ / ₂ x 39 ⁵ / ₈	65	6.7	1
PAJAPR5502	Takogami Cream: 100% Japanese Kozo	MM	980 x 60m	38 ³ / ₈ x 236 ³ / ₂	65	6.7	1

CXD Special Selection Japanese Paper Collection

The following exclusive papers have been selected and commissioned by ourselves because of their high-quality and special characteristics.

Tosa Kozo by Fujiwara Masuhiko

Tosa being the ancient name of the Kochi Prefecture in Japan.

Traditional Washi Paper made by Fujiwara Masuhiko in the Tosa area of Japan from the finest quality local Kozo. Tosa Kozo is thought to be the strongest of Japanese Kozo fibres.

In the words of Hiromi Tanimura who introduced us to this paper, "Making a consistent lightweight paper is especially hard in large sizes. It is unusual to find this quality in such a large handmade sheet. Fujiwara-san is renowned for achieving a consistent thickness and gsm weight".



All the papers are made at 630 x 980mm except for No.2 which has the option of a half-size sheet.

Standard stock gsm weights are: 12.2, 18.3, 30.6, 49.0 with 97.8 to special order subject to minimum quantity requirement.

In Japan the traditional unit of measure for a paper's weight is called a Momme which equals 3.75gsm.

Other weights or variations can be commissioned using a mixture of 90% Tosa Kozo and 10% or 20% Nasu Kozo to make the paper harder.

Our standard stock is unbuffered with a pH6.5 to 7.5. Paper-buffered with Gofun (traditional Japanese shell powder/calcium carbonate) can also be supplied to special order where the pH will be 8.5 to 9. Special orders should be placed before the winter season when the paper is made.

All Fujiwara Tosa papers are cooked with caustic soda ash for a smooth finish and sun-dried on wooden boards.

Product code	Description	Fibre	Weight gsm	Size mm	Size inches	Pack qty
PATOSA0002	No. 2 Tosa Kozo Unbuffered 100%		12.2	630 x 980	24 ³ / ₄ x 38 ³ / ₄	10
PATOSA0003	No. 3 Tosa Kozo Unbuffered 100%		18.3	630 x 980	24 ³ / ₄ x 38 ³ / ₄	10
PATOSA0005	No. 5 Tosa Kozo Unbuffered 100%		30.6	630 x 980	24 ³ / ₄ x 38 ³ / ₄	10
PATOSA0008	No. 8 Tosa Kozo Unbuffered 100%		49.0	630 x 980	24 ³ / ₄ x 38 ³ / ₄	10
PATOSA0012*	No. 12 Tosa Kozo Unbuffered 100%		73.4	630 x 980	24 ³ / ₄ x 38 ³ / ₄	10
PATOSA0016*	No. 16 Tosa Kozo Unbuffered 100%		97.8	630 x 980	24 ³ / ₄ x 38 ³ / ₄	10

*to special order



Wet paper is brushed onto wooden boards to dry

TENGU 2gsm Natural Shade Kozo Tissue

Tosa 'Tengu' Washi commonly known as Tosa Tengujo-shi in Japanese is likened to the "wings of a mayfly". Made from high-quality Japanese Tosa Kozo, this tissue is the thinnest machine-made Kozo tissue available today. All Tengu tissue papers are made on a special stainless steel tissue paper machine.



The 'natural shade' Tengu Kozo is cooked with lime mortar and the Kozo bark and other impurities that remain in unbleached fibre is removed completely by hand. The colour and character of the unbleached paper is particularly appropriate for old documents of a darker tone. It is also possible to supply the tissue made with chlorine-free, bleached pulp and in a variety of dyed shades to suit even darker-toned papers or other materials where a strong but thin Kozo tissue would be appropriate to aid its preservation.

Product code	Material	Size mm	Size inches	Cooking	Drying	pH value	Roll
PATGKZ0001	Japanese Kozo	970mm x 61m	38 ³ / ₁₆ x 2401 ³ / ₄	Lime Mortar (Ca(OH) ₂)	Stainless Steel	7.2	1

Our current stock weight is 2.0gsm but other weights are available up to 34gsm.

Whisper Tissue™, Re-Moistenable Starch-Coated Japanese Kozo Tissue

Exclusive to Conservation By Design, Whisper Tissue™ is a new concept in lining documents with Japanese tissue.

This 100% Tosa Kozo, 4gsm tissue has been coated with a re-moistenable, non-ionic, neutral pH (6-8) tapioca starch adhesive.

After application the 4gsm tissue is virtually invisible. Tosa Kozo is reputed to be the strongest amongst Japanese Kozo fibres and makes it ideal for this super-thin paper.

It can be applied directly to wet paper after washing and simply brushed down and left to dry on the paper. It can also be placed over dry paper and moistened with a fine water mist, applied with a Dahlia spray or similar piece of equipment, before smoothing with a brush or pressing under release paper. It is ideal for lining documents and artwork, book conservation and repairing tears of lightweight paper. If used on heavier paper more than one layer may need to be applied.



Applications

Lining, Repair and Hinging



Adhesive side tested

Specifications

Support Tissue: 4gsm, 100% Japanese Tosa Kozo, machine-made Washi

Adhesive: Tapioca starch, non-ionic, pH6 to 8

Roll size: W 1 metre x L 10 metres

Also available in narrow-width hinging and repair tapes. See tapes section



Product code	Description	Size mm	Fibre	Gsm	Adhesive coating
PAJAPL7910	Re-moistenable Starch Adhesive-Coated 4gsm Tissue	1000 x 10m	Tosa Kozo	4	Tapioca Starch

Tissue and Lightweight Papers

Spider's Wet-Strength Tarantula Tissue

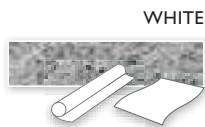

WHITE

Made exclusively for CXD, this is a high wet-strength, unbuffered, low-opacity, long-fibre tissue made of 100% Manilla fibre. Developed for coating, lining and repair work in painting and paper conservation. As it is soft and strong it is used for padding costumes, wrapping, interleaving and making nests for delicate museum objects. The high wet-strength makes it ideal for use in conservation wet treatments. It can be used with starch or other aqueous adhesives.

An economical alternative to the more expensive Japanese Kozo tissue paper, it is also available ready-coated with Paraloid/Texicryl heat-activated adhesive for transparent lamination, linings and repairs.

Specifications

- pH7
- 100% Manilla fibre
- Excellent wet-strength (Polyamide – Polyamine epichlorohydrin resin)
- Unbuffered
- Max. amount of wet-strength = 1% of dry fibre
- Hemcellulose less than 5%
- Tensile strength > 3.00N/15mm
- Whiteness 75%



Applications

- Lining
- Wrapping
- Interleaving
- Heat-set lamination

Linked Products: Archibond Tissue SUARCH0010/SUARCH0100 p105; Unsupported Archibond Adhesives p105.

Product code	Roll/sheet	Weight gsm	Size mm	Size inches	Pack qty
PASWTT0100	Roll	9.3	970 x 100m	38 ³ / ₁₆ x 328ft	1
PASWTT1000	Roll	9.3	970 x 1000m	38 ³ / ₁₆ x 3280ft	1
PASWTT7651	Sheet	9.3	760 x 510	29 ¹⁵ / ₁₆ x 20 ¹ / ₁₆	500

CXD Acid-Free Tissue - Unbuffered



WHITE

A translucent, general purpose, short-fibred, acid-free tissue paper for wrapping, interleaving and storage. Suitable for wrapping silver, textiles and other objects in Museum, Library and Archive collections.

Specifications

- pH6 to 7
- 100% Chemically Bleached Pulp
- Unbuffered
- Moisture 6.1 to 6.8%



Applications

- Lining
- Wrapping
- Interleaving
- Lamination

Product code	Weight gsm	Size mm	Size inches	Pack qty
PAAFTP0500	17	500 x 750	19 ¹¹ / ₁₆ x 29 ¹ / ₂	500
PAAFTP1000	17	1000 x 750	39 ³ / ₈ x 29 ¹ / ₂	500

OK Tissue

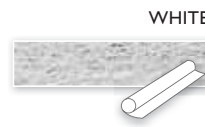

WHITE

High wet-strength, long-fibred tissue paper. Made from acid and lignin-free, purified wood pulp containing a high percentage of alpha cellulose. It is OBA-free and contains no chemical or alkaline buffers to raise the pH.

OK Tissue is a good low-cost alternative to Japanese Kozo paper for lining large artwork, maps and posters. Two weights available.

Specifications

- pH6 to 8
- Made from purified wood pulp
- Unbuffered
- High wet-strength
- OBA-free



Applications

- Lining
- Wrapping
- Interleaving
- Lamination

Product code	Colour	Weight gsm	Size mm x m	Size inches	Pack qty
PABOLLO001	White	12	750 x 30	29 ¹ / ₂ x 98.4ft	Roll
PABOLLO002	White	12	750 x 1500	29 ¹ / ₂ x 4921ft	Roll
PABOLLO003	White	22	750 x 30	29 ¹ / ₂ x 98.4ft	Roll
PABOLLO004	White	22	1540 x 30	60 ³ / ₈ x 98.4ft	Roll
PABOLLO005	White	22	750 x 1000	29 ¹ / ₂ x 3280ft	Roll
PABOLLO006	White	22	1540 x 1000	60 ³ / ₈ x 3280ft	Roll

Crystal Glassine Paper



A semi-transparent, acid-free (pH7 to 7.3) version of the traditional Glassine paper long-popular for making envelopes, folders and use in photograph and wedding albums. Available in Plain wove or with an embossed pattern. Patterns include: Linen, Cobweb and Arabesque.

Applications

- Applications: Envelope, folders and interleaving

Available in sheets and rolls

Product code	Surface	Weight gsm	Size mm	Size inches	Pack qty
PAGLAR1040	Plain wove	40	1000 x 500m	39 ³ / ₈ x 1968ft	Roll
PAGLAS6030	Cobweb	30	750 x 1000	29 ⁷ / ₂ x 39 ³ / ₈	50
PAGLAS1030	Cobweb	30	500 x 700	19 ¹ / ₁₆ x 27 ³ / ₈	50
PAGLAS4030	Linen	30	750 x 1000	29 ⁷ / ₂ x 39 ³ / ₈	50
PAGLAS2030	Linen	30	500 x 700	19 ¹ / ₁₆ x 27 ³ / ₈	50
PAGLAS5030	Arabesque	30	750 x 1000	29 ⁷ / ₂ x 39 ³ / ₈	50
PAGLAS3030	Arabesque	30	500 x 700	19 ¹ / ₁₆ x 27 ³ / ₈	50
PAGLAS2040	Plain wove	30	750 x 1000	29 ⁷ / ₂ x 39 ³ / ₈	50
PAGLAS1040	Plain wove	30	500 x 700	19 ¹ / ₁₆ x 27 ³ / ₈	50

Blotting Paper

CXD Heritage Acid-Free Blotting Paper



This general purpose blotting paper is made exclusively for Conservation By Design using chemically purified "wood-free" fibre. It is acid and lignin-free, buffered with calcium carbonate and has a pH of 8.5. The paper has a matt surface and good absorbency.

Specifications

- pH of 8.5
- Acid-free
- Lignin-Free



Applications

- Conservation treatments
- Disaster recovery

Linked Products: Drying Rack p172; Vacuum Packing Machine p105, 106 and 166-168; Disaster Recovery Equipment p187.

Product code	Colour	Weight gsm	Size mm	Size inches	Pack qty
PAAFBPO343	White	140	343 x 432	13½ x 17¼	250
PAAFBPO686	White	140	864 x 686	34¼ x 27¼	250
PAAFBPO500	White	220	500 x 650	19½ x 25½	125
PAAFBPO800	White	220	800 x 25m	31½ x 98¾	Roll
PAAFBPO600	White	300	600 x 800	23¾ x 31½	100
PAAFBP1100	White	300	800 x 1100	31½ x 43¼	50
PAAFBP1200	White	300	800 x 1200	31½ x 47¼	50

CXD Multisorb™ 100% Cotton Highly Absorbent, Wet-strength Blotter



A high wet-strength, specialist blotter which outperforms other blotters of similar weight. It is acid-free and made from 100% cotton.

Specifications

- Acid-free
- 100% cotton
- Wet-strength



Applications

- Conservation treatments
- Disaster recovery

Linked Products: See pHoton™ Section p63, 88; Vacuum Packing Machine p105, 106 and 166-168; Disaster Recovery Equipment p187.

Product code	Colour	Weight gsm	Size mm	Size inches	Pack qty
PAHWSB0003	White	280	750 x 1360	29½ x 53¼	50
PAHWSB0004	White	280	750 x 680	29½ x 26¾	50



Storage and drying books vacuum-packed with blotter/newspaper, awaiting treatment at a conservation studio in Prague



Identical test volumes – Prague
The book on the left was dried using the Squelch Drying technique, which gave better results than the freeze-dried test shown on right

Megasorb™ 100% Cotton Extra-Heavy Blotter



A 100% cotton, high-purity, extra-heavy blotting paper. Megasorb™ is acid-free and thick enough to use as a mattress making it ideal for use where high-capacity absorbency is needed. It has a smooth, matt surface finish.

Specifications

- Acid-free
- 100% cotton
- OBA-free



Applications

- Conservation treatments
- Disaster recovery

Linked Products: Drying Rack p172; Vacuum Packing Machine p105, 106 and 166-168; Disaster Recovery Equipment p187.

Product code	Colour	Weight gsm	Size mm	Size inches	Pack qty
PAXHBP0001	White	500	510 x 670	20¼ x 26¾	50
PAXHBP0002	White	500	670 x 1020	26¾ x 40¾	50

pHoton™ Aqua-Forte - High Wet-Strength



A lightweight and high wet-strength blotter that will not disintegrate when wet. The unusual roll format has proved useful for working on vacuum tables. Matt finish.

Specifications

- pH6 to 7
- Acid-free
- Cellulose from purified pulp
- Wet-strength
- Klemm 80m



Applications

- Conservation treatment and repair work
- Suitable for working with large posters, textiles etc
- Disaster Preparedness/Emergency Response
- Ideal for use on conservation suction tables

Linked Products: Vacuum Tables p168; Disaster Recovery Equipment p187.

Product code	Colour	Weight gsm	Size mm	Size inches	Pack qty
PHAQUA0090	White	90	1000mm x 100m	39¾ x 328ft	Roll



ArchiPress™ vacuum-packing machine in use for Squelch Drying flood-damaged materials



Wet books soon go mouldy if not frozen or vacuum-packed

pHoton™ Bench Blot

pHoton™ Bench Blot is smooth-finished, polyethylene-coated, absorbent paper which is unbuffered and acid-free, designed for the protection of laboratory benches and working areas. Spills of chemicals, toxic and infectious materials etc. are quickly soaked up in the filter paper and the layer of polyethylene prevents penetration to the surface below. Contaminated Bench Blot can be disposed of safely by burning, since the polyethylene coating is of virgin material containing no Butylated Hydroxy Toluene.



Specification Paper

- pH6 to 7
- Acid-free
- Polyethylene-coated
- Unbuffered
- Cellulose from purified pulp
- Wet-strength
- Klemm 80m



Specification Plastics

- pH6 to 7
- Virgin polyethylene, heat-bonded to paper
- Free of plasticisers
- Free of residual solvents
- Free of active sulphur compounds
- Free of BHT
- For full pHoton™ range of 'high-purity' papers see p89

Applications

- For conservation treatments
- Bench liner
- Disaster recovery
- Boxmaking

Linked Products: pHoton™ Range p63, 88; Disaster Recovery Equipment p187.

Product code	Colour	Weight gsm	Size mm x m	Size inches	Pack qty
PHBENC4003	White	165	500 x 50m	19 ¹¹ / ₁₆ x 164ft	1

The Prague flood of 2002



Papermaking and Leafcasting Fibres

Cellulose Powder

100% cotton-powdered fibre for infilling, repair and policing of damaged and worm-eaten papers.



Product code	Ref	Weight gsm	Pack qty
SUCPCC0041	CC41 Micro Crystalline	500	1
SUCPCF0001	CF1 Long Fibrous	500	1
SUCPCF0011	CF11 Short Fibrous	500	1

Information

Leafcasting

In the late 1950s, Esther Alkalay and Yulia Petrovna Nyuksha began experimenting with the concept of filling missing areas in paper with fibres suspended in a liquid medium. By 1961, equipment for this purpose had been developed and was in use in laboratories located in Eastern Europe and the U.S.S.R. The process has come to be known as 'leafcasting', and is best described in the preprints of the 1980 Cambridge Conference (see bibliography). For the latest in leafcasting technology see CXD Equipment, Multirestor Machine p166.

For more information on Squelch Drying please visit our website.

Linked Products: pHoton™ Range p63, 88; Disaster Recovery Equipment p187.

Cotton Linters Machine-Made



Cotton Linters are the basis of most modern cotton papers. This fibre is taken directly from the cotton plant and not from old cotton rags. They are usually made from the second-cut, short fibres left after the longer fibres have been taken for the textile industry. The fibres are processed into rough sheets ready to be cut into small pieces, dissolved in water and beaten to the required degree for the type of paper required when casting repairs. Fibres can be mixed with a water-soluble adhesive such as Tylose if required. Beaters vary according to the scale of production and can range from industrial hydro pulpers to home kitchen blenders. Conservation By Design are able to offer a small laboratory blender.

Specification Paper

- 100% cotton fibre

Applications

- Leafcasting
- Pulp repair

Linked Products: Vacuum Tables p168, Pulpers p166.

Product code	Weight gsm	Size mm	Size inches	Pack qty
PACOTT1000	1000	690 x 810	27 ¹¹ / ₆₄ x 31 ⁵ / ₆₄	10

Flax Pulp – Machine-Made



Machine-made flax pulp board. Flax is recognised as being the best pulp for manufacturing many types of European-style paper which are designed to be kept for a long time. The use of flax pulp is something of a secret within the paper industry and the kind we offer is an alternative to cotton pulp or can be mixed with cotton.

Linked Products: Vacuum Tables p168, Pulpers p166.

Product code	Size mm	Size inches	Weight gsm	Pack qty
PACLIN0580	640 x 790	25 ¹³ / ₆₄ x 31 ⁷ / ₆₄	580	10

Also available Moulin du Verger Handmade Pulp Sheets

Silicone Release, Synthetic Non-Woven and Heat-Set Material

Silicone Vegetable Parchment Release Paper

TRANSLUCENT WHITE



A 42gsm, two-sided, solvent-free, silicone-treated vegetable parchment. Has a degree of porosity often favoured by conservators and bookbinders.

Specifications

- Elemental chlorine-free
- Chemically purified fibre
- Unbuffered
- Available on rolls to special order

Linked Products: Tacking Iron p162-163; Hot Press p171.

Product code	Colour	Weight gsm	Size mm	Size inches	Pack qty
PASTVP0042	Translucent White	42	760 x 510	29 ¹⁵ / ₁₆ x 20 ¹ / ₁₆	25

Silicone Release Paper – two-sided

An acid-free kraft paper which has been silicone-coated on 2 sides. A medium-weight release paper for wet or dry-mounting.



Product code	Weight gsm	Size mm	Size inches	Pack qty
PASILIO001	92	1270 x 25m	50 x 984 ¹ / ₄	Roll

Linked Products: Tacking Iron p162-163; Hot Press p171.

Teflon® PEFE Cloth

Glass-fibre cloth impregnated with Teflon® (Polytetrafluoroethylene) has the following outstanding properties: anti-stick, excellent chemical and mechanical resistance can be used up to 260°C and is easy to clean. The 500gsm version is heavy-duty release layer designed for use over an extended period primarily in connection with a hard-bed hot plate laminator, power press or semi-matic heat laminator. Both sides are suitable for release work and give excellent long-term use.



Applications: suitable for heat-activated lamination without risk of adherence.

Product code	Weight gsm	Size mm	Size inches	Pack qty
SUTEFC0001	136	210 x 297	8 ¹ / ₄ x 11 ³ / ₄	5
SUTEFC0002	136	1000 x 3000	39 ³ / ₈ x 118 ¹ / ₄	Roll
SUPTFE7050	500	1000 x 1000	39 ³ / ₈ x 39 ³ / ₈	1
SUPTFE7051	500	500 x 1000	19 ¹ / ₁₆ x 39 ³ / ₈	1

Linked Products: Tacking Iron p162-163; Hot Press p171, semi-matic laminator p170.

Stouls Non-Woven Polyester

Smooth, opaque, 100% non-woven polyester. Chemically inert and resistant in a natural white colour.



Applications

Wrapping of archaeological and textile objects, dividers between drawings or photographs, protection of books. It can also be welded to polyester film to produce enclosures with greater airflow.

Product code	Colour	Weight gsm	Size mm x m	Size inches	Pack qty
PANWPRO001	Natural White	40	1000 x 100	39 ³ / ₈ x 3937 ¹ / ₄	Roll
PANWPRO002	Natural White	100	1000 x 20	39 ³ / ₈ x 787 ³ / ₂	Roll
PANWPRO003	Natural White	100	1000 x 100	39 ³ / ₈ x 3937 ¹ / ₄	Roll

Bondina®

WHITE



Non-woven, chemically inert 100% polyester release material used to support fragile items during conservation treatments. Using polyester welding equipment Bondina® can be adhered to a number of materials such as Melinex®/Mylar® polyester, CXD Polyester type 2, paper and board to produce special folders. The 30gsm has a very smooth surface finish.

Applications

- Support of fragile items
- Lining
- Production of special folders

Linked Products: Polyester Welding Equipment p173; Polyester Rolls and Cut Sheets p77; Boards p108; Papers p83.

Product code	Weight gsm	Size mm	Size inches	Pack qty
PABONH3230	30	920 x 10m	36 ¹ / ₂ x 393 ⁵ / ₆₄	1
PABONH0001	30	1000 x 50m	39 ³ / ₈ x 1968 ¹ / ₂	1
PABONH1009	100	1000 x 10m	39 ³ / ₈ x 393 ⁵ / ₆₄	1
PABONH0002	100	1000 x 10m	31 ¹ / ₂ x 393 ⁵ / ₆₄	1



Reemay® Non-Woven Synthetic Fabric

WHITE



Reemay® is made from acid-free, random spun-bonded 100% polyester. It has a proven track record as a strong, inert material which is ideal for a variety of conservation applications. Reemay® is used in paper-infill, interleaving, lining, backing and as a drying support material. Reemay® is more open weave and rougher than Holytex®.

Specifications	Applications
<ul style="list-style-type: none"> • 100% polyester • Acid-free 	<ul style="list-style-type: none"> • Paper-infilling • Interleaving • Backing • Support material

Product code	Weight gsm	Size mm	Size inches	Pack qty
PAREEM2250	17	1219 x 25m	48 x 984¼	1
PAREEM2014	34	1498 x 25m	59 x 984¼	1
PAREEM7100	71	1041 x 25m	41 x 984¼	1

Holytex® – Acid-Free, Non-woven 100% polyester

WHITE



Holytex® is made from acid-free, fine non-woven 100% polyester. It is a very low lint, smooth, high tensile strength material which is used for a wide variety of conservation treatments. It can withstand temperatures up to 175°C. Holytex® is a smoother version of Reemay®.

Specifications	Applications
<ul style="list-style-type: none"> • 100% Polyester • Low lint • Acid-free 	<ul style="list-style-type: none"> • Lining and pasting • Backing • Interleaving • Leafcasting

Product code	Weight gsm	Size mm	Size inches	Pack qty
PAHOLY3242	71	1219 x 25m	48 x 984¼	1
PAHOLY3251	17	1194 x 25m	47 x 984¼	1
PAHOLY3257	34	1016 x 25m	40 x 984¼	1

Synergex® Acid-Free, Non-woven 100% Polyester



Composite polyester release material. Flat-bonded Synergex® has been completely calendered and laminated over the entire media surface, making the finished product more efficient than traditional Reemay® products.

Specifications	Applications
<ul style="list-style-type: none"> • 100% polyester non-woven • Multi-layer construction • Extremely low-fuzz • Acid-free • Product weights: 0.40-6.0 osy (14-200gsm) 	<ul style="list-style-type: none"> • Paper-infilling leafcasting • Lining and pasting • Interleaving • Backing • Support material

Product code	Weight gsm	Size mm	Size inches	Pack qty
PASYNX3425	85	914 x 25m	35¾/₆₄ x 984¼	1
PASYNX8525	85	914 x 25m	35¾/₆₄ x 984¼	1

Feutrex™ Polyester Felt

100% polyester felt and chemically inert. Absorption and cushioning capacities are greater than with blotters and is therefore useful for avoiding excessive flattening of paper fibres while drying under weights. It has proved an excellent liner and protection material for drawers, boxes, packaging where fragile objects must be cushioned.



Product code	Weight gsm	Size mm x m	Size inches	Pack qty
PAFELT0001	700	1000 x 50	39¾ x 1968½	Roll
PAFELT0002	700	1000 x 5	39¾ x 1967½	Roll
PAFELT0003	700	1000 x 25	39¾ x 984¼	Roll

CXD Capillary Matting

WHITE

This 100% polyester composition matting is a binder-bonded, non-woven fabric. Can be wetted to create a reservoir to give uniform humidification and reduce the risk of liquid penetration when used with a Gore-tex® or Sympatex® membrane. It can also be used as a support material, as a surface to dry-washed objects and can be used as blotter to remove excess liquid.



Specifications	Applications
<ul style="list-style-type: none"> • 100% polyester • Non-Woven 	<ul style="list-style-type: none"> • Vacuum tables • Re-usable blotting

Linked Products: Vacuum Tables p168.

Product code	Weight gsm	Size mm	Size inches	Pack qty
PACAMA0160	N/A	915 x 1000	36 x 39¾	Per metre length

Cokon™

Cokon™ is a non-woven material made of polyester, viscose rayon and paper cellulose.

Applications
<i>In conservation it is used to support documents during wet treatments. Wet-resistant Cokon™ provides support to immersed document and easy removal without damage.</i>

Product code	Weight gsm	Size mm x m	Size inches	Pack qty
PACOKO0010	35	900 x 10m	35¼ x 393¾/₆₄	Roll
PACOKO0100	35	900 x 100m	35¼ x 3937/₆₄	Roll

Sympatex®

WHITE

An alternative to Gore-Tex®



A synthetic, moisture-permeable material which can be used for humidification treatments, Sympatex® allows the object to be humidified without wetting. For water-sensitive objects this useful material can be used with humidity for the removal of old linings, residual adhesives and stains.

Specifications
<i>Moisture-permeable synthetic</i>

Applications
<i>Humidification for conservation treatments</i>

Product code	Weight gsm	Size mm x m	Size inches	Pack qty
PASYMPO360	92	1500 x 10	59¼/₁₆ x 393¼/₁₆	Roll
PASYMPO008	92	1500 x 1	59¼/₁₆ x 39¾	1

Tyvek® Types I443R and I082D



An inert (non-woven) polyethylene, Tyvek® is made from spun-bonded polyethylene olefin fibres. It has a paper-like feel but is stronger than paper and will stretch up to 15-25% before breaking. Unaffected by water and therefore dimensionally stable in humid situations, Tyvek® is a thermoplastic material and melts sharply at 135 degrees centigrade (275°F).

Both the Tyvek® I443R and I082D material have an anti-static coating on both sides which can be removed with distilled water. Tyvek® is soft and flexible, gas-permeable, non-abrasive, waterproof and dust-resistant.

Tyvek® type I443R is soft and flexible and it is ideal for making protective covers for museum archive and library objects, as it can be converted into bags, cushions, textile covers etc. It is not susceptible to age- degradation and has many more uses for conservation and preservation.

Tyvek® type I082D is paper-like in appearance and combines the performance of paper, film and fabric and can be used in a wide variety of applications such as printing tags, labels, barriers and signs.

Applications

- Interleaving
- Protective cover
- Hinging
- Labelling

Linked Products: Tyvek® Tape p133, Tyvek® Tags p139.

Product code	Type	Weight gsm	Size mm	Size inches	Pack qty
PATYAR0020	I443R	43	1524 x 20m	60 x 787 ³ / ₈	Roll
PATYAR0100	I443R	43	1524 x 100m	60 x 328ft	Roll
PATYAS0013	I082D	110	420 x 297	16 ⁹ / ₁₆ x 11 ¹¹ / ₁₆	100

Tyvek® I073D

The composition is exactly the same as the softer I443R Tyvek® but it comes in the form of a very strong, smooth, pearly sheet, which is water-resistant and offers good resistance to solvents.

It can be written upon with pencils and a variety of markers.

Applications

This product has many different uses: Object protection, producing envelopes, bookbinding, hinging and portfolio-making. An excellent protective covering to isolate books and objects from direct contact with wooden or painted metal shelves.

Product code	Weight gsm	Size mm	Size inches	Pack qty
PATYAS0001	75	700 x 1000	27 ¹ / ₂ x 39 ³ / ₈	25

Tyvek® Fabric Type I622



Thermally bonded 100% polyethylene fibres. Chemically neutral, light and resistant to moisture and chemicals. Tyvek® I622 is untreated, soft, flexible and is micro-perforated. Natural White colour. It may be sewn like fabric or bonded using Criss Cross heating sealers.

Applications

For use as protective covers for museum artefacts, textiles, soft furnishings, tapestries, etc. and provides a barrier against dust and mould spores.

Product code	Weight gsm	Size mm x m	Size inches	Pack qty
PATYAR0030	43	1520 x 30m	59 ⁷ / ₃₂ x 98ft 5 ¹ / ₄	Roll

Synthetic Materials and Heat-Set Lamination

Area Bonded Fibre™ – Heat-Set



A highly flexible nylon fibre lamination material with good transparent qualities particularly suited to repairs where material has a high usage. May be cut for strip section repairs using a heated spatula. For application by heated press use at 80–90°C (174–196°F) with a 20–30 second dwell-time. Spirit reversible.

Product code	Size mm	Size inches	Pack qty
SUABFI0010	1016 x 10m	40 x 393 ⁵ / ₆₄	1
SUABFI0100	1016 x 100m	40 x 3937 ¹ / ₆₄	1

Archival Cloth™ with Texicryl Adhesive – Heat-Set



An archival coated 100% cotton-bleached cloth containing an anti-fungicide coated on one side with the Archibond™ adhesive. Best applied using a hardbed or power press at 80–90°C (176–194°F) and between 20–30 seconds dwell-time. For the backing of maps, charts and posters or to reinforce joints. Spirit reversible.

Product code	Size mm	Size inches	Pack qty
SUACTA1240	1240 x 1000	48 ¹³ / ₆₄ x 39 ³ / ₈	1
SUACTA7055	1240 x 10m	48 ¹³ / ₆₄ x 393 ⁵ / ₆₄	Roll

Archibond™ Tissue – Heat-Set



A 100% Manilla CXD Spider tissue, pure base weight 9.3gsm coated with a heat-set, paraloid, acrylic adhesive. Excellent clarity and strength characteristics and is ideal for full and localised repair of papers and books. May be applied using a tacking iron or with a suitable press. For application by heated press use at between 80–90°C (176–194°F) with a 15–25 second dwell-time. Spirit reversible.

Product code	Description	Size mm	Size inches	Pack qty
SUARCH0010	Heat Laminating Tissue	955 x 10m	37 ¹⁹ / ₃₂ x 393 ⁵ / ₆₄	Roll
SUARCH0100	Heat Laminating Tissue	955 x 100m	37 ¹⁹ / ₃₂ x 3937 ¹ / ₆₄	Roll

Unsupported Archibond™ Heat-Set



An 18-micron thick layer of pure Archibond™ acrylic adhesive coated onto a release liner for coating other paper, tissue and material substrates using heat. Best applied using a hardbed, vacuum or power press at 80–90°C (176–194°F) initially for 10–15 seconds and finally for 20–30 seconds. Spirit reversible.

Product code	Weight gsm	Size mm	Size inches	Pack qty
SUUARCO100	18	1040 x 100m	40 ⁵ / ₁₆ x 3937 ¹ / ₆₄	1
SUUARCO010	18	955 x 1000	37 ¹⁹ / ₃₂ x 393 ⁵ / ₆₄	1



Linked products: Heated spatulas p162-163; Hot Press p171 and Semi-matic Laminators p170.

Corrosion Protection and Barrier Materials

Reactive Intercept Barrier System (RIBS) Foil

Moisture and oxygen-barrier film with off-gassing interceptor.

Reusable packaging system with permanent electrostatic protection and a self-contained de-ionizer for corrosive gases. The outer side of the film is carbon-conductive polymer, whilst the inside layer is Corrosion Intercept® which prevents the ingress of moisture. It also neutralises atmospheric pollutants and oxidising gases.

The construction of this high-specification material combines an outer layer of tough polypropylene with an aluminium foil and an interior layer of Corrosion Intercept®. This makes the material highly durable and, when sealed, the contents are cocooned within an environment that is impervious to moisture, oxygen, atmospheric pollutants and oxidising gases. When sealed (preferably with partial vacuum) this rapidly produces a microclimate within the bag that is dry and free of atmospheric corrosive gases.

Unlike traditional scavengers such as charcoal and micro-sieves, the inner layer of Intercept does not simply trap gases and pollutants, it reacts with and neutralises them permanently. The material was initially developed for use in aerospace and data storage where material off-gassing is a major concern, so it has been designed to be ultra-low off-gassing and is ironically very clean. The Corrosion Intercept® layer is inherently anti-static and also acts as a passive bactericide fungicide.

Applications

Storage of:

- Photographs and film
- Silver
- Copper
- Brass
- Paper
- Textiles
- Framing and artwork

Product code	Description	Size mm	Size inches	Pack qty
SURIBS1219	RIBS Foil MVTR	1219 x 10m	47 ³⁵ / ₆₄ x 393 ⁵ / ₆₄	Roll

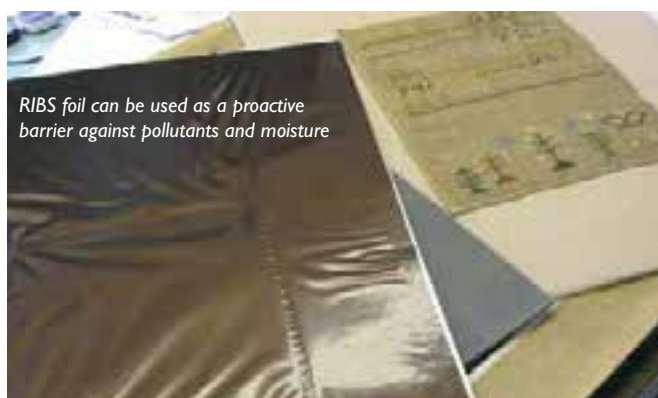

RIBS foil can be used as a proactive barrier against pollutants and moisture

Corrosion Intercept Technology™

Moisture and oxygen-barrier film with off-gassing interceptor. (Reactive Intercept Barrier System – RIBS)



- State of the Art in Corrosion Protection
- Developed by Lucent Technologies Bell Labs
- Distributed by Conservation by Design Limited

CORROSION INTERCEPT® is a revolutionary, patented technology which uses semi-conductor technology to transform plastic into a protective reactive barrier against corrosive gases, fungus and bacteria. It is comprised of highly reactive copper particles bonded into a polymer matrix. This matrix film forms a preferential corrosion site that reacts and neutralises all corrosive gases that pass through or come in contact with the film. It is statistically improbable that they can migrate through the intercept film without contacting and reacting with one of the active corrosion sites. **CORROSION INTERCEPT®** provides a unique and effective protection for copper, silver, brass, bronze, ferrous and non-ferrous metals. It has also been successfully used to protect CDs, photographic prints, film, textiles, paintings, books and other works of art on paper. This inert material does not give off any harmful gases and is unaffected by moisture, humidity or temperature and it has a built-in saturation indicator.

When the copper colour turns it is time to change the Intercept. The protection against corrosion is approximately 10 years per 0.025mm thickness of INTERCEPT.

www.intercept-technology.com

Corrosion Intercept® Film and Bags

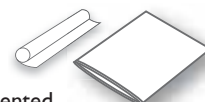

Corrosion Intercept® (CI) is a revolutionary, patented technology which uses semi-conductor technology to transform plastics into a protective reactive barrier against corrosive gases, fungus and bacteria.

With built-in saturation indicator.

Please request a technical data sheet for more information.



SUCIFM Roll



SUCIZB Bags

Product code	Description	Size mm	Size inches	Pack qty
SUCIFM0500	C.I. Film Roll	152 x 1219	47 ³⁵ / ₆₄ x 5984 ¹ / ₄	Roll
SUCIFM1219	C.I. Film Roll	10 x 1219	47 ³⁵ / ₆₄ x 393 ⁵ / ₆₄	Roll
SUCIOB0406	Bags - open top	152 x 102	6 x 5	1
SUCIOB0609	Bags - open top	152 x 229	6 x 9	1
SUCIOB0810	Bags - open top	203 x 254	8 x 10	1
SUCIOB1012	Bags - open top	254 x 305	10 x 12	1
SUCIOB2024	Bags - open top	508 x 610	20 x 24	1
SUCIZB0810	Bags - zipper-style top	203 x 254	8 x 10	1
SUCIZB1012	Bags - zipper-style top	254 x 305	10 x 12	1

Purification Paint®

A charcoal black liquid paint consisting of activated carbon in an aqueous dispersion with sodium carbonate and acrylic polymer. Purification Paint® is designed to protect against deterioration caused by gaseous atmospheric pollution or harmful volatile substances, which may migrate from materials such as wooden frame rebates, wooden plan chests, transit cases or display cabinets. It can also be used to paint over acid board which cannot be replaced such as an old backing board within a frame, covering an acid mount bevel or painting the inside of old containers such as lantern slide boxes. Stir well before use.



Product code	Description	Capacity ml	Pack qty
SUPURP0001	Purification Paint®	750ml Jar	1

Activated Charcoal Cloth®

Activated Charcoal Cloth® (ACC) is a unique form of carbon which is 100% pure activated charcoal in a woven textile configuration. It is a highly efficient filter media with a high capacity for absorption of a wide range of organic vapours, pollutants and odours. ACC is available in three formats and is supplied by the linear metre with a guaranteed minimum width of 95cm. Due to its textile form it can be easily cut to fit storage and display cases or to line the backboards of paintings, drawings and textiles. Its flexibility means it can be pleated or sewn if required.

Applications

- Lining display cases, boxes, picture frames etc

Link to: Purification Paint page 107.

Product code	Description	Size mm	Size inches	Pack qty
SUACCP0000	Plain 100% Pure Cloth	W: 950	37 ¹ / ₂	Per mtr length
SUACNW0001	Viscose Non-woven. Bonded 1 Side Cloth	W: 950	37 ¹ / ₂	Per mtr length
SUACNW0002	Viscose Non-woven. Bonded 2 Side Cloth	W: 950	37 ¹ / ₂	Per mtr length



Aluminium Vapour Barrier Complex

Humidity, polluting gases and dust are the main factors capable of damaging art objects. This industrial product is a composite material based on aluminium foil made into a complex lamination of polyester and polyethylene. It can be heat-sealed with a CXD Criss Cross welder to ensure highly efficient moisture protection of box interiors for artwork or museum objects during shipping. It is also useful for making envelopes and dust covers and as a moisture-barrier in picture frames. It is commonly specified for covering and encapsulating wooden surfaces in showcases in order to act as a barrier against acetic acid and other corrosive gases emanating from the wood. It can be made into pouches suitable for vacuum-packing or anoxic storage and pest-eradication treatments.

Product code	Weight gsm	Size mm	Size inches	Pack qty
SUALUM0001	142	1500 x 10m	59 ¹ / ₁₆ x 393 ⁵ / ₆₄	Roll
SUALUM0002	142	1500 x 100m	59 ¹ / ₁₆ x 3937 ¹ / ₆₄	1
SUALUM0003	270	1500 x 10m	59 ¹ / ₁₆ x 393 ⁵ / ₆₄	1
SUALUM0004	270	1500 x 100m	59 ¹ / ₁₆ x 3937 ¹ / ₆₄	1

Linked Products: Vacuum Packing Machine p105, 106 and 166-168; Monitoring Equipment p181 and 191-192, Silica Gel p190, Oxygen Scavengers p182.

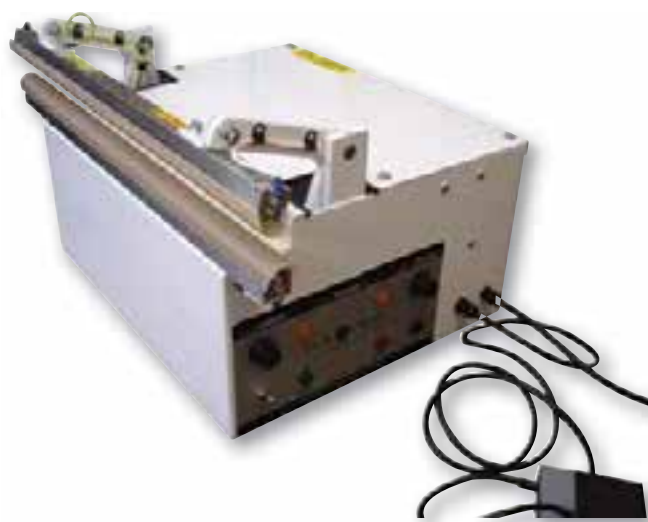

Moistop Barrier foils

Barrier foils are a 3 or 4-ply laminate consisting of polyester, aluminium foil and polyethylene, which are used to prevent corrosion and moisture damage. The key to the product is the aluminium foil layer which acts as a gas barrier making the laminate a form of flexible 'tin can'. Often used for lining showcases as a barrier against gas emissions from wood or MDF board.

Product code	Description	Size mm	Size inches	Pack qty
SUMSPP5100	Roll PP005	W 1000 x 200m	39 ³ / ₈ x 7874 ¹ / ₆₄	1 Roll
SUMSPP5125	Roll PP005	W 1250 x 200m	49 ⁷ / ₃₂ x 7874 ¹ / ₆₄	1 Roll
SUMSPP5150	Roll PP005	W 1500 x 200m	59 ¹ / ₁₆ x 7874 ¹ / ₆₄	1 Roll

Boards

The Conservation By Design Board Collection

The Conservation By Design range of boards in this catalogue have been developed over many years. They have clearly defined specifications and are produced under controlled manufacturing conditions allowing those responsible for conserving and preserving the collections of Museums, Galleries, Libraries and Archives to confidently select these products for their application.

'Board' is a broad term that incorporates everything from a thick paper to honeycomb panels. Mostly when we think of board we think of paper-based items but, in this catalogue, it can include synthetic materials such as Plastazote® polyethylene foam or composite materials like Gatorfoam®, which combines paper with polystyrene foam.

Paper-based board can be made with or without adhesive; the method of manufacture chosen will depend on the end-user application. We offer boards for making storage boxes and folders, supporting, mounting and framing objects as well as boards for bookbinders. Although CXD specialise in boards of the highest archival specification, for applications where this level is not required we have included a selection of lower quality boards.

Non-adhesive Laminated Paper Board

The earliest forms of paper board were made in handmade paper mills. In Japan these thicker multi-layer papers are known as Tamishiguchi. In Europe little is known about the manufacture of these early 'pasteless' boards other than they were produced in varying thicknesses by laying one or several wet layers of pulp on top of each other so that the wet fibres bonded together. They were then pressed and dried.

Renaissance Revisited

In 2007 Conservation By Design initiated a project with Jacques Brejoux, of the Moulin du Verger (MDV) handmade paper mill and Christopher Clarkson, (rare book conservator and conservation consultant to Hereford Cathedral, Wordsworth Trust and the Bodleian Library in Oxford) to develop boards and cover papers of similar quality to those found on early Renaissance bindings. The resultant MDV papers and boards can be found in this catalogue and are the product of many years' combined experience and dedication to the production of authentic materials of the finest quality.

Millboard

If a hard, dense board is required, such as for post-19th-century bookbinders' millboard, it is normally made without adhesive on an 'Intermittent' board machine. This kind of machine forms the board around a large drum by building up layers of wet pulp until the

desired thickness is achieved. The board is then pressed and dried. It is sometimes known as 'Pressboard' or 'Transformer Board'. This method of manufacture is capable of producing very hard, dense board and often uses recycled material. The typical density range is 0.96g/cm³ to 1.30g/cm³.

In the 19th century old hemp rope, which also contained elements of tar, was used to make an extremely hard board which was very popular with bookbinders. Apart from bookbinding, boards made by this method can be used for picture backing boards and boxmaking. They are also used for the shoe, automotive and electrical industries. Most of the mills using this kind of machinery are not suitable for making high-quality archival binding or storage board. However, there are one or two specialist mills still in existence that are capable of producing a high-quality product and Conservation By Design use such a mill to produce 'Superior Millboard™' and 'EcopHant Boxboard™'.

Although these boards use recycled waste they are acid and lignin-free as they are made solely from CXD archival quality, post-production paper and board waste created during the manufacture of our Premier Duo™ Archival Board, Boxes, Folders and Envelopes.

The 'Intermittent' board machine is inflexible and cannot make the variety of colours and surface finishes that can be achieved by laminating layers of paper with adhesive and, because of the high density of the product, it is also very hard to cut. This makes it unsuitable for producing mountboard for artwork.

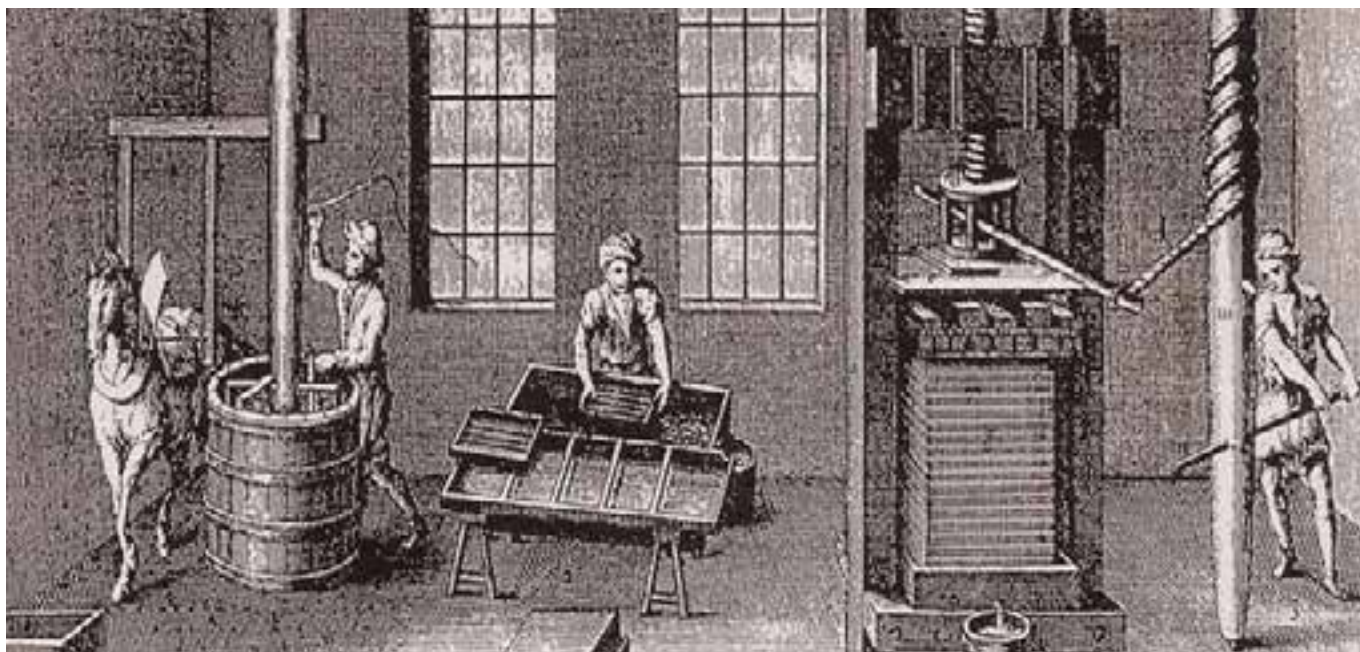

18th-century boardmaking by hand. The image comes from Joseph Jérôme Le Français de Lalande, *L'Art du Cartonnier*, published in 1762, and shows pulping using a horse-powered pulper, forming the sheets of board and pressing boards. Courtesy of Bower Collection

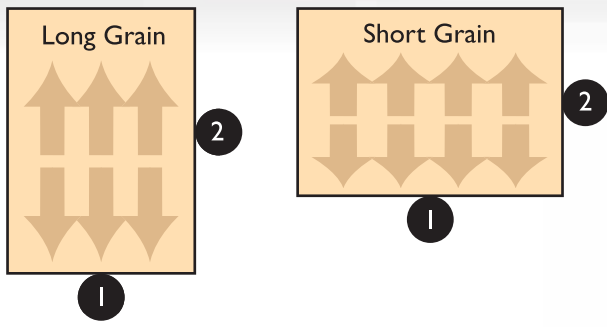

Grain Direction

When listing sizes we endeavour to use the established trade method of showing sheet sizes to denote grain direction.
 Short edge first = long grain.
 Long edge first = short grain.

Examples of Moulin du Verger Multi-layer Renaissance Cover Paste Board (p91-93)

Adhesive Laminated Paper Board

The most flexible method of manufacturing boards for mounting, framing and storage/boxes is to glue two or more sheets together on a laminating machine. This allows papers and textures to be combined to create an infinite variety. Paper and foils can also be used for special applications. Corrugated board is also laminated but the inner core is fluted to create thickness without density.

As an intrinsic part of the board CXD pay particular attention to any adhesive used for laminating the plies of paper together. The first quality Museum, Conservation Mounting and Premier Duo™ Archival Folding Boxboards are made using 'Evacon-R™', an EVA adhesive. A PVA adhesive with Neutral pH is used for the second quality boards.

EVA is a much more expensive adhesive than PVA but has proved more resistant to acid hydrolysis and contains no plasticisers. For the range of corrugated boards we use a starch adhesive. Due to the difficulty in controlling moisture-content, starch is now rarely used commercially for producing mountboards. In the past, many boards were laminated with hot animal glue and can be identified by the brown glue line between each layer of paper.

Paper can be glued together on either a reel-to-reel laminator or a sheet-to-sheet laminator or a sheet-to-reel laminator.

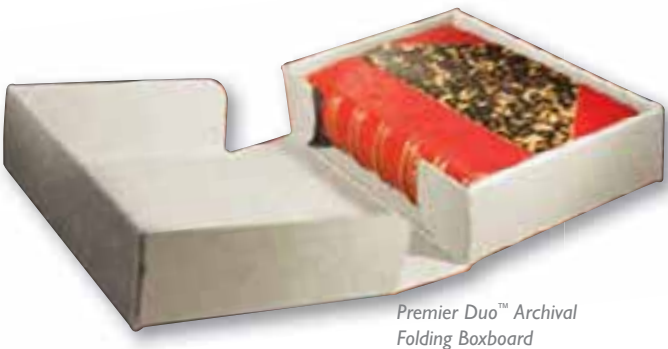

Premier Duo™ Archival Folding Boxboard

Mountboards



CXD Sample Swatch Service

Boards: BDAFSB0001
 Mountboards: BDTHSB0002
 Papers: PAHPSB0003



The colour reproduction of papers and boards in this catalogue is a guide only. Sample swatches are available for colour-matching purposes from CXD.



Premier Duo™ Archival Folding Boxboard – Solid Centre

A combination of strength and purity - permanent and durable.

This duplex colour, solid centre conservation boxboard is designed for the production of solid board boxes and folders to protect collections from the damage caused by handling, atmospheric pollution, fire and flood disasters. The board is laminated from Conservation by Design Heritage Archival pHotokraft™ Papers which pass the Silver Tarnish Test and Photographic Activity Test (PAT). They are acid-free and lignin-free, with a high percentage of bleached long kraft fibres. This board which meets the most stringent requirements of long-term archival storage for conversion into boxes or folders is laminated with EVA plasticiser-free adhesive which is more resistant to acid hydrolysis than other cheaper synthetic adhesives. This is important if you are looking for the maximum level of protection because, if the adhesive breaks down and 'off-gasses' in the micro-environment of a box, the contents can be damaged.

Premier Duo™ Archival Folding Boxboard - Solid Centre offers a controlled 'micro-environment' for books, papers, photographs and other fragile items; adding to the physical protection a slightly alkaline environment helps to counteract any acidity in boxed materials. Reducible sulphur content of the board comfortably meets the ANSI American standard for the safe storage of photographic materials. The greatest care has gone into ensuring that this material meets detailed archival standards in terms of chemical composition whilst offering excellent folding strength and rigidity. The coloured paper surface of the board will not bleed and is resistant to fading, dirt, grease and abrasion, while the smooth, white interior surface is designed to minimise abrasion of box contents.

Please note: Products made from corrugated board do not offer the same protection from fire or water as Solid Centre Board.

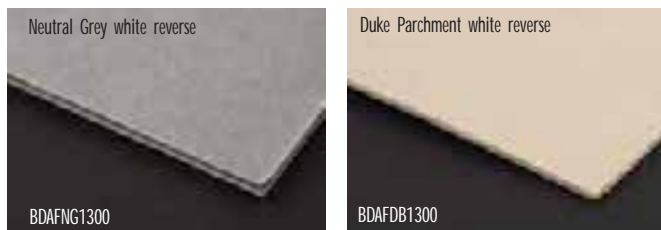

Specifications

- Acid-free pH7.5 to 9.5
- Permanent and durable quality ISO 16245-A Type A
- Lignin-free (ASTMD 1030),
- Lightfast – min 5 Blue Wool Scale test (BS1006:97 and TAPPI T475)
- Internally sized with Alkyl Ketene Dimer (AKD)
- Externally sized with non-ionic, farina starch
- Buffered (average 3%) calcium carbonate (ISO 9706)
- Reducible sulphur: less than 0.8 parts per million (TAPPI T406)
- Specified free of optical brightening agents (OBAs)
- Passes Photographic Activity Test (PAT) (ISO 18916)
- Photo-safe conforms to (ISO 18902:2007(E))
- Evacon-R™ EVA lamination adhesive contains no plasticisers



Applications

- Boxmaking
- Archive storage boxes – die-cut
- Folders and portfolios
- Custom Kasemake CXD phase boxes
- Support boards
- Liners
- Model-making



Uses

- 300 micron for folders, 650 micron for boxmaking; folders, portfolios, small phase boxes
- 1000 micron for boxmaking, folders, medium phase boxes
- 1300 – 1625 micron for boxmaking, large phase boxes
- 1625 micron for boxmaking, large phase boxes, portfolios
- 2000 micron for boxmaking, large portfolios etc
- Model-making

Linked Products: Boxes section p7, Bookmeasure Kasemake p175-176; RollingBoard Creaser p176; Board Chopper p157; Mount Cutters p153; Washers p124; Rivets p111, 124.

Product code	Colour duplex	Thickness mm	Sheets/1000kg	Size mm	Size inches	Pack qty
BDAFNG0300	Neutral Grey/White	0.3	5290	1040 x 780	40 ¹⁵ / ₁₆ x 30 ¹¹ / ₁₆	50
BDAFNG0650	Neutral Grey/White	0.65	1205	1040 x 1473	40 ¹⁵ / ₁₆ x 58	20
BDAFNG1000	Neutral Grey/White	1	806	1040 x 1473	40 ¹⁵ / ₁₆ x 58	12
BDAFNG1300	Neutral Grey/White	1.3	625	1040 x 1473	40 ¹⁵ / ₁₆ x 58	10
BDAFNG1338	Neutral Grey/White	1.3	1360	700 x 1000	27 ⁷ / ₁₆ x 39 ⁷ / ₁₆	10
BDAFNG1625	Neutral Grey/White	1.625	516	1040 x 1473	40 ¹⁵ / ₁₆ x 58	10
BDAFNG1626	Neutral Grey/White	1.625	1042	700 x 1000	27 ⁷ / ₁₆ x 39 ⁷ / ₁₆	10
BDAFBD0650	Duke Parchment/White	0.65	1205	1040 x 1473	40 ¹⁵ / ₁₆ x 58	20
BDAFBD1000	Duke Parchment/White	1	806	1040 x 1473	40 ¹⁵ / ₁₆ x 58	12
BDAFBD1300	Duke Parchment/White	1.3	625	1040 x 1473	40 ¹⁵ / ₁₆ x 58	10
BDAFNG2001	Neutral Grey/White	2.01	595	800 x 1200	31 ¹ / ₂ x 7 ⁷ / ₈	10
BDAFNG2002	Neutral Grey/White	2.01	297	1200 x 1600	47 ¹ / ₄ x 62 ³ / ₄	5

Also available in pallet qty. A sample swatch is available.

Premier™ 'Bookshoe' Boxboard – Solid Colour

This solid colour boxboard is made to the same high specification as the Premier™ Archival Folding Boxboard, but is a solid colour throughout. This board has been manufactured in a lightfast Sepia/Brown colour and is used mainly for the production of unobtrusive protective 'bookshoes' for leather bindings in antique or specialist libraries.

As with the Premier™ Archival Folding Boxboard, this board meets the most stringent requirements of long-term archival storage for conservation into bookshoes, boxes or folders and only Evacon-R™ an EVA plasticiser-free adhesive is used in its manufacture.

Linked Products: Cotton Linen Tape p135.

Product code	Colour	Thickness mm	Sheets/1000kg	Size mm	Size inches	Pack qty
BDAFSB1000	Sepia (Solid Colour)	1	870	1040 x 1473	58 x 40 ¹⁵ / ₁₆	12
BDAFSB1300	Sepia (Solid Colour)	1.3	620	1040 x 1473	58 x 40 ¹⁵ / ₁₆	10

A sample swatch is available.



The colour reproduction of papers and boards in this catalogue is a guide only. Sample swatches are available for colour-matching purposes from CXD.

Premier Duo™ Archival Fluted Boxboard

Premier Duo™ Archival Fluted Boxboard is a high-quality, corrugated board made from the same acid and lignin-free, long-fibred conservation quality paper used to make the solid centre Premier Duo™ Archival Folding Boxboard. Offered in 3 styles of flute construction.

Because of its fluted structure, corrugated board has the advantages of being lightweight yet rigid. It has many applications and is particularly useful for oversized boxes.

Conservation By Design's Heritage Archival pHotokraft™ Papers (HAPK) are used to make this board, which meet European and American standards for Archival Long-life Papers and Boards. Suitable for the long-term storage and conservation of documents and photographs, these HAPK papers pass the PAT test and have excellent water-resistance having been internally sized with AKD and externally with starch. The high percentage of long kraft fibres gives enhanced fold and tear strength to the board.

Please note: Corrugated boxes, when produced in volume, offer a lower cost and good protection against handling. This is why they are used for commercial packaging/shipping and display applications. However, products made from corrugated board do not offer the same protection against water and fire as solid centre boxboard.

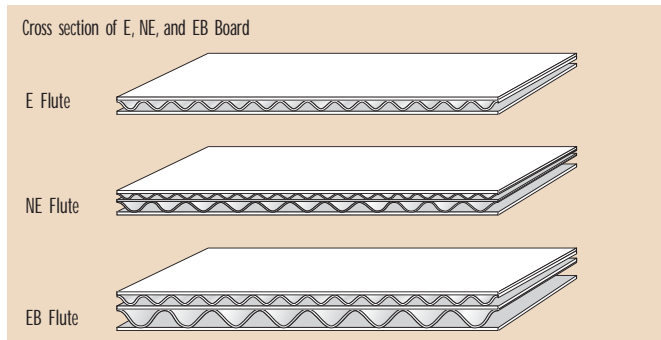

Specifications

- Acid-free pH7.5 to 9.5
- Lignin-free (ASTM D 1030)
- Kappa no. <5 (ISO302)
- Lightfast – min 5 Blue Wool Scale test (BSI 006:97 and TAPPI 475)
- Internally sized with Alkyl Ketene Dimer (AKD)
Externally sized with non-ionic farina starch
- Buffered (average 3%) calcium carbonate (ISO 9706)
- Reducible Sulphur: less than 0.8 parts per million (TAPPI 406)
- Specified free of optical brightening agents (OBAs)
- Passes Photographic Activity Test (PAT) (ISO 18916)
- Alkaline pH starch adhesive



Applications

- Boxmaking, die-cutting and creasing
- Archive storage boxes
- Folders and portfolios
- Support boards
- Liners
- Model-making

Linked Products: Bookmeasure Kasemake p175-176; Rolling-Board Creaser p176; Rotatrim® p155; Board Chopper p157.

Product code	Flute	Colour duplex	Thickness mm	Sheets/1000kg	Size mm	Size inches	Pack qty
BDCORE7411	E	Grey/White	1.8	1587	820(flute) x 1225(grain)	32 ¹ / ₁₆ x 48 ¹ / ₄	20
BDCORE7412	E	Grey/White	1.8	787	1640(flute) x 1225(grain)	64 x 48 ¹ / ₄	20
BDCORE7413	E	Grey/White	1.8	394	1640(flute) x 2450(grain)	64 x 96 ¹ / ₁₆	20
BDCORE7811	NE	Grey/White	2.2	1538	820(flute) x 1225(grain)	32 ¹ / ₁₆ x 48 ¹ / ₄	20
BDCORE7812	NE	Grey/White	2.2	763	1640(flute) x 1225(grain)	64 x 48 ¹ / ₄	20
BDCORE7813	NE	Grey/White	2.2	513	1640(flute) x 2450(grain)	64 x 96 ¹ / ₁₆	20
BDCORE7612	EB	Grey/White	4.4	476	1640(flute) x 1225(grain)	64 x 48 ¹ / ₄	10
BDCORE7613*	EB	Grey/White	4.4	239	1640(flute) x 2450(grain)	64 x 96 ¹ / ₁₆	10

Also available in pallet qty. A sample swatch is available. Please note these products may incur additional handling/packing charges *Available on request, smaller sheet sizes 820 x 1225mm.



PolypHlute™ Corrugated Polypropylene + Polyethylene

pH neutral, fluted plastic panels made with a copolymer of approximately 90% polypropylene and 10% polyethylene. Lightweight and waterproof, these panels have numerous applications such as making boxes, drawer partitions, shelf coverings, exhibition supports, picture-frame backing etc.



PolypHlute™ boards can be cut, grooved, folded, pierced and joined using PolypHlute™ rivets.

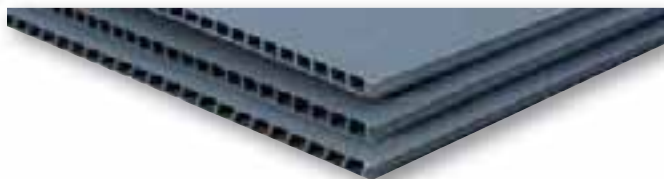

Product code	Colour	Size mm	Size inches	Thickness mm	Pack qty
BDCORP0001	Grey	1000 x 1400	39 ¹ / ₁₆ x 55 ¹ / ₁₆	3.3	5
BDCORP0005	Grey	1000 x 1400	39 ¹ / ₁₆ x 55 ¹ / ₁₆	4	5
BDCORP0002	Grey	800 x 1200	31 ¹ / ₂ x 47 ¹ / ₄	2.4	5
BDCORP0003	Grey	1250 x 1830	49 ⁷ / ₃₂ x 72 ³ / ₆₄	3.3	5
BDCORP0004	Grey	820 x 1200	32 ⁷ / ₃₂ x 47 ¹ / ₄	3.3	5

PolypHlute™ Rivets



Rigid, two-part polypropylene rivets for joining PolypHlute™ panels. Simply press together to the desired thickness and trim off any excess that might protrude.



Applications

- Useful for fixing fluted or solid core boards together when making boxes or displays

Product code	Size mm	Size inches	Pack qty
SURIVE0015	15	1 ¹ / ₂	100 rivets

Handmade Bookbinders Board and Millboard

Moulin du Verger, Wet, Laid, Multi-Layered, Pasteless Bookbinders' Board

The Moulin du Verger Paper Mill has been in existence since 1539. Its current master, Jacques Brejoux, has dedicated his life to the papermaker's art and learning the secrets of the antique papermakers. The mill produces 14th to 19th-century facsimile papers and boards which are suitable for bookbinding, restoration, conservation and fine art. In order to make these unique papers and boards available to a wider audience CXD have been working with Moulin Du Verger and are now exclusive distributors and stockists. In addition to the stock range special makings are undertaken to customers' requirements.

Handmade bookbinders board is made by couching one wet sheet upon another until the desired thickness is achieved. Available in a variety of thicknesses, it is made for the finest rare book and conservation bindings. The pulp is made from recycled, handmade paper and is designed to be dimensionally stable and have good cross-ply bonding.



Applications

- Bookbinding
- Restoration
- Conservation and Fine Art

Linked Products: Linen Bookbinding Cord p131, Evacon-R™ p127.

Product code	Colour	Thickness mm	Size mm	Size inches	Pack qty
BDHMMB1509	Various	1.5	440 x 560	17 ⁵ / ₁₆ x 22 ¹ / ₁₆	1
BDHMMB1210	Various	1.2	440 x 560	17 ⁵ / ₁₆ x 22 ¹ / ₁₆	1
BDHMMB1510	Various	1.5	440 x 560	17 ⁵ / ₁₆ x 22 ¹ / ₁₆	1
BDHMMB1810	Various	1.8	440 x 560	17 ⁵ / ₁₆ x 22 ¹ / ₁₆	1
BDHMMB2010	Various	2	440 x 560	17 ⁵ / ₁₆ x 22 ¹ / ₁₆	1
BDHMMB2309	Various	2.3	440 x 560	17 ⁵ / ₁₆ x 22 ¹ / ₁₆	1



Traditional wooden stampers at Moulin du Verger



The CXD Papermaking and Binding Workshop at Moulin du Verger See Papers page 83 and Workshop page 3.

Superior Millboard™

- Archival Quality • Acid-Free • Lignin-Free

Conservation By Design's Superior Millboard™ is acid and lignin-free, made exclusively from archival quality paper and CXD Premier Duo™ Archival Folding Boxboard waste. This waste is created during production and conversion and is used so as to ensure consistent quality and the finest specification of materials. A specification of this waste is given for CXD Premier™ Archival Folding Boxboard, and Heritage Archival pHotokraft™ paper.

The basic construction being chemically purified 100% wood-free, long-fibred, bleached kraft which is acid-free, lignin-free, OBA-free and is buffered with calcium carbonate. The green colour is light-resistant and bleed-proof. The board is of high-density, hard-rolled, traditional, bookbinding quality made exclusively for Conservation By Design.



Specifications

- pH7.5 to 9.5
- 100% recycled archival paper and board waste
- 100% chemically purified wood-free fibre
- Acid-free
- Lignin-free
- OBA-free
- Bleed-proof
- Lightfast
- Density 1.1
- Passes Photographic Activity Test (PAT) (ISO 18916)
- Long grain



Applications

- Bookbinding
- Boxmaking
- Backing Board



Elephant Green

Linked Products: 7 in 1 Bookbinding Table p151, Creaser p176; Schimanek Heavy-Duty Guillotine p158; Rotatrim® p158.

Product code	Colour	Thickness mm	Sheets/1000kg	Size mm	Size inches	Pack qty
BDSMBE1171	Elephant Green	1.1	827	780 x 1280	30 ¹ / ₁₆ x 50 ³ / ₁₆	15
BDSMBE1571	Elephant Green	1.5	607	780 x 1280	30 ¹ / ₁₆ x 50 ³ / ₁₆	10
BDSMBE1971	Elephant Green	1.9	479	780 x 1280	30 ¹ / ₁₆ x 50 ³ / ₁₆	7
BDSMBE7215	Elephant Green	2.3	413	780 x 1280	30 ¹ / ₁₆ x 50 ³ / ₁₆	6
BDSMBE7199	Elephant Green	3	303	780 x 1280	30 ¹ / ₁₆ x 50 ³ / ₁₆	5

A sample swatch is available. Other callipers available to special order.



Mounting Boards

Timecare® Heritage Museum – CottonCore

'Abeat hinc in Aeternum'

Designed for conservation, this 100% Cotton Museum Board has set the standard for the highest specification of museum mounting since the early 1980s and from that time has been the board of choice for major museums in Great Britain and Europe. Cotton is 'born' pure being almost 100% pure alpha cellulose and therefore requires less processing than wood-sourced fibres.

Specified by the founder of Conservation By Design, it was the world's first board to be laminated with EVA plasticiser-free adhesive which is more resistant to acid hydrolysis than other cheaper synthetic adhesives. This is important if you are looking for the maximum level of protection because, if the adhesive breaks down and 'off-gasses' in the micro-environment of a frame or a box, the object enclosed may be damaged. The board passes the PAT and Silver Tarnish Test and is therefore suitable for all media including photographs. This board combines the utmost purity with excellent cutting and erasion properties. Surface absorption is appropriate for washline mounts because of the special sizing applied to the surface of the paper.

For mounting certain types of photograph such as gelatine, albumen and dye transfer prints, which prefer a less alkaline environment, TG - Off White and Dull White is offered in an unbuffered version.

Unbuffered boards are also used by textile conservators for the mounting and storage of wool and silk.

The standard alkaline buffered board is available in Museum Cream, Warm Cream, White and Black.

Applications

- Museum mounting of prints, drawings and photographs
- Conservation framing
- Museum exhibition and display
- Photographic storage and conservation
- Boxmaking and bookbinding
- Library conservation

Specifications

- pH7.5 to 9
- 100% cotton fibre
- Free from acid, lignin and sulphur
- Buffered with calcium carbonate (except TG Off White and Dull White - unbuffered)
- Internal-sized AKD
- Surface-sized (pure, non-ionic, farina starch)
- Specified free of optical brightening agents (OBAs)
- Lightfast - min 5 Blue Wool Scale test (BS I 006:97 and TAPPI T475)
- Passes Silver Tarnish Test (ASTM D2043)
- Passes Photographic Activity Test (PAT) (ISO 18916)
- Fine Art Trade Guild (FATG), museum-level
- Evacon-R™ EVA plasticiser-free laminating adhesive
- Packed in protective, gold polyethylene bags



LONG LIFE



ISO 9706



ISO 18916



Museum Mountboard Callipers

0.55mm

1.10mm

1.65mm

2.20mm

Product code	Colour	Thickness mm	Sheets/1000kg	Size mm	Size inches	Pack qty
BDTHMA3301	White	0.55	2326	1189 x 841	47 x 33	20
BDTHMC3301	White	1.65	781	1189 x 841	47 x 33	5
BDTHMC4701	White	1.65	389	1682 x 1189	66 x 47	5
BDTHMD3301	White	2.20	575	1189 x 841	47 x 33	5
BDTHMD4701	White	2.20	287	1682 x 1189	66 x 47	5
BDTHMA3303	TG Off White*	0.55	2326	1189 x 841	47 x 33	20
BDTHMB3303	TG Off White*	1.10	1111	1189 x 841	47 x 33	10
BDTHMC3303	TG Off White*	1.65	781	1189 x 841	47 x 33	5
BDTHMC4703	TG Off White*	1.65	389	1682 x 1189	66 x 47	5
BDTHMD3303	TG Off White*	2.20	575	1189 x 841	47 x 33	5
BDTHMD4703	TG Off White*	2.20	287	1682 x 1189	66 x 47	5
BDTHMA3304	Dull White*	0.55	2326	1189 x841	47 x 33	20
BDTHMB3304	Dull White*	1.10	1111	1189 x 841	47 x 33	10
BDTHMC3304	Dull White*	1.65	781	1189 x 841	47 x 33	5
BDTHMD3304	Dull White*	2.20	575	1189 x 841	47 x 33	5
BDTHMD4704	Dull White*	2.20	287	1682 x 1189	66 x 47	5
BDTHMA3307	Museum Cream	0.55	2326	1189 x 841	47 x 33	20
BDTHMB3307	Museum Cream	1.10	1111	1189 x 841	47 x 33	10
BDTHMC3307	Museum Cream	1.65	781	1189 x 841	47 x 33	5
BDTHMC4707	Museum Cream	1.65	389	1682 x 1189	66 x 47	5
BDTHMD3307	Museum Cream	2.20	575	1189 x 841	47 x 33	5
BDTHMD4707	Museum Cream	2.20	287	1682 x 1189	66 x 47	5
BDTHMC3308	Warm Cream	1.65	781	1189 x 841	47 x 33	5
BDTHMD3308	Warm Cream	2.20	575	1189 x 841	47 x 33	5
BDTHMA3311	Black	0.55	2326	1189 x 841	47 x 33	20
BDTHMC3311	Black	1.65	781	1189 x 841	47 x 33	5
BDTHMD4711	Black	2.20	287	1682 x 1189	66 x 47	5

*Unbuffered

Separate mountboard swatch available. ZLIT003



White

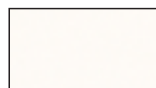

TG Off White

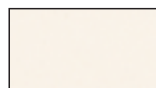

Dull White

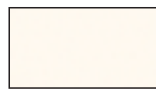

Museum Cream

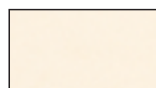

Warm Cream



Black

Black now with new Cotton+™ Alpha Cellulose top liner to ensure colour consistency. Further details available on our web site.



Timecare® Heritage Museum – CottonCore ‘Mammoth’

Made to the same high specification as the standard Timecare® Heritage Museum Board this ‘Mammoth’ oversize board is difficult to make, difficult to store, difficult to handle and difficult to deliver... but we aim to please.

Product code	Colour	Thickness mm	Sheet/1000kg	Size mm	Size inches	Pack qty
BDHCB0018	White	2.2	128	1630 x 2180	64 ³ / ₁₆ x 85 ¹³ / ₁₆	5

Timecare® Heritage Conservation – SolidCore

An economical alternative to cotton board, made from high-quality, chemically purified wood fibres. High in alpha cellulose and buffered with calcium carbonate, it resists airborne pollution thereby maintaining a neutral environment around the object. The paper is neutral-sized internally with AKD and externally with starch. It is laminated with EVA plasticiser-free adhesive which is more resistant to acid hydrolysis than other cheaper synthetic adhesives. This is important if you are looking for the maximum level of protection because, if the adhesive breaks down and ‘off-gasses’ (ie. acetic acid in the micro-environment of a frame or a box), the object enclosed will be damaged. The board may be easily cut and gives a smooth edge which will maintain its colour without yellowing throughout the life of the board. The board is suitable for ink and wash-line decoration because of the surface-sizing of the paper.

 **Linked Products:** Schimanek Heavy-Duty Guillotine p158; Mount Cutters p153; Framers Tape p153.

Specifications

- pH7.5 to 9
- High alpha cellulose content
- Chemically purified wood fibre
- Buffered (average 3%) calcium carbonate
- Internally and externally neutral-sized
- Lightfast, Blue Wool Scale reading of 5
- Passes Silver Tarnish Test (ASTM D2043)
- Passes Photographic Activity Test (PAT) (ISO 18916)
- Fine Art Trade Guild (FATG) Conservation Level
- Evacon-R™ EVA plasticiser-free laminating adhesive
- Natural pigments used fade and bleed-resistant



Applications

- Conservation mounting of prints, drawings and photographs
- Conservation framing
- Photographic storage and conservation
- Boxmaking and bookbinding
- Library conservation

Product code	Colour	Thickness mm	Sheets/1000kg	Size mm	Size inches	Pack qty
BDTHCA3401	White	0.5	2564	1120 x 815	44 ¹ / ₈ x 32 ¹ / ₁₆	25
BDTHCE3401	White	1.5	877	1120 x 815	44 ¹ / ₈ x 32 ¹ / ₁₆	5
BDTHCE6401	White	1.5	441	1630 x 1120	64 ³ / ₁₆ x 44 ¹ / ₈	5
BDTHCD3401	White	2.2	610	1120 x 815	44 ¹ / ₈ x 32 ¹ / ₁₆	5
BDTHCA3402	Cream	0.5	2564	1120 x 815	44 ¹ / ₈ x 32 ¹ / ₁₆	25
BDTHCE3402	Cream	1.5	877	1120 x 815	44 ¹ / ₈ x 32 ¹ / ₁₆	5
BDTHCE6402	Cream	1.5	441	1630 x 1120	64 ³ / ₁₆ x 44 ¹ / ₈	5
BDTHCD3402	Cream	2.2	610	1120 x 815	44 ¹ / ₈ x 32 ¹ / ₁₆	5
BDTHCA3403	Off White	0.5	2564	1120 x 815	44 ¹ / ₈ x 32 ¹ / ₁₆	25
BDTHCE3403	Off White	1.5	877	1120 x 815	44 ¹ / ₈ x 32 ¹ / ₁₆	5
BDTHCE6403	Off White	1.5	441	1630 x 1120	64 ³ / ₁₆ x 44 ¹ / ₈	5
BDTHCD3403	Off White	2.2	610	1120 x 815	44 ¹ / ₈ x 32 ¹ / ₁₆	5
BDTHCE3405	Silk	1.5	877	1120 x 815	44 ¹ / ₈ x 32 ¹ / ₁₆	5
BDTHCE3406	Satin	1.5	877	1120 x 815	44 ¹ / ₈ x 32 ¹ / ₁₆	5
BDTHCE3407	Sepia	1.5	877	1120 x 815	44 ¹ / ₈ x 32 ¹ / ₁₆	5
BDTHCE6407	Sepia	1.5	441	1630 x 1120	64 ³ / ₁₆ x 44 ¹ / ₈	5
BDTHCD3407	Sepia	2.2	610	1120 x 815	44 ¹ / ₈ x 32 ¹ / ₁₆	5



The Fine Art Trade Guild (FATG) is the trade association for the art and framing industry. The Guild develops and maintains internationally recognised standards including print standards, framing standards (five levels of framing), mountboard standards and guidelines for tapes and adhesives in framing.

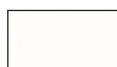

WHITE



Off White

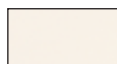

CREAM

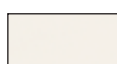

SILK

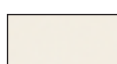

SATIN



SEPIA



The Kasemake-CXD machine can add names, description of contents or identification marks to board using the lightfast pigment ink pen and there is a variety of fonts to choose from. Using the special cutting tool we are able to provide customised mounts and linings for drawers and boxes. This example shows apertures in, and titles on, mountboard for Communion Tokens made to fit a Planorama® drawer.

Double-Face Conservation – ‘Mammoth’

Mounting and support board made from 100% chemically bleached pulp and laminated with a neutral pH adhesive, The paper has calcium carbonate alkaline reserve giving a minimum pH of 7.5. Double-sided in colour: one side Ivory the other side and core of the board being Bright Fluorescent White containing Optical Brightening Agents. Because of the OBAs it does not meet our standard for a full archival quality board. However, with this in mind it can be a very useful board for large-size mounting and presentation. Every effort is made to keep costs low but the large size can make packing and delivery more expensive than normal size boards and this should be taken into account when placing an order.

Product code	Thickness mm	Weight gsm	Size mm	Size inches	Pack qty
BDDSMB0001	1.5	1050	1250 x 1830	49 ¹ / ₂ x 72 ³ / ₄	5
BDDSMB0002	2	1480	1250 x 1830	49 ¹ / ₂ x 72 ³ / ₄	5

Unbuffered Conservation Board

A relatively low-density board made from non-fluorescent 100% chemically bleached pulp with a high alpha cellulose content. Neutral pH without the addition of an alkaline reserve. Synthetic laminating adhesive.

 **Linked Products:** Schimanek Heavy-Duty Guillotine p158; Mount Cutters p153; Framers Tape p153.

Applications

- Manufactured for mounting and archiving items preferring to be in contact with a non-alkaline board

Product code	Thickness mm	Weight gsm	Size mm	Size inches	Pack qty
BDARFB0001	0.5	300	1020 x 1520	40 x 59	10
BDARFB0002	1.5	960	1020 x 1520	40 x 59	5

Stouls 'Satin' Conservation - SolidCore

The boards in this range have a smooth satin surface, excellent rigidity, are easy to cut and are available in a choice of thicknesses to meet most needs. They are made from high-quality, chemically-purified wood fibres, high in alpha cellulose, buffered with calcium carbonate and laminated with EVA plasticiser-free adhesive. The board cuts cleanly and, because of the surface-sizing, it is suitable for ink and wash-line decoration.

Specifications

- pH7.5
- High alpha cellulose content
- Chemically purified wood fibre
- Buffered (average 3%) calcium carbonate
- Internally and externally neutral-sized
- OBA-free
- Lightfast, Blue Wool Scale reading of 5
- Passes Photographic Activity Test (PAT) (ISO 18916)
- Fine Art Trade Guild (FATG), conservation-level
- Evacon-R™ EVA plasticiser-free laminating adhesive
- Available in two shades: White and Off White and 6 thicknesses up to 3.8mm



Applications

- Conservation mounting of prints, drawings and photographs
- Conservation framing
- Photographic storage and conservation
- Boxmaking and bookbinding
- Library conservation

Product code	Colour	Thickness mm	Weight gsm	Size mm	Size inches	Pack qty
BDMUSA3101	White	0.60	400	800 x 1200	31 x 47	10
BDMUSA3901	White	0.60	400	1000 x 1400	39 x 55	10
BDMUSB3101	White	1.2	830	800 x 1200	31 x 47	5
BDMUSB3901	White	1.2	830	1000 x 1400	39 x 55	5
BDMUSC3101	White	1.9	1260	800 x 1200	31 x 47	5
BDMUSC3901	White	1.9	1260	1000 x 1400	39 x 55	5
BDMUSD3101	White	2.5	1700	800 x 1200	31 x 47	5
BDMUSD3901	White	2.5	1700	1000 x 1400	39 x 55	5
BDMUSE3101	White	3.2	2120	800 x 1200	31 x 47	5
BDMUSE3901	White	3.2	2120	1000 x 1400	39 x 55	5
BDMUSF3101	White	3.8	2570	800 x 1200	31 x 47	5
BDMUSF3901	White	3.8	2570	1000 x 1400	39 x 55	5
BDMUSA3102	Off White	0.60	400	800 x 1200	31 x 47	10
BDMUSA3902	Off White	0.60	400	1000 x 1400	39 x 55	10
BDMUSB3102	Off White	1.2	830	800 x 1200	31 x 47	5
BDMUSB3902	Off White	1.2	830	1000 x 1400	39 x 55	5
BDMUSC3102	Off White	1.9	1260	800 x 1200	31 x 47	5
BDMUSC3902	Off White	1.9	1260	1000 x 1400	39 x 55	5
BDMUSD3102	Off White	2.5	1700	800 x 1200	31 x 47	5
BDMUSD3902	Off White	2.5	1700	1000 x 1400	39 x 55	5
BDMUSE3102	Off White	3.2	2120	800 x 1200	31 x 47	5
BDMUSE3902	Off White	3.2	2120	1000 x 1400	39 x 55	5
BDMUSF3102	Off White	3.8	2570	800 x 1200	31 x 47	5
BDMUSF3902	Off White	3.8	2570	1000 x 1400	39 x 55	5
BDMUSA3402	Off White Special Size	0.60	400	850 x 1100	33 x 43	10
BDMUSB3302	Off White Special Size	1.20	830	840 x 1090	33 x 42	5
BDMUSC3302	Off White Special Size	1.90	1260	840 x 1090	33 x 42	5
BDMUSD3302	Off White Special Size	2.50	1700	840 x 1090	33 x 42	5
BDMUSE3302	Off White Special Size	3.20	2120	840 x 1090	33 x 42	5
BDMUSF3302	Off White Special Size	3.80	2570	840 x 1090	33 x 42	5

Stouls 'Van Gelder' Conservation – SolidCore

The boards in this range are similar in most ways to the Stouls 'Satin' conservation board except for the shades of White and Off White which are slightly different and it is stronger and a bit harder to cut. The boards are based on the well-known Van Gelder range of papers and have a smooth satin surface, excellent rigidity and are available in a choice of thicknesses to meet most needs. They are made from high-quality, chemically purified wood fibres, very high in alpha cellulose (98%), buffered with calcium carbonate, and laminated with EVA plasticiser-free adhesive. The board cuts cleanly and because of the surface-sizing it is suitable for ink and wash-line decoration.

Specifications

- pH7.5
- High alpha cellulose content 98%
- Chemically purified wood fibre
- Buffered (average 3%) calcium carbonate
- Internally and externally neutral-sized
- OBA-free
- Lightfast, Blue Wool Scale reading of 5
- Passes Photographic Activity Test (PAT) (ISO 18916)
- Fine Art Trade Guild (FATG), conservation-level
- Evacon-R™ EVA plasticiser-free laminating adhesive
- Available in two shades: White and Off White and 6 thicknesses



Applications

- Conservation mounting of prints, drawings and photographs
- Conservation framing
- Photographic storage and conservation
- Boxmaking and bookbinding
- Library conservation

Product code	Colour	Thickness mm	Weight gsm	Size mm	Size inches	Pack qty
BDVANA3101	White	0.60	400	800 x 1200	31 x 47	10
BDVANA3901	White	0.60	400	1000 x 1400	39 x 55	10
BDVANB3101	White	1.2	830	800 x 1200	31 x 47	5
BDVANB3901	White	1.2	830	1000 x 1400	39 x 55	5
BDVANC3101	White	1.9	1260	800 x 1200	31 x 47	5
BDVANC3901	White	1.9	1260	1000 x 1400	39 x 55	5
BDVAND3101	White	2.5	1700	800 x 1200	31 x 47	5
BDVAND3901	White	2.5	1700	1000 x 1400	39 x 55	5
BDVANE3901	White	3.2	2200	1000 x 1400	39 x 55	5
BDVANF3101	White	3.8	2600	800 x 1200	31 x 47	5
BDVANF3901	White	3.8	2600	1000 x 1400	39 x 55	5
BDVANA3102	Off White	0.60	400	800 x 1200	31 x 47	10
BDVANA3902	Off White	0.60	400	1000 x 1400	39 x 55	10
BDVANB3102	Off White	1.2	830	800 x 1200	31 x 47	5
BDVANB3902	Off White	1.2	830	1000 x 1400	39 x 55	5
BDVANC3102	Off White	1.9	1260	800 x 1200	31 x 47	5
BDVANC3902	Off White	1.9	1260	1000 x 1400	39 x 55	5
BDVAND3102	Off White	2.5	1700	800 x 1200	31 x 47	5
BDVAND3902	Off White	2.5	1700	1000 x 1400	39 x 55	5
BDVANE3902	Off White	3.2	2200	1000 x 1400	39 x 55	5
BDVANF3102	Off White	3.8	2600	800 x 1200	31 x 47	5
BDVANF3902	Off White	3.8	2600	1000 x 1400	39 x 55	5



© Photo : Christian Tchong

Artique Conservation – Solidcore and Surface Colour

'Artique' is a fine range of coloured, high alpha cellulose conservation mountboards from Larson Juhl, available in two thicknesses, 1.4mm and 2.8mm. The 2.8mm boards have the same colour at their core as their surface. The 1.4mm boards have a white core finished with a wide selection of coloured surface papers in neutral, bright and dark shades. Certain colours are available with a surface texture. 'Artique' complies with the Fine Art Trade Guild Conservation Level. This assures framers and consumers that their artwork will withstand the test of time and be well protected by the board.

Specification

- Made from chemically purified wood fibres, with a high alpha cellulose content
- Lignin-free. Kappa number less than 5
- Only natural fade and bleed-resistant pigments are used
- Blue Wool Scale reading minimum of 5
- Buffered with calcium carbonate (3-5% by weight)
- Passes the Silver Tarnish Test and Photographic Activity Test
- Plasticiser-free, calcium carbonate buffered PVA adhesive
- Chloride below 0.05%; Sulphate below 0.25%
- Accelerated Ageing Test - Tappi T.509 SU68:
 - Un-aged = pH8.9;
 - 100 yrs = pH8.9;
 - 200 yrs = pH8.9;
 - 300 yrs = pH8.9.
- Fully complies with FATG, conservation-level for mountboard

Product code	Colour	Thickness mm	Sheets/1000kg	Size mm	Size inches	Pack qty
BDLIAF3805	Cinnabar	1.4	1205	815 x 1020	40 x 30	5
BDLIAF3827	Ivy	1.4	1205	815 x 1020	40 x 30	5
BDLIAF3833	Graphite	1.4	1205	815 x 1020	40 x 30	5
BDLIAF3837	Birch	1.4	1205	815 x 1020	40 x 30	5
BDLIAF3852	Saffron	1.4	1205	815 x 1020	40 x 30	5
BDLIAF3854	Miro	1.4	1205	815 x 1020	40 x 30	5
BDLIAF3858	Raven	1.4	1205	815 x 1020	40 x 30	5
BDLIAF3861	Ivory Buff	1.4	1205	815 x 1020	40 x 30	5
BDLIAF3866	Everest	1.4	1205	815 x 1020	40 x 30	5
BDLIAF3875	Coal	1.4	1205	815 x 1020	40 x 30	5
BDLIAF3878	Lapis	1.4	1205	815 x 1020	40 x 30	5
BDLIAF3901	White	1.4	1205	815 x 1020	40 x 30	5
BDLIAF3902	Off White	1.4	1205	815 x 1020	40 x 30	5
BDLIAF3917	Linen	1.4	1205	815 x 1020	40 x 30	5
BDLIAF3918	Chalk	1.4	1205	815 x 1020	40 x 30	5
BDLIAF3934	Chestnut	1.4	1205	815 x 1020	40 x 30	5
BDLIAG3802*	Oyster	2.8	578	815 x 1020	40 x 30	5
BDLIAG3833*	Graphite	2.8	578	815 x 1020	40 x 30	5
BDLIAG3837*	Birch	2.8	578	815 x 1020	40 x 30	5
BDLIAG3858*	Raven	2.8	578	815 x 1020	40 x 30	5
BDLIAG3860*	Cotswold Grey	2.8	578	815 x 1020	40 x 30	5
BDLIAG3865*	Dover White	2.8	578	815 x 1020	40 x 30	5
BDLIAG3901*	White	2.8	578	815 x 1020	40 x 30	5
BDLIAG3934*	Chestnut	2.8	578	815 x 1020	40 x 30	5
BDLIAG3937*	Thatch	2.8	578	815 x 1020	40 x 30	5
BDLIAG3969*	Night	2.8	578	815 x 1020	40 x 30	5
BDLIAG3977*	Digital White	2.8	578	815 x 1020	40 x 30	5

*Please note: Larson Juhl Artique 2.8mm board is solid colour throughout



The colour reproduction of papers and boards in this catalogue is a guide only. Sample swatches are available for colour-matching purposes from CXD.



The colour reproduction of papers and boards in this catalogue is a guide only. Sample swatches are available for colour-matching purposes from CXD.



2.8mm SolidCore

1.4mm WhiteCore



Support Boards and Backing Boards

A Range of Frame Backing Boards

Conservation By Design offer a range of popular backing boards for a variety of uses and swatches are available free of charge.



BDARQA7302



BDARQA7303



BDARQA7304



BDARQA7305



BDARQA7306



BDARQA7307



BDARQA7308



BDARQA7309



BDARQA7310



BDARQA7311



BDARQA7312



BDARQA7313
Backing Board Swatch

ExpoCard™ Frame Backing Board

A sturdy puncture-resistant board suitable for backing boards within frames. It has a wood pulp centre which is laminated on both sides with a 325gsm, buffered, acid-free, chemically purified cellulose paper, pH7.5, Buff-coloured one side the other white.

Specifications

- Meets FATG Standard level

Product code	Thickness mm	Weight gsm	Size mm	Size inches	Pack qty
BDEXP00001	3.3	1920	1000 x 1400	39 3/8 x 55 1/8	5

Specifications

Neutralised chipboard with acid-free lining

- Meets FATG standard-level
- 90% recycled paper and board. pH7.0 to 8.0, PVA adhesive
- Suitable for backing and dry-mounting temporary items

Hardboard

- Meets FATG standard-level
- Suitable for backing only of temporary items

MDF - Smooth both sides

- Meets FATG standard-level
- Suitable for backing only of temporary items

Woodpulp Board

- Meets FATG standard-level
- 100% virgin pulp fibre. pH7.5 to 10.0
- Suitable for dry-mounting non-valuable temporary items

Fluted Kraft Lined Board

- Meets FATG standard-level
- Two-sided brown, 95% recycled paper and board fibre. pH7.0 to 5.0, starch adhesive. Meets FATG standard-level
- Suitable for backing only non-valuable items

Twin Wall Kraft

- Meets FATG standard-level
- 90% recycled paper and board. Water-based flute, starch adhesive

Aqua Conservation

- Meets FATG conservation-level
- 100% virgin sulphate board for the cover paper, 95% recycled paper and board for the core and PE brown 100% virgin kraft paper. Lignin-free, pH7.2 to 8.0 with a burst strength of 2200 KPA

White Core Conservation Board

- Meets FATG conservation-level
- High-quality alpha cellulose available in three thicknesses - 1100, 1600 and extra thick 4200 micron
- Acid and lignin-free, and bright white throughout. Buffered with calcium carbonate, making it the perfect low-cost choice for conservation artwork

Product code	Colour	Thickness mm	Sheets/ 1000kg	Size mm	Size inches	Pack qty
BDARQA7302	Neutralised chipboard with acid-free lining	White	2	1120 x 813	44 1/8 x 32	10
BDARQA7303	Hardboard	Brown	2	1218 x 913	48 x 36	50
BDARQA7304	MDF - smooth both sides	Brown	2	1218 x 913	48 x 36	50
BDARQA7305	MDF - smooth both sides	Brown	2.5	1218 x 913	48 x 36	50
BDARQA7306	Woodpulp board	Cream	1	1120 x 813	44 1/8 x 32	50
BDARQA7307	Fluted kraft lined corrugated	Brown	2.2	1120 x 813	44 1/8 x 32	50
BDARQA7308	Twin wall kraft - corrugated	Brown	2.5	1120 x 813	44 1/8 x 32	25
BDARQA7309	Aqua conservation - corrugated	Brown	2.2	1220 x 914	48 x 36	10
BDARQA7310	WhiteCore conservation backing board	White	1.1	1120 x 815	44 1/8 x 32 1/16	25
BDARQA7311	WhiteCore conservation backing board	White	1.6	1120 x 815	44 1/8 x 32 1/16	5
BDARQA7312	WhiteCore conservation backing board	White	4.2	1120 x 815	44 1/8 x 32 1/16	5
BDARQA7313	Backing Board swatch	-	-	-	-	-

Foilatack™ Moisture Barrier Foamboard

Lightweight panel with a laminated inert polystyrene core. Faced on two sides with a matt, white, coated 300gsm paper. The paper is lined on one side with an aluminium foil of 25 micron. The paper on the other side is covered with an acrylic, self-adhesive film under a peel-off silicone release paper. This adhesive layer allows the user to select and apply a material of choice. Foilatack™ makes an ideal conservation backing board for canvases or frames. Use the aluminium layer on the outside as a barrier against moisture coming from the wall. On the inner side of the frame use a material of choice applied to the pressure-sensitive adhesive. For example, a layer of Timecare® Conservation or 100% cotton Museum Board, possibly with Purification Paint™ applied to it to scavenger and purify the air within the enclosed frame. Alternatively apply a layer of Active Charcoal Cloth™, Corrosion Intercept® or RIBS Reactive Intercept® Barrier Foil to scavenge and purify the air.



Foilatack™ is light, easy-to-cut, moisture-proof and offers good puncture-resistance which can be improved by applying extra layers to the self-adhesive side. Using the self-adhesive layer, panels can be layered to produce thicker boards. If Foilatack™ is off-set using the adhesive layer boards can be overlapped to created larger size boards.

These boards can also be used for model-making, inkjet printing or as temporary exhibition panels for poster displays.

Product code	Size mm	Size inches	Thickness mm	Pack qty
FDFCOA0001	700 x 1000	27 ⁷ / ₁₆ x 39 ³ / ₁₆	5	25
FDFCOA0002	700 x 1000	27 ⁷ / ₁₆ x 39 ³ / ₁₆	10	10
FDFCOA0003*	700 x 1000	27 ⁷ / ₁₆ x 39 ³ / ₁₆	5	25
FDFCOA0004*	700 x 1000	27 ⁷ / ₁₆ x 39 ³ / ₁₆	10	10

* with one side adhesive

Premier Duo™ Foamboard

Acid-free, fully archival quality foamboard. Made with Grey and White Heritage Archival pHotokraft™ 230gsm paper liners laminated with EVA adhesive to a core of inert CFC polystyrene foam.

Specifications

- Colour: Duplex Grey/White
- Acid and lignin-free Heritage Archival pHotokraft™ paper
- Laminated with EVA adhesive
- 3.5mm, 5mm and 10mm thicknesses
- Polystyrene foam centre
- Clean, dust-free, easy-cutting

Applications

- Framing, display, model-making, boxmaking, artwork



Product code	Colour duplex	Thickness mm	Thickness mm	Size inches
BPDFGW1510	Grey/White	5	60 x 40	1524 x 1016 (Short Grain)
BPDFGW1076	Grey/White	5	30 x 40	762 x 1016 (Long Grain)

Standard Foamboard

Foamboard is a core of inert CFC polystyrene foam to which paper liners have been laminated on both sides to give a smooth, matt-coated surface. Foamboards are feather-light, warp-resistant and easy to cut. Acid-free papers and textiles can be laminated to the surface by either wet or dry-mounting techniques. Thicker and more rigid boards can be created easily by pasting together.

Specifications

- Colour: White
- Standard lining paper (not acid or lignin-free. Add a layer of archival paper from our range using Evacon-R™ adhesive to produce an acid-free surface)
- 3.5mm, 5mm and 10mm thicknesses
- Polystyrene foam centre
- Clean, dust-free, easy-cutting

Applications

- Framing, display, model-making, boxmaking

Callipers available

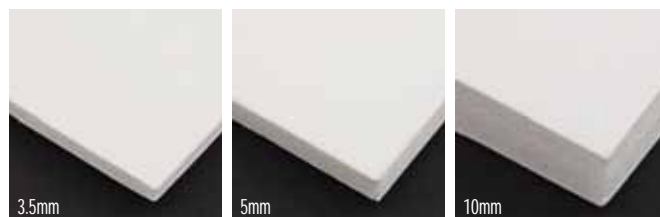

Product code	Colour	Thickness mm	Size mm	Size inches	Pack qty
FDFCOR3506	White	3.5	500 x 650	19 ¹ / ₁₆ x 25 ⁹ / ₃₂	25
FDFCOR3505	White	3.5	1000 x 1400	39 ³ / ₁₆ x 55 ¹ / ₁₆	25
FDFCOR3504	White	3.5	700 x 1000	27 ⁷ / ₁₆ x 39 ³ / ₁₆	25
FDFCOR0504	White	5	1000 x 1400	39 ³ / ₁₆ x 55 ¹ / ₁₆	25
FDFCOR0505	White	5	500 x 650	19 ¹ / ₁₆ x 25 ⁹ / ₃₂	25
FDFCOR0503	White	5	700 x 1000	27 ⁷ / ₁₆ x 39 ³ / ₁₆	25
FDFCOR1004	White	10	500 x 650	19 ¹ / ₁₆ x 25 ⁹ / ₃₂	10
FDFCOR1002	White	10	700 x 1000	27 ⁷ / ₁₆ x 39 ³ / ₁₆	10
FDFCOR1003	White	10	1220 x 2440	48 ¹ / ₃₂ x 96 ¹ / ₁₆	10
FSFCOR1001	White	10	1220 x 2440	48 ¹ / ₃₂ x 96 ¹ / ₁₆	10
FDFCOR1005	Black	10	1000 x 1400	39 ³ / ₁₆ x 55 ¹ / ₁₆	10

MSO Fasteners for Foamboards

Metal fasteners are essential for hanging foamboards (with polystyrene cores). Easy to use, requires no special instruments, tools: positioned manually.

Product code	Pack qty
SUMSOP0001	20
SUMSOP0002	200

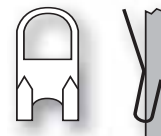

Timecare® Paper Honeycomb Panels

Lightweight, rigid panels with high compression strength. Acid-free, lignin-free paper with calcium carbonate alkaline reserve (3%), pH8, Neutral adhesive. Thickness 13mm. Colour: White. Cut with knives or saw using a fine-toothed blade.

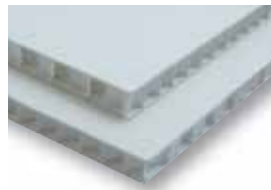

Specifications

- Acid and lignin-free paper core
- Acid and lignin-free surface papers
- Free from Optical Brightening Agents
- Buffered against acid-migration
- Archival standard adhesive
- High compression strength
- Colour: White

Applications

- Mounting works of art and textiles
- Freestanding display panels
- Construction large boxes eg; theatre models

Product code	Size mm	Size inches	Thickness mm	Pack qty
BDPHCB0001	1400 x 2500	55 ¹ / ₈ x 98 ³ / ₄	13	3

POLYNID™ Lightweight Polypropylene Honeycomb Board

A polypropylene honeycomb with 8mm hexagonal cells faced with polypropylene film, which is lined with non-woven, open-texture polyester material.

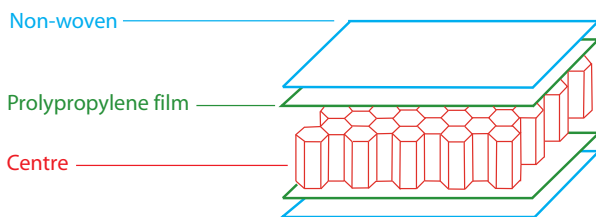

Product code	Size mm	Size inches	Thickness mm	Pack qty
BDPPHC0001	1200 x 2500	47 ¹ / ₄ x 98 ³ / ₄	15	6

Aluminium-Centred Honeycomb Board

Aluminium-Centred, honeycomb lightweight boards are rigid, strong, flat, ready-made honeycomb panels used extensively in the aircraft industry because of their extreme rigidity and strength.

There are two types - Aluminium-Centred Honeycomb Board 620 which have woven glass fibre reinforced epoxy skins and Aluminium-centred Honeycomb Board 220, which have aluminium skins. Boards can be bonded to form even larger sheets.



Specifications

- Aluminium honeycomb of 83kg/m³ (5.4lb/ft³) nominal density

Applications

- Ideal support for heavy items such as mosaics and large textiles
- Linings and backings for paintings and showcase

Product code	Outer skin	Thickness mm	Size mm	Size inches	Pack qty
BDHEXA1224	Aluminium	12.7	1250 x 2500	49 ³ / ₁₆ x 98 ⁷ / ₁₆	1
BDHEXG0264	Glass Fibre	25.4	2440 x 1220	96 ¹ / ₁₆ x 48 ¹ / ₁₆	1
BDHEXG1224	Glass Fibre	12.9	2440 x 1220	96 ¹ / ₁₆ x 48 ¹ / ₁₆	1

Gatorfoam®

Gatorfoam® is an extremely rigid, lightweight composite display board which combines excellent strength-to-weight values and versatility with archival quality which allows its use for display-mounting of museum artefacts and materials requiring a non-acidic environment. Resin-impregnated, chemically purified wood pulp boards are bonded to both sides of a high-density, smooth-cutting polystyrene core.



The smooth-finish board accepts screen printing, acrylic and oil paint, and is sufficiently water-resistant to withstand exterior use. Uniform density allows cutting by hand and power tools, use of screw or wire fixings, and a variety of adhesives and laminating fabrics. When mounting acid-intolerant material for prolonged display it is advisable to laminate the mounting surface of Gatorfoam® with an alkaline paper or board.

Specifications

- Covering: bleached wood pulp
- Core: dense extruded polystyrene foam
- pH5.5 to 6.5
- Out-gassing: material in parts per 100mm only
- Combustibility: avoid exposure to open flame, can be coated with fire-retardant paint
- UV-resistance: Exposed polystyrene core should be painted with a water-based coating if subjected to prolonged exposure to UV light



Applications

- Lightweight mounting
- Display panels, signage, models and other fabrication

Product code	Colour	Thickness mm	Size mm	Size inches	Pack qty
BDGATO0001	White	5	1218 x 2438	47 ¹⁵ / ₁₆ x 96	1
BDGATO0002	White	10	1218 x 2438	47 ¹⁵ / ₁₆ x 96	1

Please note these products may incur additional charges for handling

Ethafoam®

Ethafoam® is a resilient and flexible closed-cell polyethylene foam which can handle repeated shocks and impacts. Ethafoam® can be cut or machined to precise shapes for the protection of fragile objects during storage or shipping. It is resilient and holds its shape even under heavy load. It has excellent chemical resistance, low water-absorption and water-vapour transmission, good insulation value, no odour and is easily fabricated.

 **Linked products:** Thermocutter ZTS20 p161, and CXD Hot Knife p161, Kasemake CXD p175-176.



Product code	Size mm	Size inches	Thickness mm	Pack qty
BDETHA0100	1000 x 50	39 ³ / ₈ x 164ft ¹ / ₂	2	Roll
BDETHA0010	600 x 900	23 ³ / ₈ x 35 ³ / ₈	10	3
BDETHA0050	600 x 900	23 ³ / ₈ x 35 ³ / ₈	50	3
BDETHA0002	600 x 900	23 ³ / ₈ x 35 ³ / ₈	100	1

Vivak® PETG Plastic Sheet

Transparent, thermoplastic sheet up to 3mm thick, offering superior impact strength over acrylic and cost-effectiveness compared to polycarbonate. It can be cut, punched and folded without sacrificing structural integrity. It can be bonded or fastened with adhesives, ultrasonic welding or rivets. Vivak® PETG sheets are suitable for a variety of conservation storage and display applications including framing, transparent box tops, thermoformed collection trays, the production of object mounts and book cradles. It can be heated to form complex shapes and tight bends but has the advantage that it can be manipulated cold to create simple bends and curves for the production of custom exhibition mounts or book cradles.



Vivak® can be painted, silk screen printed or hot-stamped. Shapes can be cut with blades, mills, routers or laser cutters. The cut edges can be flame-polished to produce a perfect finish. Vivak® sheets are supplied with solvent-free PE sheets to protect the surface against damage during transport or fabrication.

Product code	Size mm	Thickness mm	Pack qty
PAPETG7501	2050 x 1250	750	10
PAPETG7502	1200 x 800	750	5
PAPETG7503	800 x 600	750	5

Plastazote® Foam

Cross-Linked, Closed-Cell Polyethylene Nitrogen Expanded Foam. Tests show Plastazote® foam to be stable, safe and non-reactive when in contact with a variety of museum objects. Plastazote® LD45 is most commonly used in the storage of museum objects, but is only one grade in a wide range of nitrogen-expanded foams.

Plastazote®, Evazote and Supazote foams are physically blown foams. They are the only products of their type which are expanded using pure nitrogen gas. This results in pure, chemically inert foams, with excellent physical properties.

Foams made using solid chemical blowing agent systems always contain a significant amount of blowing agent chemical residues which can detract from the physical, chemical and biological properties of the foamed polymer. Foams manufactured using volatile liquids can suffer from dimensional changes. Plastazote®, Evazote and Supazote foams contain no blowing agent residues.

 *Linked products: Thermocutter ZTS20 p161, and CXD Hot Knife p161, Kasemake CXD p175-176.*

Specifications

- Tolerance: For all dims. to comply with DIN 7715
- Meets UK-military specification DEF STA N 81-116
- This standard states that the water-soluble sulphate content, calculated as Na2SO4 to the requirements of BS2782 method 452E, shall be less than 0.1%/mm

Applications

- Storage and packing of fragile items
- Boxmaking
- Backing and support panels
- Drawer and box-liners
- Customised packaging
- Picture framing

Foam Sheet - LD45

Product code	Colour	Thickness inches	Size mm	Size inches	Pack qty
BDPLA_0003	Grey/White/Black*	3	1500 x 1000	59 1/16 x 39 3/8	10
BDPLA_0005	Grey/White/Black*	5	1500 x 1000	59 1/16 x 39 3/8	6
BDPLA_0009	Grey/White/Black*	9	1500 x 1000	59 1/16 x 39 3/8	3
BDPLA_0012	Grey/White/Black*	12	1500 x 1000	59 1/16 x 39 3/8	5
BDPLA_0015	Grey/White/Black*	15	1500 x 1000	59 1/16 x 39 3/8	2
BDPLA_0030	Grey/White/Black*	30	1500 x 1000	59 1/16 x 39 3/8	1

*Grey Plastazote® available in any quantity, Black and White in pack quantity only.

Timecare® Channel Panel™

Formed from 20mm thick LD45 Plastazote® that has channels which are 3mm wide x 5mm deep, running across the width of the sheet. Each channel is spaced 5mm apart.



For full specifications see Plastazote® (left and below). Special sizes made to order.

Applications

- Dividing drawers
- Lining boxes (ie. glass plate negative storage)
- Making deep boxframes



Product code	Colour	Thickness inches	Size mm	Size inches	Pack qty
BDFPCG7226	Grey	20	2000 x 1000	78 3/4 x 39 3/8	1



Plastazote® of various thickness glued to mountboard, for use as insert spacers for specialist framing

Cross section of frame with Plastazote® behind stretched linen

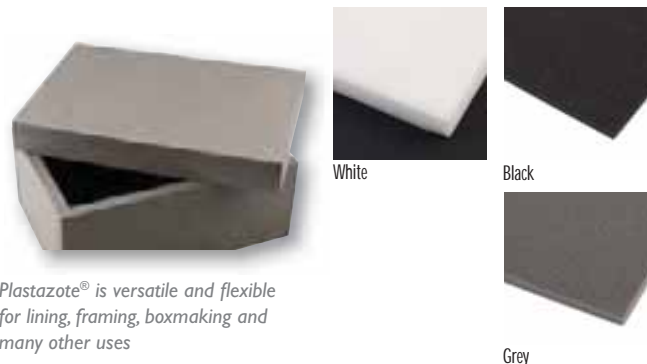

Plastazote® is versatile and flexible for lining, framing, boxmaking and many other uses





Equipment and Accessories

Equipment and Accessories

Conservation Accessories and Tools
Adhesives, Pastes and Consolidants
Tapes
Labelling
Pens, Pencils and Inks
Book Support and Display
Hanging Systems
Clarity and Tru Vue® Glass and Acrylic
Cutting Equipment
Repair and Conservation
Alan Buchanan Equipment
Heat-Sealing and Welding Machines
Ultrasonic welding
Box-Measuring and Making
Pest Management
Oxygen-Free Storage and Treatments
Disaster Response, Recovery and Prevention Products
Humidity Control
Testing Indicators
Environmental Monitoring
Air Purifiers
Polish and Dressings
Conservation Cleaning
Chemicals, Solvents and Cleaning Fluids
De-acidification Solutions and Equipment
Protection Equipment and Accessories
Brushes
Lighting Equipment
Cold Storage
Books and DVDs on Conservation and Preservation

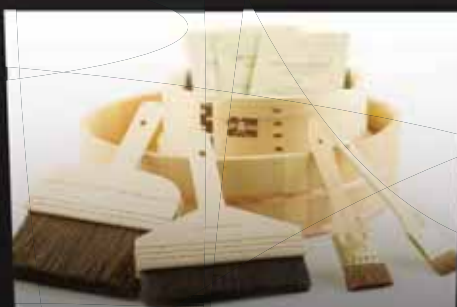

Conservation Accessories and Tools

The Conservation By Design (CXD) range of equipment has been developed to provide a 'one stop shop' for all conservation and restoration needs. Since conservators have been involved in the development process, product functionality and ease of use are particular features of the range. Most items are available for sale, but some can be hired to avoid the need for capital expenditure.

This range of products includes equipment to perform most of the tasks required by a conservator such as vacuum treatments, book-cleaning, polyester-welding, board-cutting and creasing, mount-making, boxmaking, vacuum-packing and many more. Included in the range is specialist equipment for Libraries, Archives, Museums, Historic Houses and Galleries, ranging from large mobile automatic book-cleaners to brushes and erasers. Items of particular interest are the CXD Cold Storage system, Planolux™ light walls, and the KnoOx™ measurement devices for oxygen in sealed packages – a vital piece of equipment for all conservators creating anoxic storage and packaging.

Micro-Mesh®

Micro-Mesh® cushioned, abrasive-buffer files are part of the unique Micro-Mesh® abrasive-polishing system. Extremely fine abrasive particles are mounted on foam and will not flake away like most abrasives sheets. Micro-Mesh® buffer files are 145mm long and made of a plastic core covered on each side with a foam-coating with different levels of highly effective abrasives, differentiated by colour.



They are rigid but have a degree of flexibility, useful for delicate work. Micro-Mesh® files can be washed in water allowing them to be used many times.

Applications

Applications: Polishing numerous materials such as metal, plastic, bone, wood, leather etc.

Product code	Description	Size mm	Size inches	Grade
SUATMM0002	A 2-way buffer	145 x 15	5 ⁷ / ₆₄ x 1 ¹ / ₂	Black - 100, Dark Grey - 150
SUATMM0003	B 3-way buffer	145 x 12	5 ⁷ / ₆₄ x 1 ¹ / ₂	Pink - 2400, White - 4000, Grey - 12000
SUATMM0004	C 4-way buffer	145 x 12	5 ⁷ / ₆₄ x 1 ¹ / ₂	Black - 180, Pink - 2400, White - 4000, Grey - 12000

 *Linked Products: Pre-Lim surface cleaner p208 and Renaissance Wax on p208.*

Goldfinger Metallic Paste

Gold and Silver paste in a tube. Rowney Goldfinger is a handy product for small fillings and repairs of gilt frames, antiques and other objects. Apply with a cloth, cotton bud or finger on wood, clay, plaster, gesso, leather, cloth, paper etc. It can be diluted with white spirit or turpentine and applied with a brush for fine work. When dry, Goldfinger can be buffed to a fine lustre with a soft cloth. To preserve the lustre it can be treated with varnish.



Supplied in 22ml tubes. Available in 5 colours.

Product code	Colours
SUATGP0001	Copper
SUATGP0002	Antique Gold
SUATGP0003	Sovereign Gold
SUATGP0004	Green Gold
SUATGP0005	Silver

Conservators' Choice Artist Quality Watercolours

Top-of-the-range watercolours from Daler-Rowney selected to meet the most common requirements of paper conservators. They are made from the finest pigments offering the greatest possible transparency and light-fastness. Their fine performance is achieved by a precise formulation based on an aqueous solution of gum Arabic containing a suspension of pigments selected for their purity.



24 half-pan colours in a black and white, baked-enamel metal box with integral mixing palettes.

Product code	Description
SUATWC0001	Box of 24 colours

Riveting Machine and Matrices

A small, robust machine for fast riveting.



Product code	Description
EQHRJR1000	Rivet Junior
EQHRJR1001	Matrix for Rivet Junior
EQHRWP0150	Hand machine for attaching

Riveting Punch

Cylindrical metal hammer punch with one concave end and one domed end (dia. 7mm - length 45mm) for hammer-fixing rivets. A simple but effective tool useful for boxmaking and framing.



Product code	Description
EQRIHE0070	For use with hammer

Two-Part Compression Rivet

For boxmaking and fixing label-holders, buckles and various attachments.



Product code	Description
EQRIVT2530	For 2.5 - 3.0mm Board
EQRIVT3040	For 3.0 - 4.0mm Board

Linked Products: CXD Japanese Screw Punch p153.

Two-Part Cap Rivets

Two-part steel with nickel (silver) finish rivets. 7mm shank depth x 10mm base. Fits through a 4mm diameter drilled or punched hole. Domed top. Can be fastened by simply pressing or tapping with a small hammer or mallet. Used for mounting, folder/box production. Suitable for board thickness from 2 to 7mm.



Product code	Description	Pack qty
SUPROD0008	Two-part Cap Rivet	100

Linked Products: CXD Japanese Screw Punch p153.

Polyethylene Washers

White polyethylene washer used for attaching string or fasteners for folder/box production. Attach using rivets or other fastenings.



Product code	Description	Diameter	Thickness	Central hole	Size inches	Pack qty
SUPPBW7344	White washer	19mm	2mm	4mm	3/4 x 5/4 x 7/32	100

CXD Superior Millboard™ and Premier™ Boxboard washers also available

Brass-Plated Washer

16mm diameter brass-plated washer.



Product code	Description	Pack qty
EQBPWA0017	Brass-plated washer - 16mm diameter	250

Linked Products: CXD Japanese Screw Punch p153.

Round-Head Nails

- Brass-plated steel 12 x 8

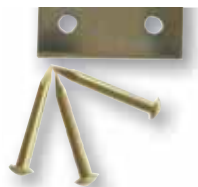

Product code	Description
EQRHWI0030	Triangular Loops - pack of 200 gram

Heavy BeanBag™ Paperweights

Malleable paperweights utilising lead shot sealed in a polyethylene inner bag covered with a removable outer fabric bag, allowing it to be washed when required or to use the waterproof inner bag for wet treatments.



Applications

Holding documents safely in position during mounting of graphic documents, photography or for aqueous conservation work.

Product code	Weight g	Size mm	Size inches
EOPAW0100	200	55 x 100	2 1/4 x 3 5/8
EOPAW0140	450	55 x 140	2 1/4 x 5 3/8
EOPAW0255	900	55 x 255	2 1/4 x 10 1/4

Fountain Brush™

This handy tool works like a fountain pen but uses a white, synthetic bristle brush instead of a nib. It has a flexible polypropylene plastic handle which acts as a reservoir.



Simply unscrew and fill it with water or other suitable solvent-free liquid such as a preparation of Tylose or highly diluted Klucel. The Fountain Brush™ is ideal for wet-cutting Japanese paper or delicate and precise consolidation work.

Product code	Description
EQBRUS0140	Fountain Brush™



Plastic Syringes

Measuring syringes for application of adhesives, resins and other viscous liquids. The syringe's translucent body shows the level of product. Different flexible or rigid end-pieces are available.



Product code	Description
SUATPS0001	A Kit with 2 syringes and 6 end-pieces
SUATPS0002	B Pack of 10 rigid-tip end-pieces
SUATPS0003	C Pack of 10 plastic flexible fine end-pieces
SUATPS0004	D Pack of 10 medium rigid-tip end-pieces
SUATPS0005	Pack of 10 x 3cm conical-tip end-pieces
SUATPS0006	Pack of 10 x 4cm plastic end-pieces

Bone Folders

A range of high-quality, genuine bone folders, excellent for making precise creases or folds in papers, tapes or board. Very handy for putting together die-cut boxes and folders.



Product code	Size mm	Size Inches
SUBBFL0005	100	3 ¹⁵ / ₁₆
SUBBFL0003	152	5 ⁴³ / ₆₄
SUBBFL0006	160	6 ¹⁹ / ₆₄
SUBBFL0007	170	6 ¹¹ / ₁₆
SUBBFL0008	200	7 ⁷ / ₈
SUBBFL0004	232	9 ⁹ / ₆₄

Teflon® 'Bone' Folders

These virtually unbreakable 'bone' folders are made from Teflon® and are inert to almost every known chemical and combine the same non-stick properties associated with other Teflon® products.



Product code	Description	Size mm	Size inches	Pack qty
SUTBFL0002	A 1 pointed and 1 chisel-end	150 x 20 x 6	5 ⁹ / ₃₂ x 2 ¹ / ₃₂ x 1 ¹⁵ / ₆₄	
SUTBFL0007	B Both chisel-ends	55 x 83 x 8	2 ¹ / ₆₄ x 3 ¹ / ₆₄ x 3 ¹ / ₁₆	
SUTBFL0008	C 1 pointed and 1 chisel-end	145 x 20 x 10	5 ⁵ / ₆₄ x 2 ¹ / ₃₂ x 2 ⁵ / ₆₄	
SUTBFL0003	D 1 pointed and 1 rounded-end	130 x 17 x 7	5 ¹ / ₈ x 4 ³ / ₆₄ x 7 ¹ / ₃₂	
SUTBFL0009	E 1 pointed and 1 chisel-end	150 x 10 x 10	5 ⁹ / ₃₂ x 2 ⁵ / ₆₄ x 2 ⁵ / ₆₄	
SUTBFL0010	F 1 rounded and 1 chisel-end	190 x 30 x 3	7 ³ / ₃₂ x 1 ¹ / ₁₆ x 1 ¹ / ₈	
SUTBFL0011	G 1 curved and 1 chisel-end	185 x 23 x 3	7 ¹ / ₃₂ x 2 ¹ / ₃₂ x 1 ¹ / ₈	
SUTBFL0001	H 1 pear-shaped and 1 chisel-end	185 x 23 x 3	7 ¹ / ₃₂ x 2 ¹ / ₃₂ x 1 ¹ / ₈	
SUTBFL0004	I 1 chisel pointed and 1 chisel-end	185 x 23 x 3	7 ¹ / ₃₂ x 2 ¹ / ₃₂ x 1 ¹ / ₈	
SUTBFL0005	J 1 chisel pointed and 1 rounded-end	180 x 12 x 3	7 ¹ / ₃₂ x 1 ¹ / ₃₂ x 1 ¹ / ₈	
SUTBFL0006	K 1 chisel pointed and 1 rounded-end	500 x 30 x 5	19 ¹ / ₁₆ x 1 ¹ / ₁₆ x 1 ¹ / ₆₄	

Wood 'Bone' Folders

Hardwood folders for when only wood will do.



Product code	Description	Size mm	Size inches	Pack qty
SUWBFL0001	Wood	25	4 ³ / ₆₄	1

Stainless Steel Spatulas

A range of double-ended polished stainless steel spatulas. Selected for conservation and binding work.



Product code	Description	Length mm	Length inches
EQSPAT0001	A 1 rounded and 1 screwdriver-end	150	5 ⁹ / ₃₂
EQSPAT0003	B 1 conical and 1 screwdriver-end	155	6 ¹ / ₆₄
EQSPAT0003	C 1 rounded and 1 pointed-end	155	6 ¹ / ₆₄
EQSPAT0006	D 1 chisel rounded and 1 screwdriver-end	200	7 ⁷ / ₈
EQSPAT0005	E 1 rounded and 1 screwdriver-end	210	8 ¹ / ₆₄
EQSPAT0007	F Spoon 25 x 12mm	210	8 ¹ / ₆₄
EQSPAT0008	G Spoon 25 x 18mm	235	9 ¹ / ₄
EQSPAT0004	H 1 rounded and 1 screwdriver-end	195	4 ³ / ₆₄

Solvent Bottles

Squeeze bottles in high-density, translucent polyethylene. A slight pressure on the bottle releases the solvent. The system closes as soon as released.



Product code	Capacity
EQSOLV0100	Translucent polyethylene. 100cc
EQSOLV0180	Translucent polyethylene. 180cc
EQSOLV0240	Translucent polyethylene. 240cc

7-Cell Porcelain Palette

'Margarite-shaped' porcelain palette. 140mm diameter with 7 mixing cells.



Product code	Description	Diam. mm	Diam. inches
EQPALE0140	7-cell porcelain palette	7 Cells 140	5 ³ / ₆₄

Porcelain Saucer Set with Cover

A set of 5 stackable, 90-diameter mixing saucers with a top cover to prevent evaporation.



Product code	Description	Diam. mm	Diam. inches
EQSAUC0005	Porcelain saucer set with cover	90	3 ³ / ₆₄

Plastic Saucer Set with Cover

A nest of 5 plastic mixing saucers with a top cover for the largest one.



Product code	Description
EQNEST0005	Set of 5 nestable saucers with cover

Plastic Tweezers

Polypropylene or Polyamide tweezers in 3 tip styles.

Type A: 100% polypropylene (180° maximum) can be sterilised.

Types B and C: Glass-fibre-reinforced antistatic polyamide, resistant to acids and temperatures up to 200°C.



Product code		Description	Length mm	Length inches
EQTWEE0001	C	Straight tip	125	4 ⁹ / ₆₄
EQTWEE0002	A	Blunt tip	120	4 ⁷ / ₃₂
EQTWEE0003	B	Hook tip	120	4 ⁷ / ₃₂

Stainless Steel Tweezers

A 4-model range of straight or curved tweezers in different sizes.

Model A. Straight pointed. Satin-finish, stainless steel with Teflon® coated jaws.

Models B. Curved point.

Chrome-plated stainless steel.

Models C and D. Straight pointed. Chrome-plated stainless steel.



Product code		Description	Length mm	Length inches
EQTWEE0012	B	Curved/Pointed	155	6 ¹ / ₆₄
EQTWEE0011	A	Pointed ends	160	6 ³ / ₆₄
EQTWEE0014	D	Curved/Pointed	75	2 ⁸ / ₆₄
EQTWEE0013	C	Teflon Coated Tips	120	4 ⁷ / ₃₂

White Polyethylene Washing Trays

Quality, high-density polyethylene washing tray in 4 sizes.

Non-ribbed, flat-bottom style.

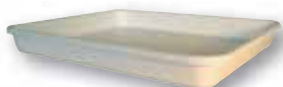

Product code	Length mm	Length inches	Colour
EQTRAY0001	601 x 508 x 89	11 ⁷ / ₃₂ x 20 x 3 ¹ / ₂	White
EQTRAY0002	712 x 610 x 89	4 ¹ / ₃₂ x 24 ¹ / ₆₄ x 3 ¹ / ₂	White
EQTRAY0003	826 x 705 x 108	32 ² / ₆₄ x 27 ³ / ₄ x 4 ¹ / ₄	White
EQTRAY0004	120 x 946 x 108	4 ² / ₃₂ x 37 ¹ / ₄ x 4 ¹ / ₄	White

Grey PVC Washing Trays

Medium-grey colour PVC washing tray in 4 sizes. Flat-bottom style with no ribbing, rounded edges.



Product code	Size mm	Size inches	Thickness	Colour
EQTRAY3040	300 x 400 x 90	11 ³ / ₁₆ x 15 ¹ / ₄ x 3 ³ / ₆₄	2	Grey
EQTRAY4050	400 x 500 x 90	15 ¹ / ₄ x 19 ¹ / ₁₆ x 3 ³ / ₆₄	2	Grey
EQTRAY5060	500 x 600 x 90	19 ¹ / ₁₆ x 23 ³ / ₈ x 3 ³ / ₆₄	2	Grey
EQTRAY6080	600 x 800 x 90	23 ³ / ₈ x 31 ¹ / ₂ x 3 ³ / ₆₄	3	Grey

Hand Pump Spray Bottle

A reusable, hand-pressurised, polypropylene spray bottle. One manual pressurisation permits spraying up to 100ml. The bottle is translucent to provide a visible volume check.

Can be used to apply a fine mist of water, cleaning solution or methylcellulose sizing. Good resistance against chemical agents.

NOTE: not intended for use with solvents.



Product code	Description
EOSPRA0001	Spray bottle 200ml

Trigger-Spray Bottle

High-density polyethylene bottle, fitted with a spray trigger with a superfine adjustable nozzle, and fitted with a ball avoiding the draining of the pump. Screw adaptation-ring. Translucent white 750cl bottle marked every 100cl. High-performance, adjustable, refillable.



Product code	Description	Size
EOSPRA0002	Bottle with spray trigger	750ml

Eco-Spray Micro-Diffuser

Micro-spray specially designed for products requiring perfect spraying quality in terms of finesse, distribution and regularity of the particles. The Eco-Spray pressure tank is a small, one-piece, aluminium container able to withstand an internal pressure of 18 bars. The propellant is non-flammable, non-explosive, non-toxic and odourless. An empty bottle (contents 125ml) made of high-density transparent polyethylene (PEHD) with a screw capsule offered as an option, you can fill it with the liquid you need for your work. Without this bottle, liquids can be taken from any source. Rechargeable: simply change the pressure tank and/or the product recipient. You can spray water, oil or alcohol-based liquids, as required.

Autonomous: Eco-Spray is totally independent. No wires, no motor, it gives you a very long working time and the possibility of spraying thousands of times: 440ml with a single pressure tank.



Applications

Micro-spraying in the treatment of papers, preventive or curative treatment of documents. To be used as necessary to micro-spray water, oil or alcohol-based products.

Product code	Description
EOSPRA0011	Aluminium container tank
EOSPRA0012	Eco-spray micro-diffuser
EOSPRA0013	Empty bottle 125ml
EOSPRA0014	Set of 3 jets

Adhesives, Pastes and Consolidants

Evacon-R™ Conservation Adhesive

A specially formulated neutral pH, non-plasticised, reversible archival paper-laminating adhesive.

The adhesive was originally specified by the founder of CXD, Stuart Welch, and designed by a leading adhesive chemist for laminating Timecare® Heritage Museum Boards, Conservation Boards and Premier Duo™ Archival Die-cut Boxes and Envelopes.

In 1983 there was no laminating adhesive which took into account questions of pH, plasticisers, fungicides and acid hydrolysis. With the guidance of the late Fred Marsh and in conjunction with the adhesive chemist, it was decided that an EVA-type adhesive best fulfilled the requirements of conservation with the practicalities of laminating.

The adhesive is designed to be as safe as possible for all kinds of storage uses including photographs. It has passed the Silver Tarnish Test and PAT test and is less susceptible to acid hydrolysis than the more common PVA adhesives, which can break down and emit acetic acid vapours. These vapours can be particularly harmful to boxed items trapped in a microclimate. The resistance to hydrolysis of the Evacon-R™ is probably because of the random blocks of ethylene, which affect the stereochemistry of the system.

The incorporation of a small quantity of calcium carbonate also helps to stabilise the system.



Specifications

- Water-soluble
- Non-plasticised
- pH7.5
- Ethylene Vinylacetate Copolymer Emulsion
- Passes Photographic Activity Test (PAT) (ISO 18916)



Applications

- Suitable for laminating papers and boards, boxmaking, envelopes and general bookbinding work

Product code	Description	Weight	Pack qty
SUEVAR0001	Bottle	125g	1
SUEVAR0002	Bottle	1kg	1
SUEVAR0003	Jerry can	5kg	1
SUEVAR0004	Jerry can	10kg	1
SUEVAR0005	Jerry can	25kg	1

Texicryl™ Acrylic Emulsion

Texicryl™ is an all acrylic pH9 to 9.5 copolymer which is most commonly used in conservation as a heat-sensitive adhesive for coating fine tissue. Other uses include textile conservation, framing and mounting. It is a white liquid acrylic emulsion with a heat activation temperature around 70° C. Reversible in I.M.S. and I.M.S. & water. Solid content 55%; Viscosity@ 25°C 1.0-2.5 poise; minimum film-forming temperature of 6°C.

Specifications

- Acrylic pH9 to 9.5 copolymer
- Solid content 55%; viscosity @ 25°C 1.0-2.5 poise; minimum film-forming temperature of 6°C (ISO 18916)

Applications

- Coating fine tissue and material substrates
- Production of wood primers
- Binder for fabric backings

Product code	Description	Capacity	Pack qty
SUTEXA0002	Acrylic adhesive	1kg	1

Primal (Rhoplex) Acrylic Dispersion (WS24 and B60A)

An acrylic colloidal dispersion supplied in water. Primal WS24 has a much finer particle size than PVA emulsions, approximately 0.03 microns. Primal WS24 is especially good for the consolidation of dry bone and material from archaeological sites. It is also a popular choice in the consolidation of plaster, wall paintings and, because of the very fine particle size, has also been found useful for many different consolidation problems.



Because Primal WS24 is alkali-soluble it should not be used for exterior treatments. Primal B60A has been developed specifically for this purpose, technical details are available on request.

Specifications (WS24 only)

- This product is stabilised by polar groups and does not require the addition of emulsifiers or stabilisers
- Appearance: milky white liquid
- Odour characteristic: Ammonia odour
- Solids content: 36%
- pH7
- Viscosity: 600 CPS maximum
- Weight: 4.07kg (8.9lbs) per 4.546l litres (1 gallon)
- Glass transition temperature: 39°C

Product code	Description	Capacity ltr
SUPRIM0001	WS24	1
SUPRIM0002	B60A	1

Beva® 371

A heat-seal adhesive developed which is widely used for the lining of oil paintings, heat-seal facings and the making of laminates with fibreglass etc. It is applied cold and causes no contractions, expansion or softening of the materials to which it is applied making its application possible on even the most delicate surfaces. Shrinking and distortion is minimal and heat-sealing can be done days or weeks after application.



Beva® 371 is reversible and errors can be easily corrected even after heat-sealing. It is easy to remove and can be remelted whenever needed. Beva® 371 can be applied by brush, paint roller or spray without impregnation of solvents.

Hot Press p171; Tacking Irons p161.

Specifications

- Non-aqueous
- Dissolved in non-polar petroleum fractions (Please note this product can be exported)
- Activation temperature of 65-70°C
- Easy to remove
- Re-meltable
- Low viscosity

Applications

- Widely used for the lining of oil paintings, heat-seal facings and the making of laminates with fibreglass etc.

Product code	Description	Size mm	Size inches	Capacity	Pack qty
SUBEVA0371	Heat-Set Adhesive Film	690 x 10m	27 ¹ / ₄ x 32ft 9 ⁵ / ₁₆		1
SUBEVA1371	Heat-Set Adhesive Film	690 x 1m	27 ¹ / ₄ x 39 ³ / ₈		1
SUBEVA3711	Adhesive			1 litre	1
SUBEVA3715	Adhesive			5 litre	1

Archival Aids Conservation Adhesive

Conservation Adhesive is a solution of Paraloid B72 in acetone made in accordance with Stephen Knobb's original formulation published in 'Studies in Conservation' Vol 31, Feb. 1986 pp. 7-14. Suitable for glass, ceramics etc.



Product code	Description	Capacity	Pack qty
SUCONA0020	Conservation adhesive	150ml bottle	1

Paraloid B72

Paraloid B72 is an adhesive for repairs to pottery, wood, metal, ivory, glass and all porous surfaces except rubber. Paraloid B72 is virtually colourless and tends to resist yellowing for a considerable length of time. Glass transition temperature of approximately 40°C. Not having instant grab, fragments can be easily readjusted and surplus adhesive removed with acetone, thereby making any joint virtually invisible. Slower drying time than ADI makes B72 the popular choice for archaeological material on and off-site.

Copolymer of methyl acrylate and ethyl methacrylate.

Soluble in : N-butanol, diacetone alcohol, methylene chloride, ethylene dichloride, trichloroethylene alcohol, ethyl acetate, amyl acetate, toluene, xylene, acetone, 2-ethoxyethanol, methyl ethyl ketone and dimethyl formamide.

Specifications

- Virtually colourless and tends to resist yellowing
- Glass transition temperature of approximately 40°C
- Fragments can be easily readjusted
- Surplus adhesive removed with acetone



Applications

- For repairs to pottery, wood, metal, ivory, glass and all porous surfaces except rubber
- SUPARA 0072 for applying reference-marking

Product code	Description	Weight kg	Capacity ml	Pack qty
SUPARA0072	Fixative Pre-diluted		125	1
SUPARA7072	Granules	1		1
SUPARA7210	Tube HMG		14	1



Microballoons

Microballoons also known as Amorphous Silica, glass balls/bubbles or microspheres. They are free of any slivers and provide high-density, high-impact and high-strength properties for a variety of conservation applications.

In conservation Microballoons are primarily used as thickeners or fillers for thixotropic mixes particularly adhesives, castings and consolidants.

Microballoons have been found to be particularly effective when mixed with consolidants such as Paraloid B72 to infill woodworm damaged areas on furniture and musical instruments such as violins and woodwind instruments.

Having a completely spherical shape and being free of slivers the heavier grades have also been used successfully to maintain the position of delicate or three-dimensional glass and ceramics objects undergoing conservation treatment, ensuring artefacts are free of excess tension and abrasion.

Safety issues: Microballoons contain no substances classified as hazardous to health according to EC directives. However, due to their fine particle sizes we recommend the use of suitable eye and face protection when handling at close quarters.



Specifications

- Spherical
- Free of any slivers

Applications

- Used as thickeners or fillers for thixotropic mixes particularly adhesives, castings and consolidants

Product code	Description	Weight	Pack qty
SUMICR0001	1.00 to 1.25mm diam. balls	500g pot	1
SUMICR0003	Fine powder version for filling mixes	500g	1

Corn Starch Powder

Chemically neutral corn starch powder, offering high viscosity and brightness.

Ready-prepared corn starch paste is available but subject to a minimum order of 300kg.



Product code	Capacity
SUCAMI0001	1kg pot
SUCAMI0005	5kg bucket
SUCAMI0010	10kg bucket

Wheat Starch Powder

European wheat starch powder producing a traditional-style paste generally used for Japanese restoration methods. When dry this adhesive is transparent and reversible with water. It can be mixed with methycellulose for additional flexibility.

Ready-prepared wheat starch paste is available but subject to a minimum order of 300kg.



Product code	Capacity
SUWHSP7521	250g
SUWHSP7522	2.5kg

Long-Life Sterilised Wheat Starch Paste

A ready-to-use, laboratory-made sterilised wheat starch paste in an aerosol spray which may keep for up to two years.



Product code	Description	Capacity ml	Pack qty
SUSWSP0050	LL Sterilised wheat starch paste	50	1
SUSWVG0050	LL Sterilised wheat starch paste without gluten	50	1

Bookbinders Starch Paste

A starch paste for bookbinding, mounting and repair. An integral fungicide improves this product's shelf life. pH6 gluten-free.



Product code	Description	Weight kg	Pack qty
SUBBSP1650	pH6 Gluten-free starch paste	1	1

Rice Starch Powder

Offering a great fluidity and greater whiteness than Corn Starch.

Ready-prepared rice starch paste is available but subject to a minimum order of 300kg.



Product code	Capacity
SURISP7525	250g pot
SURISP7527	5kg bucket
SURISP7528	10kg bucket

Paste Ring

This little device is literally 'handy', being a ring with a container that allows you to carry a small amount of paste, adhesive or colour to wherever you are working. Ideal for close work where full attention is required. It will comfortably fit most fingers and for the really dextrous more than one ring can be worn at a time. Useful for Conservators, Framers and Artists.



Product code	Description	Container size
EQRING0001	Plastic Ring with Liquid Container	18mm diameter x 9mm depth

Norikoshi Sieve and Noribon Paste Bowl

Traditional Japanese copper-banded wooden bowl and sieve used for mixing and making fine Jin Shofu paste. Can be purchased separately.



Noribon Wooden Bowl



Norikoshi Sieve

Product code	Description	Container size
SUNSSN6595	Norikoshi sieve	230mm diameter x 110mm depth
SUNTWB6594	Noribon wooden bowl	361mm diameter x 90mm depth

Yuki Flakes™, Ready-Cooked Japanese Tapioca Starch

A quick and easy-to-prepare, non-ionic, Japanese Tapioca starch which has been pre-cooked and freeze-dried, producing white, snow-like flakes that can easily be dissolved in cold water to produce a smooth, pH-neutral paste for conservation and bookbinding. It can be used with Japanese and other tissue papers for lining and repair of fragile documents and books. It can also be used by framers requiring a safe but quickly prepared adhesive for artwork hinges using Japanese paper.



 **Linked Products:** *Whisper Tissue™ p99-p100 and Japanese brushes p216.*

Specifications

- Available in 500g and 1000g plastic containers
- Appearance: white flakes
- % of water contained: less than 10%
- pH: 6 to 8
- Viscosity: 6000-10000cps (mPa's) based on RH 11%, 25°, 20rpm
- Ionic character: non-ion
- Dissolution: soluble by cold water

Features

- No need to cook
- Easy to dissolve in water without lumps
- Easy to homologue
- Stable for freezing and defrosting
- Non-ionic paste, hardly affected by acid or alkali
- No formalin contained

How to dissolve Yuki Flakes™

- Add a small amount of the Yuki Flakes™ to water (ratio of flakes to water: 1 to 7/8)
- Stir the mix to make a stream then stop
- Then add the rest of the Yuki Flakes™ into the water and start stirring again immediately
- Keep stirring for 5 minutes then leave it for 15 minutes
- Stir again for 1 minute and you have clear liquid starch paste ready to use

Product code	Weight kg
SUYPTS0500	0.5
SUYPTS1000	1

Jin Shofu Paste

For making traditional Japanese double-refined wheat starch paste. Mix approximately 1 part Jin Shofu to 3 or 4 parts water.

Heat mixture over a low flame and stir continuously. When it becomes clear remove it from the heat and let it cool before using. A finer paste can be obtained by using a Norikoshi sieve. The mixed paste can be stored in plastic or glass jars in a refrigerator.

Shofu Paste



Product code	Description	Weight g
SUSHFU0001	Jin Shofu paste	500

Laponite Powder

Inorganic and synthetic product with a structure very similar to natural clay which gives its absorbent properties. Laponite is a white powder, which, when mixed with water, forms a 'thixotropic' gel (it softens while stirring and hardens once again at rest).

When a poultice is applied to porous surfaces, Laponite gel gives moisture without tidelines. The gel can also be used with solvents.

 *Linked Products: Cleaning products p200 and erasers p209-210*

Applications

Removal of residual adhesives.

The gel is easily removed without leaving a sticky surface.

When applied to a large surface, it is advisable to use a non-woven polyester as an intermediary to help remove the poultice.

Product code	Weight	Pack qty
SUAPLA0500	500g Laponite Powder	1

Laponite Gel

The Laponite gel is an inorganic synthesis which has adsorption properties. This is a version ready to use, avoiding the problems of dosing and the quality of solvents such as water. It is produced in a laboratory in small, precisely-controlled batches.



Product code	Description	Capacity
SULAPG0100	Laponite Gel	100ml

Natural Clay

Natural Clay mixed with water for the removal of glue residue. This is offered in a ready-to-use tube, avoiding the problems of dosing and the quality of solvents such as water. It is produced in a laboratory in small precisely-controlled batches.



Product code	Description	Capacity
SUNACLO100	Natural Clay	100ml

Tylose MH300P

Methylcellulose in the form of white powder. Neutral and reversible chemically. High viscosity in low concentration, highly resistant to biological degradation, non-toxic, stable pH. Stored in a dry atmosphere and at room temperature Tylose has a long shelf-life. Like paper, it absorbs water in moist air and gives off water in dry air. Totally transparent when dry. Its tack is less than starch paste, but it gives more flexibility and dries slower. Tylose can be mixed with starch paste to combine the flexibility of the first and the good tack of the second.

Applications

Pasting, laminating and lining using Japanese or European tissue papers.

Pasting guards and hinges for mounting. Re-sizing agent to replace traditional gelatine-size. Mounting or repair in place of starch paste or in addition to starch paste. Surfactant agent: used as a viscid poultice to remove stains or water-soluble adhesives. Anti-flocculent agent in the paper pulp (for filling losses), Tylose helps to keep fibres separated in the water.

Product code	Weight g	Pack qty
SUAPTY0500	500	1
SUAPTY0100	100	15

Klucel G/E (Hydroxypropylcellulose)

A non-ionic cellulose ether with a remarkable combination of properties making it of great interest to the book conservator for use as a consolidant. Highly surface-active. Extremely flexible without plasticisers in films and coatings. Available in medium-viscosity(G) and also now in a low-viscosity(E) quality.



Klucel E may be subject to availability.

Specifications

- pH5 to 8.5 (1.5% solution)
- Ash content 0.5% max (calculated as Na2SO4)
- Viscosity (2% solution): 150 — 400MPAS
- Soluble in water below 38°C (insoluble in water above 40°C)
- Soluble in many polar organic solvents e.g. methyl alcohol, ethyl alcohol, isopropyl alcohol (95%)
- Insoluble in toluene, xylene, trichloroethylene

Applications

- Used as a consolidant in book conservation.

Product code	Description	Capacity	Pack qty
SUKLUC7156	G trial size	100g	1
SUKLUC0001	G standard/medium viscosity	1kg	1
SUKLUC7213	E trial size	100g	1
SUKLUC0002	E low-viscosity	1kg	1

Wurth Neutral Curing Silicone Sealant

This translucent, neutral-curing silicone sealant has passed all three Oddy tests (Copper, Silver and Lead) which means it is approved for permanent use in museum showcases. It has been used by CXD for many of our prestigious museum showcase installations. It can be used in conjunction with standard sealant applicators.



Product code	Description	Capacity ml
SUSILI3101	Silicone Sealant	310

Dow Corning Silicone Sealants

Museum-approved, neutral-curing silicone sealants produced by Dow Corning for museum showcase use. Available in White, Clear or Black. The special 310ml cartridges can be used in conjunction with the optional Wexford applicator.



SUSILI0744 SUSILI7091

Product code	Description	Colour	Capacity ml	Pack qty
SUSILI0744	Silicone Sealant	White	310	1
SUSILI3145	Silicone Sealant	Clear	310	1
SUSILI7091	Silicone Sealant	Black	310	1

Wexford Applicator

Sealant applicator can be used in conjunction with the 310ml Silicone Sealant Cartridges.



Product code	Description	Pack qty
SUWEXA7082	Wexford applicator	1

Sodium CMC Carboxymethyl Cellulose Gabrosa P200G Wallpaper Adhesive

A granular, dry-powder wallpaper adhesive soluble in water. Technical Grade >70% Purity. The recommended concentration is 1.925%. A 25kg bag should be sufficient to stick 1400 rolls of light-weight paper. For blown vinyl papers it is recommended that the concentration be increased to 2.27% which will make 1100 litres of paste and would stick between 1000 and 1200 rolls of paper.

Product code	Description	Weight kg	Pack qty
SUSCMC7041	Sodium carboxymethyl cellulose	1	1
SUSCMC7283	Sodium CMC high-purity grade	1	1
SUSCMC7284	Sodium CMC gabrosa	1	1

Culminal® MC2000 Methylcellulose

Culminal® Methylcellulose derivatives are cellulose ethers which, when dissolved in water, offer a variety of functional properties. Culminal® products are granular powders and are used as thickeners, protective colloids, stabilisers, suspension aids and water-retention agents in many industrial applications. Culminal® is easily soluble in cold water though not soluble in hot water.

Culminal® is a non-ionic cellulose ether and is compatible with many surfactants and polymers such as starch, guar and alginates. Solutions of Culminal® are pseudoplastic, with some solutions showing thixotropy. The solution viscosity is a function of the temperature; as the latter increases viscosity decreases.

When reaching the gel temperature gelling and flocculation of the polymer will occur. This process is reversible upon cooling. Viscosity is nearly independent of the pH over a wide range. Culminal® cellulose ethers have many functional properties, such as water-retention, thickening and stabilizing action, binding ability, adhesion, protective colloid, suspension effect and emulsion stabilisation and film formation.

Specifications

- Detailed information on the physical and chemical properties of Culminal® Methylcellulose derivatives are available on request. According to the EC legislation on dangerous substances and preparations Culminal® products are not hazardous. Further information on Culminal® MC is available on the Safety Data Sheet.

Product code	Description	Weight
SUMCCL6625	Culminal MC2000	1kg

Linen Bookbinding Cord

Since the early 1980s, fine linen cord has become very difficult to source. It is an essential material for the conservation bookbinder and CXD are pleased to be able to offer this range of cords.

Available Ex Stock in 4 ply; 6 ply; 8 ply; 10 ply; 12 ply all in 1kg spools. Other plies available to special order

Product code	Description	Weight per reel kg	Pack qty
SULBBC1408	4ply	1	1
SULBBC0006	6ply	1	1
SULBBC0008	8ply	1	1
SULBBC0010	10ply	1	1
SULBBC0012	12ply	1	1

Traditional bookbinding using linen cord



Dispenser and Adhesive

Self-adhesive tapes and dispenser with raised applicator wheel for better visibility and greater accuracy. 12mm or 19mm high-quality, acid-free, acrylic, double-sided tape benefiting from instantaneous adhesion, with no drying or cockling.



NOTE: Although the acrylic adhesive has a great chemical stability, it is not suitable for use with archival documents. Direct contact with valuable documents should be avoided. Two types of double-sided transfer tape are available:

Type 1, Permanent adhesive tape (Ref. SUAPAD0001/0002) recognisable by the brown release paper and Type 2, Temporary adhesive tape (Ref. SUAPAD0001) recognisable by its white release paper. Please note that, although it is possible to attach and take off a document adhered with the temporary tape, a polymerisation occurs with time and it will be more and more difficult to remove the document.

Product code	Description	Size mm	Size inches	Pack qty
SUAPAD0003	Dispenser only			1
SUAPAD0001	Refill tape	12 x 33m	1/2 x 108ft 3/2	8 Rolls
SUAPAD0002	Refill tape	19 x 33m	3/4 x 108ft 3/2	1 Roll

Mini-Adhesive Tape Dispenser

This handy mini-dispenser places small double-sided adhesive rectangles at regular spacings. 2 or 4 adhesive rectangles are enough to provide durable mounting. The dispenser uses a permanent non-reversible, acid-free acrylic adhesive which, although it has passed the PAT test, is not recommended for photographs or documents of value or historic significance. It is however a useful tool for all common spot-gluing of ephemeral, non-archival items.



Each disposable mini dispenser contains 650 rectangles of double-sided acrylic adhesive, Size: 12 x 8mm. Supplied in individual blister packs.

Product code	Description
SUAPSQ0650	Dispenser with 650 adhesive rectangles



- SULBBC1408
4ply
- SULBBC0006
6ply
- SULBBC0008
8ply
- SULBBC0010
10ply
- SULBBC0012
12ply



Tapes

Heritage Archival pHotokraft™ Gummed Tape

Conservation-quality mounting and framing tape. A combination of strength and purity, developed to a high specification using Heritage Archival pHotokraft™ (HAPK) Paper.

It features a water-activated, neutral pH, reversible, starch adhesive for conservation hinging and mounting of artwork, photographs, ephemera, manikin supports and many other uses.



Specifications

Paper:

- 90gsm
- Acid-free and lignin-free
- Buffered with calcium carbonate
- pH7.5 to 8.5

Adhesive:

- Acid-free, water-activated starch adhesive
- pH7.5
- Passed the Photographic Activity Test (PAT)
- FATG level – Conservation

LONG LIFE



Product code	Size mm	Size inches	Thickness gsm	Colour	Pack qty
SUAFTP7417	24 x 50m	15/16 x 164ft 1/2	90	White	1
SUAFTP7418	24 x 200m	15/16 x 656ft 2/64	90	White	1
SUAFTP7419	48 x 100m	15/64 x 3284 1/64	90	White	1

100% Cotton Gummed Paper Tape

This is a white, acid-free, pH neutral 100% cotton paper with 2% calcium carbonate buffer and a pH neutral gum adhesive system.

Can be used with confidence to hinge almost anything.



Product code	Size mm	Size inches	Colour	Pack qty
SUAFTC7375	25 x 30m	63/64 x 98ft 5/64	White	1

Lineco - Hayaku Gummed Japanese Paper Tape

Hayaku is a Japanese Mulberry Paper coated with acid-free, water-activated and reversible adhesive.

A ready-made, fast alternative to handmade Japanese paper hinges. It has passed the PAT test ANSI ISO 18916 and is used for hinging works of art on paper, paper repair and structural applications in art, bookbinding, memorabilia and object conservation.



Product code	Size mm	Size inches	Pack qty
SUAFTC7375	25 x 30m	63/64 x 98ft 5/64	1

Japanese Handmade Hinging Paper

This 100% Kozo paper is made on a mould with raised lines running parallel to the short side. They are spaced at different intervals to produce hinging strips of different widths. They produce water-marked lines where the paper fibre is thinner. This facilitates easy tearing along the waterline where it has been moistened with a wet brush. Once moistened the thin strip can be detached from the main sheet. Water cutting gives a fine feathered edge avoiding sharp lines where it is attached to the document or picture to be mounted. Use with starch pastes, heat-activated acrylic, EVA or other adhesives as required.



[Linked Products: Adhesives p127 and Brushes p216.](#)

Product code	Description	Size mm	Size inches	Pack qty
SUJPH6043	Japanese KOZO hinging tissue	430 x 600	163/64 x 233/64	1



CXD Archival Gummed Linen Hinging Tape

A non-yellowing, water-activated, starch-based, acid-free adhesive pH7.5 coated on a strong, white, calendared, cotton fabric. Mainly used for hinging mounts/mats and hanging heavy artwork but also used for repair or reinforcing books and paper documents etc.



Product code	Size mm	Size inches	Pack qty
SUALTC7148	25 x 150m	1½ x 492ft 1 ³³ / ₆₄	1
SUALTC7149	38 x 150m	2 x 492ft 1 ³³ / ₆₄	1
SUALTC7150	50 x 150m	1½ x 98ft 5 ⁵ / ₆₄	1
SUALTC7169	25 x 30m	2 x 98ft 5 ⁵ / ₆₄	1
SUALTC7170	50 x 30m	4 x 98ft 5 ⁵ / ₆₄	1

CXD Gummed Tyvek® Tape

Conservation-quality, gummed tape for mounting, framing and bookbinding developed by Conservation By Design. Tyvek® is a synthetic fibre made from spun-bonded Polyolefin which is inert and acid-free. Made using 105gsm Tyvek® 1057 D with a water-activated, starch adhesive, pH7.5.



This tape offers greater strength yet is thinner than conventional gummed cloth-mounting tapes. This is beneficial when used for hinging over-mounts to be stored in Solander boxes as it will create less 'fanning' to the taped side, which means the mounts will lay flatter. It has many other uses including the production of custom-made portfolios by combining the Black and White versions. Available in White and Black. Activate with a damp sponge, roller or fine mist spray. Do not over-moisten as this may remove the adhesive from the tape.

Specifications

- 105gsm
- Acid-free
- Tyvek® 1057
- Water-activated starch adhesive pH7.5
- FATG level – Conservation



Applications

- Mounting
- Hinging
- Box, folder and portfolio construction

Product code	Colour	Size mm	Size inches	Pack qty
SUTAPE7537	White	24 x 50m	1 ⁵ / ₁₆ x 164ft ½	1
SUTAPE7538	White	24 x 200m	1 ⁵ / ₁₆ x 656ft 2 ¹ / ₆₄	1
SUTAPE7539	White	48 x 100m	1 ⁷ / ₆₄ x 328ft 1 ¹ / ₆₄	1
SUTAPE7540	White	96 x 50m	3 ²⁵ / ₃₂ x 164ft ½	1
SUTAPE7541	Black	48 x 100m	1 ⁷ / ₆₄ x 328ft 1 ¹ / ₆₄	1
SUTAPE7542	Black	96 x 50m	3 ²⁵ / ₃₂ x 164ft ½	1



Filmoplast SH, Self-Adhesive Cotton Fabric Tape

A fine, white, cotton, neutral-pH, self-adhesive tape. For quick hinging of mounts/mats for when a Fine Art Trade Guild Museum standard is not required. Applications include hinging window mounts/mats, making portfolios etc.

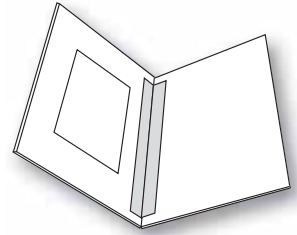

Product code	Size mm	Size inches	Pack qty
SUFILS1325	13 x 25m	3 ³ / ₆₄ x 82ft ½	1
SUFILS2025	20 x 25m	2 ⁵ / ₃₂ x 82ft ¼	1
SUFILM7236	30 x 25m	1 ¹ / ₁₆ x 82ft ¼	1

Tyvek® Self-Adhesive Tape

A Tyvek® tape for when speed is of the essence or a water-activated adhesive is inappropriate.

The high-strength, chemically inert advantages of Tyvek® are combined here in the form of 3.1cm x 30m tenacious self-adhesive tape.



Specially designed for the reinforcement and repairing of hinges for books, boxes, exercise books and notebooks. Also useful for hinging mounts/mats and making portfolios.

Product code	Size mm	Size inches	Pack qty
SUTATY3130	31 x 30m	1½ x 98ft 5 ⁵ / ₆₄	1

Filmoplast T Coloured Self-Adhesive Cotton Fabric Tapes

Stocked in White and Black but also available to special order in a total of eight natural, dyed colours. This pressure-sensitive 240 micron, acid-free, cotton tissue tape is finished with an acrylic protective coating and adheres with a neutral pH7, solvent-free, acrylic adhesive which is elastic and permanent. It has been developed for use on standard library and archive material. It is useful for repairing book spines and lining maps and plans. It is also used for dust-sealing picture frames. Being self-adhesive, we do not recommend its use on rare books or items of historical value.



Colour chart on request.

Product code	Colour	Size mm	Size inches	Pack qty
SUFILTO001	White	50 x 10m	1 ³ / ₃₂ x 32ft 9 ⁴⁵ / ₆₄	1
SUFILTO002	White	80 x 10m	3 ¹ / ₃₂ x 32ft 9 ⁴⁵ / ₆₄	1
SUFILTO003	Black	50 x 10m	1 ³ / ₃₂ x 32ft 9 ⁴⁵ / ₆₄	1
SUFILTO004	Black	80 x 10m	3 ¹ / ₃₂ x 32ft 9 ⁴⁵ / ₆₄	1

Archival Aids Document Repair Tape

Archival Document Repair Tape was developed in association with government archives and libraries for the temporary repair of documents and bindings to enable both safe handling and use until a more satisfactory repair can be made. The transparent base-paper is 100% Manilla fibre 9.3gsm CXD Spider tissue coated on one side only with an archivally approved Butyl-Acrylate 'Acrylic' adhesive that contains a very small percentage of Dibutyl-phthalate plasticiser (to enable the tape to be pressure-sensitive). The pH of the material is between 7.0 and 7.5.



The tape should be applied to both sides of the damaged item where possible.

Even after artificial ageing Archival Document Repair Tape proved to be reversible using a suitable spirit solvent.

To remove the tape, first place a piece of archival blotting paper under the item. Then, with a lightly moistened swab of cotton wool containing a suitable solvent, gently dab the surface of the tape. After a minute or so the base-paper will lift off revealing the acrylic adhesive. Gently dab the adhesive layer with a remoistened swab and after a few minutes the adhesive layer will also be removed.

Care should always be taken when removing Archival Document Repair Tape from ephemera with suspect spirit-based inks. The use of Industrial Methylated Spirits is recommended although other solvents may work faster. Safety regulations should be observed when handling all solvents.

The tape can also be used for labelling.

Product code	Description	Size mm	Size inches	Pack qty
SUDRTA0001	Coated archival tissue	25 x 30m	4 ³ / ₆₄ x 98ft 5 ⁵ / ₆₄	1
SUDRTA0003	Coated archival tissue	25 x 350m	4 ³ / ₆₄ x 1148ft 3 ¹ / ₂	1

Lineco Mending Tissue

A long-fibred, non-yellowing transparent pressure-sensitive paper tape for temporary document repairs.

Coated on one side the neutral pH adhesive is removable with solvents. Tested and approved for use in archives. Supplied in a handy box dispenser.



Product code	Size mm	Size inches	Pack qty
SUDRTD1315	13 x 15m	3 ³ / ₆₄ x 49ft 2 ⁵ / ₆₄	1
SUDRTD2529	25 x 29m	4 ³ / ₆₄ x 95ft 1 ¹ / ₆₄	1

Filmoplast P – Transparent

A wood-free, transparent, wafer thin, self-adhesive, paper-based tape using an acrylic adhesive system.

Both the paper base and acrylic adhesive have a pH of 8.5.

Unlike Document Repair Tape, Filmoplast P is removable with water and is therefore best-suited for use with solvent-based printing inks.



Product code	Description	Colour	Size mm	Size inches	Pack qty
SUFILM5360	Self-adhesive Paper Tape	Clear	20 x 50m	2 ⁵ / ₃₂ x 164ft 1/2	1
SUFILM4050	Self-adhesive Paper Tape	Clear	40 x 50m	1 ⁷ / ₆₄ x 164ft 1/2	1

Filmoplast P90 – Opaque

A white, opaque, self-adhesive, paper-based tape using an acrylic adhesive system, which is designed to strengthen and repair cellulose fibres.



Product code	Description	Colour	Size mm	Size inches	Pack qty
SUFILP1350	Self-adhesive Paper Tape. P90	White	13 x 50m	3 ³ / ₆₄ x 164ft 1/2	1
SUFILM6253	Self-adhesive Paper Tape. P90	White	20 x 50m	2 ⁵ / ₃₂ x 164ft 1/2	1
SUFILP4050	Self-adhesive Paper Tape. P90	White	40 x 50m	1 ³ / ₆₄ x 164ft 1/2	1

Frame Sealing Tape

Self-adhesive, aluminium, foil-lined, paper acid and moisture-barrier tape.

A multi-purpose, pressure-sensitive, paper tape, featuring an aluminium foil barrier layer to prevent the migration of harmful elements contained in raw wood. For example: frame rebates, wooden fillets or frame backs. It also creates a moisture barrier when used to seal frame packages. The paper layer is acid and lignin-free and buffered to pH8.5 with 3% calcium carbonate. A strong, acid-free acrylic adhesive is applied to the aluminium foil layer that will adhere to raw wood. It conforms to surface imperfections and the stable adhesive will not crack, dry out or go yellow. Remove with mineral spirits.



Do not apply to artwork.

Product code	Size mm	Size inches	Colour	Pack qty
SUFRST3225	32 x 25m	1 ¹ / ₆₄ x 82ft 1/4	Grey	1

Volara® (acid-free) Foam Rabbet Tape

This acid-free .03" (800 micron) thick Volara® closed-cell polyethylene inert foam tape features an aggressive, acrylic, pressure-sensitive adhesive for lining frame rabbets/rebates. The foam provides padding and a smooth slippery surface to protect canvases, digital art, mirrors and oils from abrasion or sticking to the rebate.



Product code	Description	Colour	Size mm	Size inches	Pack qty
SUVRTP3632	Volara Tape	Black	6.35 x 32.9m x 800 micron	1/4 x 107ft 11 ¹ / ₂ x 1/2	1

Aluminium Gas-Barrier Tape 425

Scotch® Aluminium Foil Gas-barrier Sealing Tape. A Scotch 425 Aluminium Foil Adhesive Tape has previously passed the Oddy test for permanent exhibition use with copper, silver and lead but requires periodic re-testing as recommended by conservation scientists. The tape can be used in conjunction with Moistop PP004 Barrier Foil or Corrosion Intercept® RIBS Barrier Foil.



Product code	Size mm	Size inches	Thickness mm	Pack qty
SUALUM0425	50 x 50m	3 ¹ / ₂ x 164ft 1/2	0.12	1
SUALUM5515	15 x 50m	1/2 x 164ft 1/2	0.12	1
SUALUM5525	25 x 50m	3/4 x 164ft 1/2	0.12	1

Glass Protection Tape

A blue-coloured, self-adhesive polyester masking tape with a silicone adhesive for operations involving high temperatures and pressure. Useful to protect framed glass in transit or as a protective film during sand-blasting. Preferred for its ease of application and removal.



Product code	Description	Colour	Size mm	Size inches	Pack qty
SUTAPE8901	Self-adhesive powder-coated (3M-8901)	Blue	25 x 66m	6 ³ / ₄ x 216ft 6 ⁷ / ₆₄	1

Aplix 800. Hook and Loop Self-Adhesive Nylon Coins and Tapes

Aplix 800 is a two-part fixing system of hooks and loops made of white nylon and supplied as coins or tapes backed with a strong pressure-sensitive adhesive. Each dispenser contains both parts.



Applications: Box/folder closures, fixing items on temporary exhibition and many more.

Product code	Description	Size mm	Size inches	Pack qty
SUAPLX0150	Coin	Ø20	5/2	1
SUAPLX2525	Tape	25 x 25m	3/4 x 82ft 1/4	1
SUAPLX2550	Tape	20 x 5m	5/2 x 16ft 4 ⁷ / ₂	1

Ø = Diameter

Pink Legal Tape

Cotton yarn-dyed Pink Legal Tape typically used for office legal paper. Wash/bleed of 4/5 respectively with light-fastness of 5.



Product code	Description	Size mm	Size inches	Pack qty
SUTAPL0013	Pink Legal Tape	10 x 100m	2/4 x 328ft 1/64	1

Cotton Tying Tape Unbleached

An unbleached, narrow cotton tape specifically designed for tying up bundles of documents, phase boxes and for use with the CXD range of folders.



 **Linked Products:** CXD range of folders p42 and Phase Boxes p11-12.

Product code	Colour	Size mm	Size inches	Pack qty
SUCTMB0004	Off White	20 x 50m	2 ³ / ₂ x 164ft 1/2	1
SUCTMB6621	Off White	13 x 50m	3 ³ / ₄ x 164ft 1/2	1
SUCTMB6622	Off White	13 x 50m	3 ³ / ₄ x 164ft 1/2	1

* SUCTMB6622 is of higher quality and conforms to BS1625.

Heritage Library Tape™

This 100% Cotton Heritage Library Tape™ was designed by Caroline Bendix, renowned book conservator and advisor to the National Trust, to sympathetically protect loose or detached hard covers of books in heritage libraries by providing discreet support and holding the book together.



Created to be bleed-resistant, fade-proof and in the pH neutral range, the tying tape prevents boards from becoming separated from the textblock. It also reduces the risk of a dilapidated book being further damaged when neighbouring volumes are removed from the shelf.

The cotton typing tapes complement CXD's range of Sepia and Duke Parchment colour Premier Duo™ Archival Folding Boxboard, which is made specifically for the production of bookshoe supports in order to blend discreetly with leather, vellum or parchment bindings.

Colours: Mid Brown, Dark Brown, Parchment.

For further information and a testimonial from Caroline, please see our website.

 **Premier Boxboard:** Sepia and Duke Parchment colours p110; Portable Rolling Creaser p176; Evacon-R™ p127. Manual and digital book measure p176 and Conservac p200.

Product code	Colour	Size	Size inches	Pack qty
SUCHTT7735	Mid Brown, 100% cotton	13 x 50m	3 ³ / ₄ x 164ft 1/2	1
SUCHTT7736	Dark Brown, 100% cotton	13 x 50m	3 ³ / ₄ x 164ft 1/2	1
SUCHTT7737	Parchment, 100% cotton	13 x 50m	3 ³ / ₄ x 164ft 1/2	1

Natural Linen Tape

Natural Linen Sewing Tape, offered as standard in 13mm.



Product code	Description	Size mm	Size inches	Pack qty
SUTAMB9213	Natural Linen Tape	13 x 100m	3 ³ / ₄ x 328ft 1/64	1

Buckram Cloth 100% Cotton

Covering cloth for books, boxes and portfolios. Water and bleed-resistant acrylic-varnished finish.

Thickness: 0.32mm.

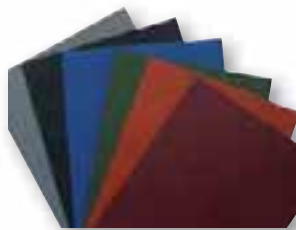

Colour swatch: available on request.

 *Linked Products Evacon-R™ p127 and Superior Millboard p8, 112.*

Product code	Colour	Size mm	Size inches	Weight g	Pack qty
SULBCL0001	Maroon	1060 x 5m	3ft 5 ¹¹ / ₆₄ x 16ft 4 ⁷ / ₃₂	235	1
SULBCL0002	Red	1060 x 5m	3ft 5 ¹¹ / ₆₄ x 16ft 4 ⁷ / ₃₂	235	1
SULBCL0003	Green	1060 x 5m	3ft 5 ¹¹ / ₆₄ x 16ft 4 ⁷ / ₃₂	235	1
SULBCL0004	Blue	1060 x 5m	3ft 5 ¹¹ / ₆₄ x 16ft 4 ⁷ / ₃₂	235	1
SULBCL0005	Black	1060 x 5m	3ft 5 ¹¹ / ₆₄ x 16ft 4 ⁷ / ₃₂	235	1
SULBCL0006	Grey	1060 x 5m	3ft 5 ¹¹ / ₆₄ x 16ft 4 ⁷ / ₃₂	235	1

Double or Single-sided Polyester Archival Tape

The original archival pressure-sensitive tape product made by 3M™ and used for polyester encapsulation. A double-sided acrylic, adhesive polyester tape.

This product is not recommended for direct contact with original material as a mounting tape.



 *Linked Products: Polyester Rolls p77.*

Product code	Description	Size mm	Size inches	Pack qty
SUPTDS0001	Double-Sided Tape (3M-415M)	6 x 33m	1 ¹⁵ / ₆₄ x 108ft 3 ¹ / ₃₂	1
SUPTDS0002	Double-Sided Tape (3M-415M)	12 x 33m	1 ¹⁵ / ₃₂ x 108ft 3 ¹ / ₃₂	1
SUPTDS0003	Double-Sided Tape (3M-415M)	19 x 33m	3 ³ / ₄ x 108ft 3 ¹ / ₃₂	1
SUPTSS0001	Single-Sided Tape (3M-850M)	9 x 66m	2 ²³ / ₆₄ x 216ft 6 ²⁷ / ₆₄	1
SUPTSS0002	Single-Sided Tape (3M-850M)	12 x 66m	1 ¹⁵ / ₃₂ x 216ft 6 ²⁷ / ₆₄	1
SUPTSS0003	Single-Sided Tape (3M-850M)	19 x 66m	3 ³ / ₄ x 216ft 6 ²⁷ / ₆₄	1

See-Thru Polyester Mounting Strips

Mounting strips for adhesive-free hingeless mounting. Made from a combination of rigid transparent polyester film, 30mm width, mounted on a self-adhesive-backed, acid-free card 20mm wide which is thick enough to raise the polyester above most items being mounted. Simply position the print or photograph in place and adhere strips to the mount/mat backing board. No adhesive ever comes in contact with the artwork. Instead, the art is cradled by the overlapping 10mm of inert archival polyester and is ready to be framed. Available in regular 102mm (4") or economical 305mm (12") strips. Packed in boxes of 60. They can be cut to size as required.

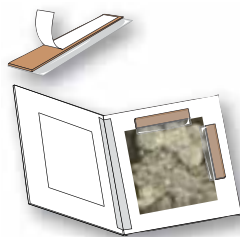

Product code	Size mm	Size inches	Pack qty
SUPYMS3010	30 x 102	1 ¹ / ₁₆ x 4 ¹ / ₆₄	Box of 60
SUPYMS3030	30 x 305	1 ¹ / ₁₆ x 4 ¹ / ₆₄	Box of 60

Triangle PET Museum Mounting Corners

Simply peel off the backing strip and these chemically inert top-of-the-range polyester mounting corners are ready to use. The polyester is backed by a water-based, acrylic, pressure-sensitive, solvent-free adhesive. Available in two sizes, 13mm (3³/₆₄") and 35mm (1¹/₈"). The design of the mounting corner is such that the adhesive does not come into contact with the materials being mounted.



Complies with ANSI IT 9.16 Photographic Activity Test. PAT Passed.

Applications

For mounting artwork, photographs, postcards etc.

Product code	Size mm	Size inches	Pack qty
PYSUMC0013	13	3 ³ / ₆₄	Box of 240
PYSUMC0035	35	1 ¹ / ₈	Box of 240

Larson Juhl Conservation Corner Mounts

A lower price alternative to polyester, these pre-formed mounting corners are made from polypropylene which contains no plastifying agents harmful to conservation. They are completely transparent with a water-based acrylic adhesive containing no solvents. The design ensures no adhesive comes in contact with the item being mounted. Available in 3 sizes: 19mm (3³/₄"), 32mm (1¹/₄"), 75mm (2¹⁵/₁₆") and 2 styles: Full Corners and Maxi-Vision. Supplied in an easy-to-use dispenser.



Complies with ANSI IT 9.16 Photographic Activity Test. PAT Passed.

Product code	Size mm	Size inches	Pack qty
SUPPCR0842	1 19	3 ³ / ₄	Box of 250
SUPPCR0844	2 32	1 ¹ / ₄	Box of 250
SUPPCR0845	3 32	1 ¹ / ₄	Box of 250
SUPPCR0846	4 75	2 ¹⁵ / ₁₆	Box of 100
SUPPCR0847	5 75	2 ¹⁵ / ₁₆	Box of 100

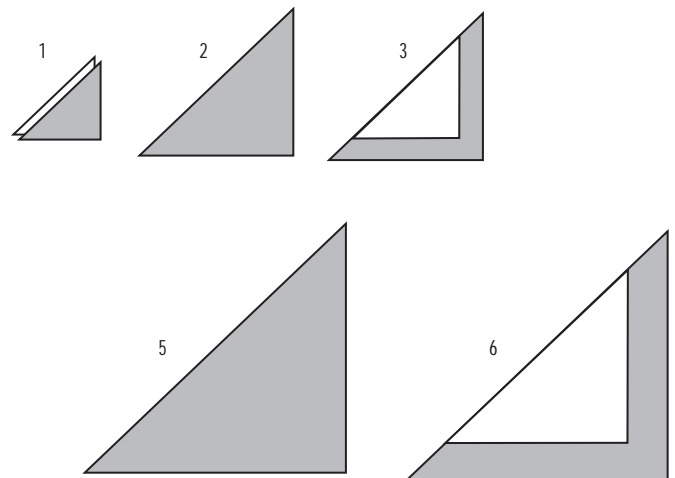

V Mount Polyester Strips

V Mount Strips are glass clear polyester with an acrylic-adhesive backing. Ideal for holding photographs and documents securely yet unobtrusively in position on the mounting insert. The mount strips adhere to the mounting sheet to firmly hold the item.



Simply cut two strips to the desired length, locate over opposite sides of the item, remove the adhesive release paper strips, and press into position on the mounting sheet.

The mounting strips allow instant removal of the mounted items and remounting as often as desired.

Supplied in packs of 25 strips 200mm long.

Product code	Thickness microns	Size mm	Size inches	Pack qty
PVVMST0200	75	L 200	7 7/8	25

HOW TO USE
in 6 easy steps.
Examples of how V Mounts can be used to secure an item

Polyester Display Strips

Inert 75-micron polyester strip. These strips are useful for holding manuscripts open in a display or for unobtrusively securing items in a showcase.

Product code	Thickness microns	Size mm	Size inches	Pack qty
PYDISS0001	75	38 x 559	1 1/2 x 22	Box of 100

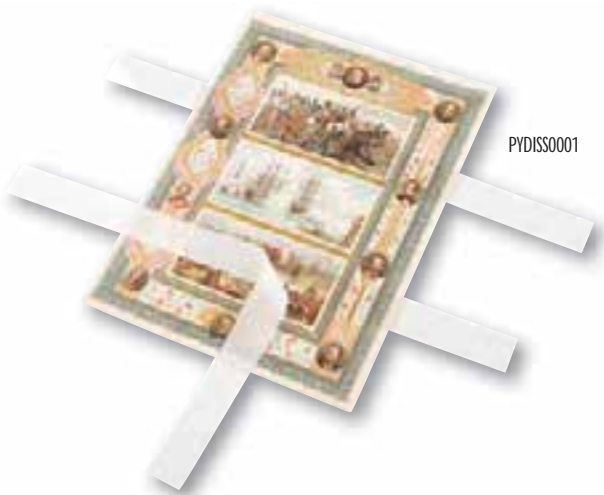

Corner Mounting Strips

Inert 75-micron polyester strip for mounting larger items. These transparent rectangular strips have two pressure-sensitive, acrylic-adhesive tabs at opposite ends. Useful for temporarily securing items for transportation or for positioning prints to a baseboard for framing. If used as a strap, care should be taken not to place the adhesive tab next to the item. Available in 2 styles, 'Folded' or 'Unfolded'.

The Unfolded style can also be creased using a template to form a corner pocket thereby avoiding the adhesive coming into contact with the item.

Product code	Size mm	Size inches	Style	Pack qty
PYSUMS0002	16 x 16	5/8 x 5/8	Folded	Box of 100
PYSUMS0001	22 x 22	55/64 x 55/64	Folded	Box of 100
SUCOMO6591	11 x 38	7/16 x 1 1/2	Unfolded	Box of 100
SUCOMO6592	20 x 100	25/32 x 3 15/16	Unfolded	Box of 100

SUCOMO6591
Unfolded

PYSUMS0002
Folded



Brother P-touch HI05 Label-Maker

Get organised with the P-touch HI05. Every new Planorama® cabinet order is supplied with a P-touch machine to help our customer and ensure that the stylish drawers are not spoiled by unsightly labels. Each drawer handle has a full-width channel designed to take a 12mm Matt Silver P-touch label matching the anodised aluminium of the drawers. They have been so well-received that we decided to offer them to all our customers.



They are simple to use, produce high-quality labels and increase efficiency by ensuring items are clearly identified. The compact handheld P-touch HI05 will have many uses within museums, libraries, archives and conservation studios. Also useful in the office or at home for boxes, folders, CD cases, shelving, filing cabinets and for personal possessions. With a wide variety of tape cassettes in various widths and colours it will soon become an indispensable tool.

Brother P-touch laminated TZe tapes consist of six layers of materials, resulting in a thin yet extremely strong label. The thermal transfer ink is sandwiched between two protective layers of PET (polyester film), which protects the text against the effects of liquids, abrasion, temperature, chemicals and sunlight.

- Easy-to-use label Auto Design function
- 9 font styles, 178 symbols, 7 frames
- Includes 12mm black on white label cassette
- Prints 3.5, 6, 9 and 12mm labels
- 20 languages: (English, German, French, Spanish, Portuguese, Italian, Dutch, Danish, Norwegian, Swedish, Finnish, Hungarian, Czech, Polish, Romanian, Slovenian, Slovakian, Croatian, Turkish, Brazilian)

Requires 6 x AAA (LR03) alkaline batteries (not supplied)

Linked Products: Planorama p172 and p233, Boxes. p7.

Product code	Description	Size mm	Size inches
EQPTLH1050	Brother P-touch label printer PT-H105	12 x 8m	15/32
EQPTTZ0335	Brother P-touch 12mm labelling black print on white	12 x 8m	15/32
EQPTTZ0435	Brother P-touch 12mm labelling white print on red	12 x 8m	15/32
EQPTTZ0931	Brother P-touch 12mm labelling black print on silver	12 x 8m	15/32



Example of labelling

Archival Self-Adhesive Labels

A product range developed to the requirements of the Dutch National Archive in Den Haag. High-quality, archival, self-adhesive labels made with CXD Archival Rag Endleaf paper. The labels have good adhesion to most substrates. Very stable acrylic-based adhesives with minimum plasticisers. Suitable for use with all computer printer types including laser printers, they are currently sold in sheets which can feed automatically from the paper tray of most desktop printers.

Conservation By Design Archival Rag Endleaf is an exceptionally high-quality paper developed for conservation bookbinding e.g. endpapers, guarding etc. It is manufactured from 100% cotton fibre. The paper has successfully been designed to meet the most stringent standards required by conservation binderies, libraries, and museums. It has a smooth-wove surface, buffered with calcium carbonate and tub-sized with a pure non-ionic oxidised farina starch to resist fibre-picking when printing and to impart extra fold surface strength to the paper. The paper is specified to pass recognised Silver Tarnish Tests. PAT passed.

Specifications

Paper Stock – White, CXD Archival Rag Endleaf

- 100% cotton
- Acid-free and buffered with calcium carbonate
- pH8.5 (hot extract)
- Tub-sized with pure non-ionic oxidised farina starch
- High fold strength before and after accelerated ageing tests
- Light-fast, Blue Wool Scale = 5
- Archibond Adhesive SA9/2, 25gsm modified poly butyl acrylate/resin
- Adhesive reversible with industrial spirit. Based on highly successful and long-used Document Repair Tape Adhesive



Product code	Description	Colour	Label size mm	Label size inches	Pack qty sheets
SUAFLS0001	A4 – 1 per sheet	Natural White	210 x 297	8 ¹¹ / ₁₆ x 11 ¹¹ / ₁₆	100
SUAFLS0004	A4 – 4 per sheet	Natural White	150 x 103	5 ²⁹ / ₃₂ x 4 ¹ / ₁₆	100
SUAFLS0006	A4 – 6 per sheet	Natural White	80 x 100	3 ¹ / ₂ x 3 ⁵ / ₁₆	100
SUAFLS0009	A4 – 9 per sheet	Natural White	63 x 96	2 ³ / ₄ x 3 ²⁵ / ₃₂	100
SUAFLS0027	A4 – 27 per sheet	Natural White	63 x 32	2 ³ / ₄ x 1 ¹ / ₄	100
SUAFLS0036	A4 – 36 per sheet	Natural White	50 x 30	1 ³ / ₂ x 1 ¹ / ₁₆	100
SUAFLS0045	A4 – 45 per sheet	Natural White	38 x 31	1 ¹ / ₂ x 1 ¹ / ₃₂	100
SUAFLS0072	A4 – 72 per sheet	Natural White	16 x 48	5/8 x 1 ⁵ / ₄	100
SUAFLS0084	A4 – 84 per sheet	Natural White	46 x 11	1 ¹³ / ₁₆ x 1/16	100
Labels on a roll					
SUAFLP0001	Sprocketed labels		111 x 60		1000
SUAFLP0002	Sprocketed labels		111 x 60		5000

Other sizes can be made to special order

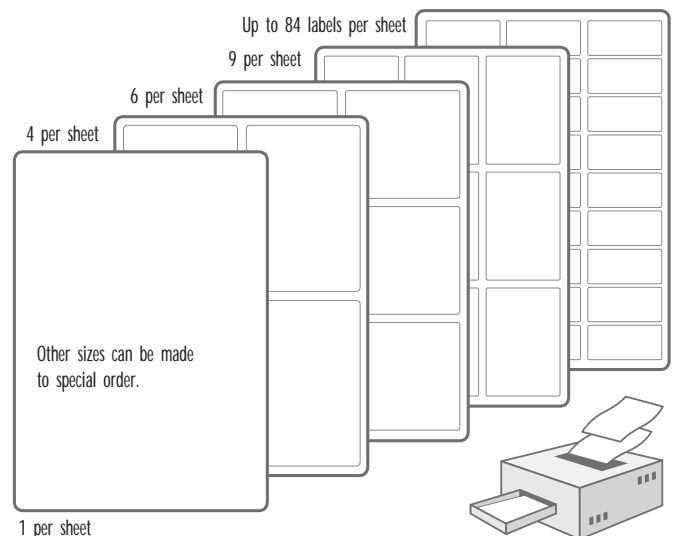

Aluminium Foil-Backed Archival Quality Adhesive Labels

White, acid-free paper labels backed with aluminium foil coated with an acrylic adhesive. They adhere strongly and the aluminium foil prevents the adhesive solvents being absorbed by the label paper thereby causing the label to dry out and drop off. It also prevents the penetration of ink through the label which might damage the object. The label corners have radiused to avoid corner-lift.



Product code	Description	Size mm	Size inches	Pack qty
SUALBL0001	Continuous/Perforated	76 x 101	2 ⁶³ / ₆₄ x 3 ³¹ / ₃₂	1000
SUALBL0002	Continuous/Perforated	50 x 75	1 ³² / ₃₂ x 2 ⁶¹ / ₆₄	1000
SUALBL0003	Sheets	76 x 101	2 ⁶³ / ₆₄ x 3 ³¹ / ₃₂	150
SUALBL0004	Sheets	20 x 25	2 ⁵ / ₃₂ x 6 ³ / ₆₄	1000
SUALBL0005	Sheets	20 x 38	5/32 x 1 1/2	1000
SUALBL0006	Sheets	25 x 50	6 ³ / ₆₄ x 1 ³¹ / ₃₂	1000
SUALBL0007	Sheets	20 x 63	2 ⁵ / ₃₂ x 2 ³¹ / ₆₄	1000
SUALBL0008	Sheets	50 x 75	3 ¹ / ₃₂ x 2 ⁶¹ / ₆₄	225

Heritage Archival pHotokraft™ Swing Labels

Identification labels made of White Heritage Archival pHotokraft™ permanent paper 170gsm or 350gsm, acid-free, lignin-free, with alkaline reserve, complying with the ISO 9706 standard. PAT passed. Can be supplied unbuffered on request. Single or double holes to attach tying strings. Brass eyelets are fitted on some items to give extra strength and can be specified for an extra cost on others if required. A 300mm cotton tail is attached to the short side of the brass eyeleted 350gsm item only. Ties are not supplied as standard on the other labels.



Applications

Identification of museum objects or archival documents, archaeological objects, textiles etc.

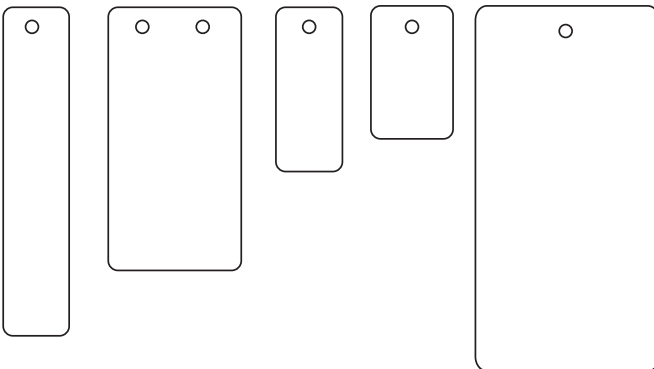

Product code	Description	Colour	Size mm	Size inches	Pack qty
SUHAPL0001	Perforated	White	20 x 100	2 ⁵ / ₃₂ x 3 ¹⁵ / ₁₆	500
SUHAPL0002	Perforated	White	25 x 40	6 ³ / ₆₄ x 1 ³⁷ / ₆₄	500
SUHAPL0003	Perforated	White	25 x 50	6 ³ / ₆₄ x 1 ³¹ / ₃₂	500
SUHAPL0004	Perforated	White	40 x 80	1 ³¹ / ₆₄ x 3 ⁵ / ₃₂	250
SUSWNG7001	Perforated with eyelet and washer	White	75 x 120	2 ⁶¹ / ₆₄ x 4 ²³ / ₃₂	1

Tyvek® Swing Labels and Tags

Identification labels and non-perforated tags made of Tyvek® I00g, a synthetic paper made from spun-bonded polyethylene fibres. A chemically inert material which will accept writing and offset printing.

An alternative to labels made from Heritage Archival pHotokraft™ Paper. Tyvek® labels are waterproof and offer greater mechanical strength for the safe labelling of artefacts within the workshop and objects store. (Ties not supplied.)

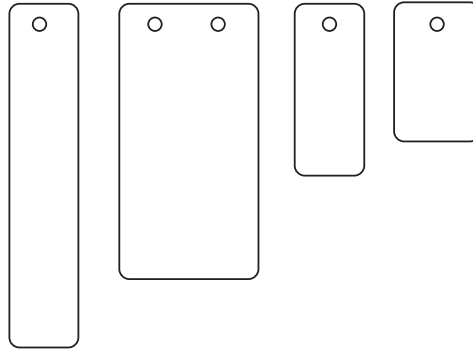

Product code	Description	Colour	Size mm	Size inches	Weight gsm	Pack qty
SUTYLA0001	Perforated	White	20 x 100	2 ⁵ / ₃₂ x 3 ¹⁵ / ₁₆	105	500
SUTYLA0002	Perforated	White	25 x 40	6 ³ / ₆₄ x 1 ³⁷ / ₆₄	105	500
SUTYLA0003	Perforated	White	25 x 50	6 ³ / ₆₄ x 1 ³¹ / ₃₂	105	500
SUTYLA0004	Perforated	White	40 x 80	1 ³¹ / ₆₄ x 3 ⁵ / ₃₂	105	250

Non-Archival Paper Swing Labels

Economical, but strong, white-lined card swing labels ready fitted with red-coloured tying string. The paper is not of archival quality but, for the identification of items which are not too sensitive and where the budget is restricted, these labels will do the job nicely. Available in three sizes.



Product code	Label size mm	Label size inches	Pack qty
ETICFIL1828	18 x 28	4 ⁵ / ₆₄ x 1 ¹ / ₆₄	100
ETICFIL2538	25 x 38	6 ³ / ₆₄ x 1 1/2	100
ETICFIL3250	32 x 50	1 ¹¹ / ₆₄ x 1 ³¹ / ₃₂	100

Archival Polypropylene Label-Holders with Paper Inserts

A range of transparent, non-plasticised, archival-quality polypropylene label-holders with acid-free, acrylic pressure-sensitive adhesive. Very good adherence to any smooth, clean surface. Supplied with white detachable paper inserts.



Suitable for

Identifying Ringbinder Boxes, Archive Boxes, Folders, Shelves and a variety of other applications.

Product code	Description	Label size mm	Label size inches	Pack qty
SUPPLH0001	Polypropylene label-holder	15 x 102	$7\frac{1}{32}$ x $4\frac{1}{64}$	20
SUPPLH0002	Polypropylene label-holder	25 x 75	$6\frac{3}{64}$ x $2\frac{61}{64}$	12
SUPPLH0003	Polypropylene label-holder	25 x 102	$6\frac{3}{64}$ x $4\frac{1}{64}$	12
SUPPLH0004	Polypropylene label-holder	35 x 75	$1\frac{3}{8}$ x $2\frac{61}{64}$	12

Concorde Aluminium Label-Holders with Self-Adhesive Backing

A range of rigid aluminium adhesive-backed label-holders open on the narrow side.

Epoxy-paint finish in Black or Grey. On the back are two self-adhesive strips which stick firmly to any clean, dry, smooth surface. Pre-punched holes allow them to be riveted for a firmer fix if preferred.

Perfect for identifying museum-style, cloth-covered boxes and ring binders.



Product code	Size mm	Size inches	Colour	Accepts label	Pack qty
SUALLH0001	95 x 30	$3\frac{7}{64}$ x $1\frac{1}{16}$	Grey	A	1
SUALLH0002	160 x 48	$6\frac{19}{64}$ x $1\frac{13}{64}$	Grey	B	1
SUALLH0003	160 x 48	$6\frac{19}{64}$ x $1\frac{13}{64}$	Black	B - Non-adhesive	1
SUALLH0004	95 x 30	$3\frac{7}{64}$ x $1\frac{1}{16}$	Black	A	1
SUALLH0005	160 x 48	$6\frac{19}{64}$ x $1\frac{13}{64}$	Black	B	1

Labels for Concorde Aluminium Label-Holders

Labels made of white 170gsm permanent paper in sizes suitable for the Concorde aluminium label-holder range. Polyester protection inserts to cover the labels are available on request.



Product code	Size mm	Size inches	Label reference	Pack qty
SUALLH0006	28 x 94	$1\frac{1}{64}$ x $3\frac{5}{64}$	A	50
SUALLH0007	45 x 158	$1\frac{9}{64}$ x $6\frac{1}{32}$	B	50

Shelf Dummies

Grey, fluted, polypropylene, shelf dummy. Size 200 x 200mm with step-numbering allowing for positioning at the shelf-edge and ensuring immediate visibility on shelves – supplied with a label, with its label-holders located on a dummy side. Light, solid and durable, they naturally blend in to any library.



Product code	Description	Pack qty
SUPPBD0001	Dummy with label on right	25
SUPPBD0002	Dummy with label on left	25

Paper Clips

Solid brass paper clips, large and small.

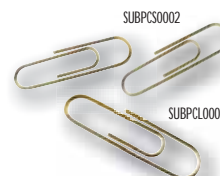

Product code	Description	Size mm	Size inches	Pack qty
SUBPCL0001	Large paper clip	33		500 per bag
SUBPCS0002	Small paper clip	22		500 per bag

Polystyrene Paper Clips

Light-weight polystyrene paper clips which are chemically neutral. Supplied in matching colour boxes.



Colours may vary from those illustrated.

Product code	Description	Size mm	Size inches	Pack qty
SUPPPC0001	Paper clips - polystyrene	21	$5\frac{3}{64}$	Box of 100
SUPPPC0002	Paper clips - polystyrene	25	$6\frac{3}{64}$	Box of 100
SUPPPC0003	Paper clips - polystyrene	25	$6\frac{3}{64}$	Box of 1000
SUPPPC0004	Paper clips - polystyrene	35	$1\frac{3}{8}$	Box of 30
SUPPPC0005	Paper clips - polystyrene	100	$3\frac{15}{16}$	Box of 100

Label Holders Self-adhesive

Multi purpose transparent label holders for vertical or horizontal use. The pockets open on the short edge, and are supplied with white paper inserts. These neat, well-designed label holders are available in three sizes, are easy to use and suitable for a variety of applications.

Applications

- Ideal for titling archive boxes, ringbinders, folders, labelling shelves, letter trays and many other applications.
- Re-labelling is simple and the strong adhesive makes sure the labels stay in place

Product code	Description	Colour	Label size	Pack qty
SUHKBL6614	Short side opening	Clear	50 x 103	60

Pens, Pencils and Inks

Photographic Marker Pencil

Used to temporarily reference or mark the back of photographs or prints. This is not suitable for modern resin-coated prints.



Product code	Description	Colour	Pack qty
SUPHMP0001	Photographic Marker Pencil	Graphite	12

Pigma Micron Pens

Pure black pigment ink, pH neutral, fade-resistant, waterproof, chemical-resistant and conforms to ASTM-04236. Works well on porous surfaces such as paper, wood and fabric.



Product code	Description	Colour	Size mm	Pack qty
SUPIGM0005	Pigma micron pens, pH neutral	Black	0.005pt (0.20mm)	1
SUPIGM0010	Pigma micron pens, pH neutral	Black	0.01pt (0.25mm)	1
SUPIGM0020	Pigma micron pens, pH neutral	Black	0.02pt (0.30mm)	1
SUPIGM0030	Pigma micron pens, pH neutral	Black	0.03pt (0.35mm)	1
SUPIGM0050	Pigma micron pens, pH neutral	Black	0.05pt (0.45mm)	1
SUPIGM0080	Pigma micron pens, pH neutral	Black	0.08pt (0.50mm)	1

Packs of 12 pens available - (Any size on request)

Artline 883 CD/DVD Pen

Special marking pen for CD-R and DVD. 0.5mm polyester fibre point. Permanent pigment ink.



Product code	Description	Colour	Size mm	Pack qty
SUPNCD0883	CD/DVD marker pen	Black	0.5	1

Uni Power Tank Eco Ballpoint Pen for Wet Paper

The ideal pen for those who work outside. Perfect for gadget lovers. Writes at 360 degree angle (upside down). Cold-resistant ink that will not freeze in temperatures as low as -20°C. Writes on wet paper.



Product code	Description	Colour	Pack qty
SUPNWP0220	Ballpoint pen for writing on wet paper	Black	1

Mechanical Pencil

Professional-quality technical drawing pencil. The diameter of the HB lead is identified by the colour bands: Yellow 0.3mm, Red 0.5mm, Blue 0.7mm, Green 0.9mm. Brass Morse key. Metal ribbed grip. Equipped with gradation-indicator at top of metal structured collar. Reinforced lead: 20% more solid than traditional lead.

Extreme-density lead for clean and detailed tracing. Includes a tip-cleaner for use in event of obstruction.



Product code	Description	Size mm	Pack qty
SUPNCL3552	Yellow band	0.3	1
SUPNCL5552	Red band	0.5	1
SUPNCL7552	Blue band	0.7	1
SUPNCL9552	Green band	0.9	1

Uni Pin Ultra-Fine Water and Fade-Resistant Pigment Pens

An ultra-fine marker with smooth-flowing pigment ink that features superior water-resistance so, once it dries, the ink will not smear, even if water is spilt on the page. Being light-resistant makes the Pin a great art tool as work can be displayed and will not fade even under continuous exposure to light.

Line width: 0.05mm, 0.1mm, 0.2mm, 0.3mm, 0.4mm, 0.5mm, 0.8mm. Stock Colour: Black with Blue and Red available to special order.



Product code	Line width mm	Colour	Pack qty
SUPNUF5200	0.05mm	Black	1
SUPNUF1200	0.1mm	Black	1
SUPNUF2200	0.2mm	Black	1
SUPNUF3200	0.3mm	Black	1
SUPNUF4200	0.4mm	Black	1
SUPNUF5200	0.5mm	Black	1
SUPNUF8200	0.8mm	Black	1
SUPNUF5125	Assorted pack. 0.05/0.1/0.2/0.5mm	Black	4
SUPNUF3458	Assorted pack. 0.3/0.4/0.5/0.8mm	Black	4

Felt-Tip Administration Pen

Ideal for administrative work, documents, labels, etc. Does not bleed through paper. Dense colours.

Nylon felt-tip, flexible and resistant.



Product code	Colour	Pack qty
SUPNAP0001	Black	1
SUPNAP0002	Blue	1
SUPNAP0003	Red	1

Uni Super Ink, Oil-Based Permanent Pigment Marker

Ideal for use as a CD marker. Writes on a wide variety of materials including: fabric, plastic, glass, metal and paper. Will not fade with time and is light, water, bleach and acetone-resistant.

Line width : 0.9mm fine line.



Product code	Size mm	Colour	Pack qty
SUPNPI0125	0.9	Black	1

Edding 2000C Bullet-Tip and 2200C Chisel-Tip Permanent Markers

High-quality permanent markers from Edding for writing on, and labelling, virtually all materials – even metal, plastic and glass. Light-fast, quick-drying ink. Water and wear-resistant. All models are refillable.

Low-odour ink with no added toluene/xylene.

Edding 2000C Bullet-tip size:

3mm tapering to a 1.5mm point.

Edding 2200C Chisel-tip size: 1 x 5mm.

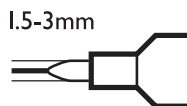

Product code	Description	Size mm	Colour	Pack qty
SUPMED0001	Model 2000C - Bullet-tip	3mm tapering to a 1.5mm point	Black	1
SUPMED0002	Model 2000C - Bullet-tip	3mm tapering to a 1.5mm point	Blue	1
SUPMED0003	Model 2000C - Bullet-tip	3mm tapering to a 1.5mm point	Red	1
SUPMED0004	Model 2000C - Bullet-tip	3mm tapering to a 1.5mm point	Green	1
SUPMED0005	Model 2200C - Chisel-tip	1mm x 5mm	Black	1
SUPMED0006	Model 2200C - Chisel-tip	1mm x 5mm	Blue	1
SUPMED0007	Model 2200C - Chisel-tip	1mm x 5mm	Red	1
SUPMED0008	Model 2200C - Chisel-tip	1mm x 5mm	Green	1

Edding 950 Industry Painter

Highly permanent colour paint stick with excellent opacity, which is light-fast, smudge-proof and water-resistant after drying. Ideal for difficult marking and labelling applications such as rough surfaces, unclean materials and rusty metals.



Product code	Description	Colour	Pack qty
SUPMED0009	Bullet-tip permanent marker, 10mm stroke	Black	1
SUPMED0010	Bullet-tip permanent marker, 10mm stroke	White	1
SUPMED0011	Bullet-tip permanent marker, 10mm stroke	Red	1

Edding 400/404 Bullet-Tip Permanent Markers

High-quality permanent markers for writing on, marking and labelling virtually all materials – even metal, plastic and glass. Light-fast, quick-drying ink. Water-resistant and wear-resistant.

All models refillable. Low-odour ink with no added toluene/xylene.

Bullet-tip in 2 thicknesses. Edding 400: 1mm, Edding 404: 0.75mm.



Product code	Model	Size mm	Colour	Pack qty
SUPMED0012	Edding 400 - Bullet-tip	1	Black	1
SUPMED0013	Edding 400 - Bullet-tip	1	Blue	1
SUPMED0014	Edding 400 - Bullet-tip	1	Red	1
SUPMED0015	Edding 400 - Bullet-tip	1	Green	1
SUPMED0016	Edding 404 - Bullet-tip	0.75	Black	1
SUPMED0017	Edding 404 - Bullet-tip	0.75	Blue	1
SUPMED0018	Edding 404 - Bullet-tip	0.75	Red	1
SUPMED0019	Edding 404 - Bullet-tip	0.75	Green	1

Edding 751/780 Paint Marker

Permanent, low-odour pigment ink providing an opaque lacquer finish. Particularly good on dark and transparent materials and really smooth surfaces, such as glass. Waterproof, quick-drying, extremely light-fast and smudge-proof when dry. Ink flow regulated by a special valve.

Bullet-tip in 2 thickness: Edding 751: 1 to 2mm. Edding 780: 0.8mm.



Product code	Model	Size mm	Colour	Pack qty
SUPMED0020	Edding 751	1-2	Black	1
SUPMED0021	Edding 751	1-2	White	1
SUPMED0022	Edding 751	1-2	Silver	1
SUPMED0023	Edding 751	1-2	Gold	1
SUPMED0024	Edding 780	0.8	Black	1
SUPMED0025	Edding 780	0.8	White	1
SUPMED0026	Edding 780	0.8	Silver	1
SUPMED0027	Edding 780	0.8	Gold	1

Book Support and Display



Image courtesy of Dr Williams's Trust and Library

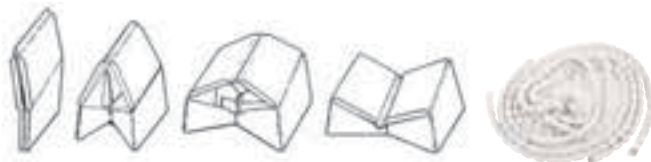

The companion set comes complete with double bean bag cushions for small, tight bindings, weighted book snakes and tubular spine support. Designed to fold flat for easy storage.

The Conservation Bookmate™ Companion Set

A Folding Book Support

The Conservation Bookmate™ is made from a high-density Plastazote® foam which is very light, rigid and strong. Plastazote® is made from nitrogen-expanded Polyethylene and as such is an inert material which neither degrades under the influence of UV light nor emits toxic fumes in a fire. It also has very good fold-strength which is of great importance for this product which is designed to fold flat for easy storage. Although lightweight the Conservation Bookmate™ is very stable and is strong enough to support large and heavy volumes.

The Conservation Bookmate™ incorporates two softer Plastazote® pads giving a gentle surface for delicate and uneven covers that may incorporate metal bosses or side-pins. Separate pads can be ordered particularly for use with thick volumes. These pads can be used to support the book board and lighter side of the text block as the reader turns the pages. The design has two front lips to stop the book sliding forward. Also incorporated is a space for hollow back and inflexible book spines. Support strips for tight-back bindings can also be supplied. The complete Companion set comes with a pair of 900mm weighted snakes, spine support tube and a special double-book cushion with washable cover that can be used in conjunction with the Conservation Bookmate™ when reading small tight-back volumes. Available in Coral Red or Charcoal. Single cushions also available on request. Many conventional reading supports tilt the book at too steep an angle which puts strain on the volume and can result in damage to the book. The Conservation Bookmate™ has an angle of tilt based on the Clarkson system set at 20° which allows the book to be read in comfort with a minimum of stress to the binding structure.

The Conservation Bookmate™ is durable and easy to clean. It can be washed if needed with cold soapy water to remove leather red rot or other contamination.

Registered Design No: 2050129. U.K. Patent No: 2 306 104 ; U.S. Patent No: 5,829,729.

Product code	Description
SUBKCS0001	Conservation Bookmate™ Companion Set
SUBKMT0001	Conservation Bookmate™ without cushion



SUBRCS0001 Conservation Bookmate™ Companion set with lead snakes

Clarkson Book Support System

Book Support System designed by Christopher Clarkson to cater for books with a wide variety of structural variations. The system is used in institutions throughout the world. The book support is built up from lightweight units of synthetic foam. Synthetic foam allows a book's uneven board surfaces, even with bosses and side-pins, to be equally supported over their entire exterior surface.

The particular density of foam was chosen for the important non-slip characteristic required and the grey colour was found preferable for a library environment. The concept of related units has dictated the use of generalised angles and dimensions in the design. Simplicity and ease of storage (impossible to achieve with combined tilt-and-wedge designs) are special features of the style. The units consist of three basic shapes in various format sizes:

Blunt Wedge

A pair of these wedges, plus one of the next larger format size for each regular 'place-setting'

Spine Support-Strip

Used when 'tight-back' (flexible) bindings are read.

Rectangular Pad

25mm (1") thick. Two pads would be the normal requirement for each 'place-setting', three may be needed for a very thick book.

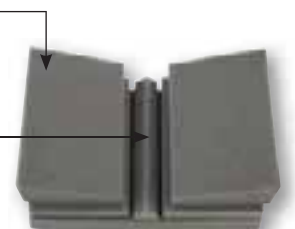

SUCBSS0001 Clarkson Book Support

Six units are required for each placement set. An optional seventh piece is available if an extra pad is required. Besides the synthetic foam units, one other piece of equipment is needed; a 'snake', which is a strap of weighted fabric used to hold the book open, two being required for each 'place setting'.

The book supports are available as 6-piece sets for each of the three sizes: Large, Medium and Small. The larger wedges can also be used by themselves to display single-sheet items at a reasonable reading angle.

 *Linked Products: Clarkson Bodleian system, see website.*

Product code	Description	Size mm	Size inches	Pack qty
SUCBSS0001	Small set	370 x 225	14 ¹ / ₁₆ x 8 ⁹ / ₁₆	1
SUCBSM0002	Medium set	500 x 348	19 ¹ / ₁₆ x 13 ⁹ / ₁₆	1
SUCBSL0003	Large set	760 x 470	29 ⁹ / ₁₆ x 18 ¹ / ₂	1

Lead Weights

Lead-shot filled, soft black leather and white cloth covered weights for holding down awkward items such as scrolls, deeds, plans and items on display.



SULEWE001

Product code	Description	Weight	Size mm	Size inches	Pack qty
SULEWE001	Circular	454g	90 Ø x 13 deep	3 ⁵ / ₆₄ x 3 ³ / ₆₄	1
SULEWE002	Snake Style	1.8kg	40 Ø x 610 long	1 ³ / ₆₄ x 24 ¹ / ₆₄	1
SULEWE003	Circular Mini Book	113g	60 Ø x 13 deep	2 ²³ / ₆₄ x 3 ³ / ₆₄	1

White, cloth-covered, snake-style lead weights, supplied in pairs:

Product code	Description	Weight	Size mm	Size inches	Pack qty
SUWBSL1001	Long	100g	2 x 1200	5/64 x 47 1/4	1
SUWBSL2001	Long	200g	2 x 1200	5/64 x 47 1/4	1
SUWBSS1009	Short	100g	2 x 900	5/64 x 35 1/6	1
SUWBSS2009	Short	200g	2 x 900	5/64 x 35 1/6	1

Ø = Diameter

Book Support Bags and Cushion Covers

A Society of Archivists Award Winner, designed by Susan Bradshaw. Proportioned to provide just the right degree of protective support for books, seals and other fragile, ephemeral material on display. Neutral colour for maximum visual appeal. Machine-washable, unbleached, calico, pillow-case style, cushion covers are available to extend the life of the Book Support Bags and to keep them clean. To preserve the quality of the Cushion Covers, cool wash and do not tumble dry.



Product code	Description	Colour	Size mm	Size inches	Pack qty
SUBSBB0001	Small cushion only	Buff	200 x 200	7 7/8 x 7 7/8	1
SUBSBB0002	Medium cushion only	Buff	400 x 400	15 3/4 x 15 3/4	1
SUBSBB0003	Large cushion only	Buff	500 x 600	19 11/16 x 23 5/8	1
SUBSBC0001	Small cover only	Buff	200 x 200	7 7/8 x 7 7/8	1
SUBSBC0002	Medium cover only	Buff	400 x 400	15 3/4 x 15 3/4	1
SUBSBC0003	Large cover only	Buff	500 x 600	19 11/16 x 23 5/8	1

Acrylic Book Stand 'Visitor' Model

Open, flat style made from sturdy 5mm acrylic, this visitor book stand has a reinforced base and acrylic front lips to prevent the book sliding forward. It is designed to present the visitor book at a good writing angle to encourage the visitor to enter comments.



Product code	Size guide	External dimension (L x H x D) mm	External dimension (L x H x D) inches	Pack qty
EQEDBK0001	A4	470 x 200 x 330	18 1/2 x 7 7/8 x 12 3/64	1

Acrylic Book Stand, 'Crystal Flat' Model

Open, flat style made from 10mm acrylic.



Product code	Size guide	External dimension (L x H x D) mm	External dimension (L x H x D) inches	Pack qty
EQEDBK0002	A4+	540 x 320 x 440	21 1/64 x 12 5/32 x 17 21/64	1

Acrylic Book Stand 'Standard Flat' Model

Open flat style made from 4mm or 5mm acrylic.



Product code	Size Guide	External dimension (L x H x D) mm	External dimension (L x H x D) inches	Pack qty
EQEDBK0003	A3	480 x 180 x 430	18 ⁵ / ₆₄ x 7 ¹ / ₃₂ x 16 ⁵ / ₆₄	1
EQEDBK0004	A4	420 x 150 x 390	16 ¹ / ₃₂ x 5 ⁹ / ₃₂ x 15 ²³ / ₆₄	1
EQEDBK0005	A5	280 x 110 x 280	11 ¹ / ₃₂ x 4 ¹ / ₃₂ x 11 ¹ / ₃₂	1

Acrylic Book Stand 'Open Book Rest' Model



Product code	Size guide	External dimension (L x H x D) mm	External dimension (L x H x D) inches	Pack qty
EQBOBR1000	A6	200 x 100 x 130	7 7/8 x 3 5/16 x 5 1/8	1
EQBOBR2000	A5	280 x 150 x 200	11 1/32 x 5 29/32 x 7 7/8	1
EQBOBR3000	A4	340 x 180 x 240	13 ²⁵ / ₆₄ x 7 3/32 x 9 29/64	1
EQBOBR4000	A3	660 x 280 x 410	25 63/64 x 11 1/32 x 16 3/64	1
EQEPPL1000	Prism Page Lock			1

Acrylic Book Stand 'Crystal Vertical' Model

Made of transparent acrylic so that the books can be examined from all angles. Designed so that books can be exhibited vertically in tower or wall showcases but can also be used flat for a table showcase.



Available in 5mm, 8mm, and 10mm acrylic.

Note: These are not reading lecterns.

Product code	Size guide	External Dimension (L x H x D) mm	External Dimension (L x H x D) inches	Pack qty
EQEDBK0021	A4	350 x 330 x 240	13 ²⁵ / ₃₂ x 12 ²⁵ / ₆₄ x 9 ⁹ / ₆₄	1
EQEDBK0022	A3	190 x 200 x 170	7 ³¹ / ₆₄ x 7 7/8 x 6 ¹ / ₁₆	1

Acrylic Book Stand, 'Anti-Theft' Model

Designed for the presentation and reading of books without risk of theft or damage. Made from sturdy 5mm thick transparent acrylic. Featuring acrylic overlaps which allow consultation while at the same time locking the book to the stand and thereby helping to prevent theft.



Product code	Size guide	External dimension (L x H x D) mm	External Dimension (L x H x D) inches	Pack qty
EQEDBK0006	A4	510 x 270 x 330	17 ²³ / ₃₂ x 9 ²¹ / ₃₂ x 12 ¹⁹ / ₃₂	1

Acrylic Book Stand 'Fold Away' Model

Can be assembled in modules and adapts to most works. Variable opening to prevent damage to the book binding. Multiple adjustment are possible depending on the size of the book and the number of pages to be displayed.



Product code	Max doc size	External dimension (L x H x D) mm	External dimension (L x H x D) inches	Pack qty
EQEDBK0007		400 x 220 x 220	15 ³ / ₄ x 8 ³ / ₃₂ x 8 ²⁷ / ₃₂	1
EQEDBK0009		450 x 360 x 350	17 ²³ / ₃₂ x 14 ¹¹ / ₆₄ x 13 ²⁵ / ₃₂	1

Acrylic Book Stand 'Crystal Display Easel' Model

Made from sturdy 5mm acrylic glass.



Product code	Size guide	External dimension (L x H x D) mm	External dimension (L x H x D) inches	Pack qty
EQEDBK0009	A3	300 x 400 x 450	11 ¹³ / ₁₆ x 15 ³ / ₄ x 17 ²³ / ₃₂	1
EQEDBK0010	A4	200 x 260 x 320	7 ⁷ / ₈ x 10 ⁵ / ₆₄ x 12 ²⁹ / ₃₂	1
EQEDBK0011	A5	130 x 300 x 180	5 ¹ / ₈ x 11 ¹³ / ₁₆ x 7 ¹ / ₃₂	1

Wooden Book Stand 'Prestige' Model

These high-quality, adjustable wooden lecterns allow the leaves to be laid out in 4 positions ensuring that books can be opened without risk of damage to the bindings. Built to last, they are hand-made by craftsmen using specially chosen solid woods.

Product code	Size guide	Max document size	External dimension (L x H x D) mm	External dimension (L x H x D) inches	Pack qty
EQEDBK0013	A3	A3 - height 37cm	640 x 480 x 420	25 ³ / ₆₄ x 18 ³ / ₆₄ x 16 ⁹ / ₃₂	1
EQEDBK0014	A4	A4 - height 25cm	440 x 320 x 300	17 ² / ₆₄ x 12 ⁹ / ₃₂ x 11 ⁹ / ₁₆	1
EQEDBK0015	A3 and column	A3 - height 37cm with column	640 x 1.37m x 420	25 ³ / ₆₄ x 53 ⁹ / ₁₆ x 16 ⁹ / ₃₂	1



Model A3: EQEDBK0013



Model A3: EQEDBK0015



Model A4: EQEDBK0014

Wooden Book Stand 'Closed Book' Model

Hand-crafted wooden lecterns to exhibit closed binding at a good height and angle. The solid wood construction is built to last. Available in two standard sizes for A5 and A4 books.

Product code	Size guide	Max document size cm	External dimension (L x H x D) mm	External dimension (L x H x D) inches	Pack qty
EQEDBK0016	A4	24 x 36	240 x 140 x 360	9 ⁹ / ₆₄ x 5 ³ / ₆₄ x 14 ¹¹ / ₆₄	1
EQEDBK0017	A5	17 x 25	170 x 80 x 250	6 ¹ / ₁₆ x 3 ³ / ₃₂ x 9 ²⁷ / ₃₂	1



Wooden Book Stand 'Incunable' Model

Made from solid wood and designed for consultation on a reading table. The Incunable holds the book in a comfortable position for the reader. Their fixed V-shaped panels prevent the book from being opened too flat. The standard incline may be too vertical for the text blocks of some fragile bindings but the A4 model can be fitted with an adjustable pivot (see reference: EQEDBK0020), which allows the book to be presented at various degrees of incline.

Available in two models: A4 and A3.

Product code	Size guide	External dimension (L x H x D) mm	External dimension (L x H x D) inches	Pack qty
EQEDBK0018	Upto A3. Maximum thickness of book 10cm	520 x 400 x 300	20 ⁵ / ₃₂ x 15 ³ / ₄ x 11 ¹³ / ₁₆	1
EQEDBK0019	Upto A4. Maximum thickness of book 8cm	410 x 350 x 230	16 ⁶ / ₆₄ x 13 ²⁵ / ₃₂ x 9 ¹ / ₁₆	1
EQEDBK0020	Upto A4. Includes adjustable stand. Maximum thickness of book 8cm	410 x 400 x 300	16 ⁶ / ₆₄ x 15 ³ / ₄ x 11 ¹³ / ₁₆	1



Model A3: EQEDBK0019



Model: EQEDBK0019



Model: EQEDBK0020

Acrylic 'Plate' Display Cradle

A range of acrylic cradles for supporting and displaying plates and circular objects that have been specially designed with a gentle slope and front lip to protect the object from damage while on display in a showcase.



Product code	Size guide mm	Working dimension mm	Working dimension inches	Pack qty
EQEDAC0101	Useable size 40 to 60	40 to 60	1 ³ / ₆₄ to 2 ³ / ₆₄	1
EQEDAC0102	Useable size 50 to 80	50 to 80	1 ³ / ₃₂ to 3 ⁵ / ₃₂	1
EQEDAC0103	Useable size 80 to 120	80 to 120	3 ⁵ / ₃₂ to 4 ² / ₃₂	1
EQEDAC0104	Useable size 120 to 180	120 to 180	4 ² / ₃₂ to 7 ¹ / ₃₂	1
EQEDAC0105	Useable size 150 to 250	150 to 250	5 ⁵ / ₃₂ to 9 ⁷ / ₃₂	1
EQEDAC0106	Useable size 250 to 350	250 to 350	9 ⁷ / ₃₂ to 13 ² / ₃₂	1

Acrylic 'Z' Shape Display Risers

A range of acrylic Z shape risers for objects while on display in a showcase.



Product code	External dimension (H x L x D) mm	External dimension (H x L x D) inches	Pack qty
EQEDAC0204	450 x 38 x 38	17 ²³ / ₃₂ x 1 ¹ / ₂ x 1 ¹ / ₂	1
EQEDAC0201	80 x 60 x 125	3 ⁵ / ₃₂ x 2 ²³ / ₆₄ x 4 ⁴⁹ / ₆₄	1
EQEDAC0202	120 x 60 x 180	4 ²³ / ₃₂ x 2 ²³ / ₆₄ x 7 ¹ / ₃₂	1
EQEDAC0203	80 x 100 x 200	3 ⁵ / ₃₂ x 3 ¹⁵ / ₁₆ x 7 ¹ / ₈	1

Acrylic 'U' Shape Display Risers

A range of acrylic U shape risers for objects while on display in a showcase.



Product code	External dimension (H x L x D) mm	External dimension (H x L x D) inches	Pack qty
EQEDAC0301	200 x 200 x 200	7 ⁷ / ₈ x 7 ⁷ / ₈ x 7 ⁷ / ₈	1
EQEDAC0302	150 x 150 x 150	5 ⁹ / ₃₂ x 5 ⁹ / ₃₂ x 5 ⁹ / ₃₂	1
EQEDAC0303	100 x 100 x 100	3 ¹⁵ / ₁₆ x 3 ¹⁵ / ₁₆ x 3 ¹⁵ / ₁₆	1
EQEDAC0304	50 x 50 x 50	1 ³ / ₃₂ x 1 ³ / ₃₂ x 1 ³ / ₃₂	1
EQEDAC0305	250 x 150 x 150	9 ⁷ / ₃₂ x 5 ⁹ / ₃₂ x 5 ⁹ / ₃₂	1
EQEDAC0306	100 x 200 x 100	3 ¹⁵ / ₁₆ x 7 ⁷ / ₈ x 3 ¹⁵ / ₁₆	1
EQEDAC0307	80 x 150 x 70	3 ⁵ / ₃₂ x 5 ⁹ / ₃₂ x 2 ³ / ₄	1

Acrylic Drum

Polished cylinders of solid, clear acrylic. The simplest and most effective way to set off an important piece.



Product code	External dimension (H x L x D) mm	External dimension (H x L x D) inches	Pack qty
EQACDR5025	50 x 25	1 ³⁷ / ₆₄ x 3 ⁶³ / ₆₄	1
EQACDR5050	50 x 50	1 ³¹ / ₃₂ x 1 ³¹ / ₃₂ x 1 ³¹ / ₃₂	1
EQACDR7525	75 x 25	2 ⁶¹ / ₆₄ x 3 ⁶³ / ₆₄	1
EQACDR7550	75 x 50	2 ⁶¹ / ₆₄ x 1 ³¹ / ₃₂	1
EQACDR1025	100 x 25	3 ¹⁵ / ₁₆ x 3 ⁶³ / ₆₄	1
EQACDR1050	100 x 50	3 ¹⁵ / ₁₆ x 1 ³¹ / ₃₂	1

Acrylic Solid Blocks

Solid block of polished acrylic.



Product code	External dimension (H x L x D) mm	External dimension (H x L x D) inches
EQACSB0015	40 x 40 x 15	1 ³⁷ / ₆₄ x 1 ³⁷ / ₆₄ x ¹⁹ / ₃₂
EQACSB0025	65 x 65 x 20	2 ⁷ / ₁₆ x 2 ⁷ / ₁₆ x ²³ / ₃₂
EQACSB0030	75 x 75 x 40	2 ⁶³ / ₆₄ x 2 ⁶³ / ₆₄ x 1 ³¹ / ₃₂
EQACSB0035	90 x 90 x 20	3 ⁵ / ₁₆ x 3 ⁵ / ₁₆ x ²³ / ₃₂
EQACSB0040	100 x 100 x 40	3 ¹⁵ / ₁₆ x 3 ¹⁵ / ₁₆ x 1 ³¹ / ₃₂
EQACSB0041	100 x 100 x 25	3 ¹⁵ / ₁₆ x 3 ¹⁵ / ₁₆ x ⁶³ / ₆₄
EQACSB0042	100 x 100 x 50	3 ¹⁵ / ₁₆ x 3 ¹⁵ / ₁₆ x ³¹ / ₃₂
EQACSB0045	115 x 115 x 25	4 ¹⁷ / ₃₂ x 4 ¹⁷ / ₃₂ x ⁶³ / ₆₄
EQACSB0055	125 x 125 x 30	5 ¹ / ₂ x 5 ¹ / ₂ x 1 ¹ / ₄

Hanging Systems

Hanging Rails – U section

2mm steel hanging section, epoxy-painted, pre-perforated approximately every 30cm.

Thickness: 2mm.

Each rail is supplied with steel screws and a small pot of paint for retouching.



Product code	Size mm H x W x L	Size inches	Colour	Pack qty
EOCPHS0001	22 x 9 x 1m	0 ⁵ / ₆₄ x 0 ³ / ₆₄ x 39 ³ / ₈	White	1
EOCPHS0002	22 x 9 x 1.5m	0 ⁵ / ₆₄ x 0 ³ / ₆₄ x 59 ¹ / ₁₆	White	1
EOCPHS0003	22 x 9 x 2m	0 ⁵ / ₆₄ x 0 ³ / ₆₄ x 78 ³ / ₆₄	White	1

High-Strength 11/4 Hanging Rod

Rigid, strong steel rod, designed to carry large-format paintings and heavy objects. 11 x 4mm section - epoxy-paint.



Product code	Size mm H x W x L	Size inches	Colour	Pack qty
EOCPHS0004	11 x 4 x 1m	0 ⁷ / ₁₆ x 0 ⁷ / ₃₂ x 39 ³ / ₈	White	1
EOCPHS0005	11 x 4 x 1.5m	0 ⁷ / ₁₆ x 0 ⁷ / ₃₂ x 59 ¹ / ₁₆	White	1
EOCPHS0006	11 x 4 x 2m	0 ⁷ / ₁₆ x 0 ⁷ / ₃₂ x 78 ³ / ₆₄	White	1

Hooks for 11/4 Rods

Solid brass hook, weight-carried strength up to 100kg.



Product code	Description	Pack qty
EOCPHS0013	Maximum loading 100kg	1

4/4 Hanging Rod

Complementary to the U section, the hanging rod is plainly designed and fits into any kind of environment – 4 x 4mm square section rod, epoxy-painted.



Product code	Size mm H x W x L	Size inches	Colour	Pack qty
EOCPHS0007	4 x 4 x 1m	0 ⁷ / ₃₂ x 0 ⁵ / ₃₂ x 39 ³ / ₈	White	1
EOCPHS0008	4 x 4 x 1.5m	0 ⁷ / ₃₂ x 0 ⁵ / ₃₂ x 59 ¹ / ₁₆	White	1
EOCPHS0009	4 x 4 x 2m	0 ⁷ / ₃₂ x 0 ⁵ / ₃₂ x 78 ³ / ₆₄	White	1

Hooks for 4/4 Rods (see image 4/4 Hanging Rod)

The strength of these hooks varies depending on the model, going from 10 to 45kg of weight carried and they are perfectly suitable for use with the 4/4 hanging rod.

Product code	Description kg	Pack qty
EOCPHS0010	Maximum loading 10kg	1
EOCPHS0011	Maximum loading 25kg	1
EOCPHS0012	Maximum loading 40kg	1

Anti-Theft Head for 4/4 Rods

High-locking mechanism which enables the rod to be locked on the rail without impeding sideways movement.



Product code	Description	Colour	Pack qty
EOCPHS0017	Lock to fit Classique anti-theft rod	White	1

Anti-Theft 4/4 Hook Rod

Prevents the hook from slipping off the bottom by means of a screw fitted to the end of the rod.



Product code	Size m	Size inches	Colour	Pack qty
EOCPHS0014	1	39 ³ / ₈	White	1
EOCPHS0015	1.5	59 ¹ / ₁₆	White	1
EOCPHS0016	2	78 ³ / ₆₄	White	1

Anti-Theft 4/4 Hook

Anti-theft hook for 4/4 rods, locked at the same height as the work of art by means of an anti-theft hook which is locked to the board frame.



Product code	Description	Pack qty
EOCPHS0018	Includes locking mechanism. Maximum loading 25kg	1

Anti-Theft Key

These three locks require the same, easy-to-use spanner: a hexagonal male tool that can be used at an angle of 35°.



Product code	Description	Pack qty
EOCPHS0018	Anti-theft key	1

Swivels For Fixing Stretched Canvases

Steel swivels on springs. For fitting stretched canvases in frames. Delivered with screw set.



Product code	Description	Pack qty
EQFROA0032	Swivels	1

Pure Linen Strapping and Welded D Rings

Finely woven pure linen strapping, width: 14mm, suitable for welded D rings.



Product code	Description	Size mm	Size inches	Pack qty
EQFROA0033	Linen braid	14 x 25m	$\frac{35}{64} \times \frac{63}{64}$	1
EQFROA0034	D ring for use with linen braid			250

Lost Head Nails



Product code	Size mm	Size inches	Pack qty
EQFROA0036	12-2	$\frac{15}{32} - \frac{5}{64}$	250
EQFROA0037	16-2	$\frac{5}{8} - \frac{5}{64}$	250
EQFROA0038	18-4	$\frac{45}{64} - \frac{5}{32}$	250
EQFROA0039	20-3	$\frac{25}{32} - \frac{1}{8}$	250

Nylon Cord

2mm diameter flexible nylon picture hanging cord.



Product code	Size mm	Size inches	Pack qty
EQFROA0027	2 x 100m	$\frac{5}{64} \times 328\text{ft } 1\frac{1}{64}$	1

EconoSpace®

A simple solution for conservation framing of floated artwork in a frame. They separate the glassing from the art and are available in two sizes. Made from extruded neutral pH plastic with a high-tack, acid-free acrylic adhesive on one side. For use with wood or metal frames.

Available 3 colours: White, Black and Transparent.

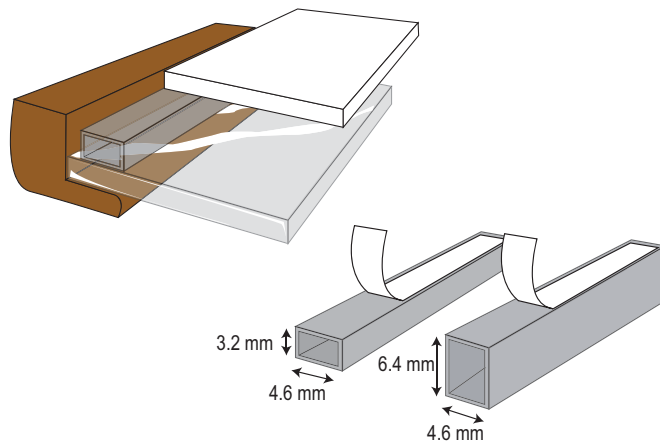

Product code	Colour	Dimensions mm	Dimensions inches	Pack qty
EAFREC0001	White	48 x 32 x 1520	$1\frac{5}{16} \times 1\frac{1}{4} \times 59\frac{1}{32}$	20
EAFREC0002	White	48 x 64 x 1520	$1\frac{5}{16} \times 2\frac{3}{4} \times 59\frac{1}{32}$	20
EAFREC0003	Black	48 x 32 x 1520	$1\frac{5}{16} \times 1\frac{1}{4} \times 59\frac{1}{32}$	20
EAFREC0004	Black	48 x 64 x 1520	$1\frac{5}{16} \times 2\frac{3}{4} \times 59\frac{1}{32}$	20
EAFREC0005	Transparent	48 x 32 x 1520	$1\frac{5}{16} \times 1\frac{1}{4} \times 59\frac{1}{32}$	20
EAFREC0006	Transparent	48 x 64 x 1520	$1\frac{5}{16} \times 2\frac{3}{4} \times 59\frac{1}{32}$	20

Extra-Fine Lightweight Cross-Peen Hammer

For very precise nailing work, hammer 28cm long, square peen measuring 12mm.



Product code	Description	Pack qty
EQFROA0035	Lightweight hammer	1



Clarity and Tru Vue® Glass and Acrylic

Optically coated to produce a near-invisible finish. To create its range of framing and conservation glass Tru Vue® uses its proprietary Magnetron-Sputtering technology to deposit precisely controlled layers of highly energised metal oxides onto a waterwhite glass substrate.

Clarity by Larson Juhl, Waterwhite Anti-Reflective Glass

Clarity has 70% UV filtering. The superb clarity gives this glass its name. It reduces reflections to less than 1% and what remains has a slight blue tinge found more appealing to the eye. It has an easy-to-clean, smooth surface with a durable and scratch-resistant coating.



No special cleaning products are required and both sides of the glass hold the same properties meaning either side can be placed towards the artwork. Clarity blocks up to 70% of ultraviolet (UV) light rays which is better than normal glass, but it does not meet full conservation standards for UV light protection.

Supplied in protective cartons.

Thickness: 2mm

Product code	Description	Thickness mm	Size mm	Size inches
CLA 080 110	6 Sheets	2	800 x 1100	31½ x 43¼
CLA 110 160	4 Sheets	2	1100 x 1600	43¼ x 62¾
CLA RIT 013	Framed Picture			
CLA BLJ 015	Specifier			
CLA BLJ 017	Frame Label			

Museum Glass® Tru Vue® Glass

Conservation-Grade UV Protection Glass.

Conservation Clear® meets ISO 18902 and passes ISO 18916.

Blocks up to 99% of UV light rays with over 89% light transmission and 8% light reflection. Supplied in protective cartons.

Thickness: 2.5mm

Product code	Dimensions mm	Dimensions inches	Pack qty
BDTVMG2501	1220 x 915 x 2.5	48½ x 36½ x ¼	3 sheets



Image with Museum Glass®



Image without Museum Glass®

Tru Vue® Premium Glass Cleaner®

Ideal picture framing glass cleaner. With conservation in mind it is ammonia-free. For superior presentation it is soap-free, and non-streaking. The static-free, de-ionised formula repels dust. The 620ml trigger spray plastic bottle, is ozone-friendly.



Glass-cleaning tips:

- Always use an ammonia-free cleaner
- Always use a soft lint-free cloth to clean the glass
- Spray your cleaner onto the cloth, not directly onto the glass

Product code	Description	Pack qty
SUTRCL0001	Tru Vue® premium glass cleaner	1

AR Reflection-Free® Tru Vue® Glass

The same amazing clarity as Conservation Clear® and Museum Glass® but does not provide Conservation-grade UV protection. It allows over 97% light transmission and reduces reflections to less than 1%. It blocks up to 78% of UV light rays.

Supplied in protective cartons.

Thickness: 2.5mm

Product code	Thickness mm	Size mm	Size inches	Description
BDTVRF0122	2.5	910 x 1220	35¾ x 48½	2 sheets



Image with AR Reflection-Free®



Image without AR Reflection-Free®

Conservation Clear® Tru Vue® Glass

Conservation-grade UV Protection Glass. Conservation Clear® meets ISO 18902 and passes ISO 18916. Blocks up to 99% of UV lights rays with over 89% light transmission and 8% light reflection.

Supplied in protective cartons.

Thickness: 2.5mm

Product code	Size mm	Size inches	Pack qty
BDTVCC2501	1220 x 915 x 2.5	48 ¹ / ₂ x 36 ¹ / ₂ x ³ / ₂	4 sheets
BDTVCC2502	1525 x 1015 x 2.5	60 ³ / ₄ x 36 ¹ / ₂ x ³ / ₂	2 sheets
BDTVOM0001	Sample kit		

Tru Vue® Optium® Museum Acrylic - Conservation-grade UV Protection

Durable and strong, 50% lighter than glass. Optium® Museum Acrylic is produced using a patented Tru Vue® technology. A magnetron-sputtered, anti-reflective, anti-static coating is bonded to an abrasion-resistant, UV-filtering acrylic sheet at an atomic level. This ensures long-lasting protection that doesn't oxidise and degrade over time. Optium® Museum Acrylic meets ISO 18902 and passes ISO 18916 by blocking at least 97% and up to 99% of ultraviolet light energy.

Sample box is available on request for a fee that will be refunded following an order.

Product code	Size mm	Size inches	Thickness mm	Pack qty
BDTVOM7319	2440 x 1220	96 ¹ / ₈ x 48 ¹ / ₂	3	1 sheet
BDTVOM7410	1830 x 2440	72 ³ / ₄ x 96 ¹ / ₈	4.5	1 sheet
BDTVOM7618	1830 x 3048	72 ³ / ₄ x 10ft	6	1 sheet
BDTVOM0001	Sample kit			1



Image with Conservation Clear®



Image without Conservation Clear®



Image without Optium Museum Acrylic®



Sample kit

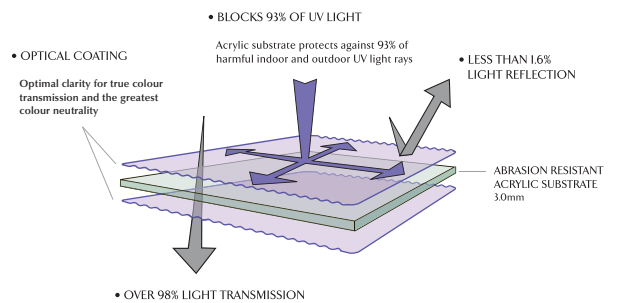

Negative no. 82134d. Collection of The New-York Historical Society

Cutting Equipment

Swann-Morton Scalpels

Non-sterile, carbon steel surgical blades, foil-packed in fives, boxed in 100s.

SUSMBL0003



SUSMBL0004



Linked Products: Steel Straight Edge p154.

Product code	Description	Pack qty
Handles		
SUSMBL0003	Swann-Morton Handles No.3	1
SUSMBL0004	Swann-Morton Handles No.4	1
SUSMBL0007	Swann-Morton Handles No.7	1
Blades		
SUSMBL0010	Swann-Morton Blades N°10	100
SUSMBL0011	Swann-Morton Blades N°11	100
SUSMBL0013	Swann-Morton Blades N°13	100
SUSMBL0015	Swann-Morton Blades N°15	100
SUSMBL0021	Swann-Morton Blades N°21	100
SUSMBL0022	Swann-Morton Blades N°22	100
SUSMBL0023	Swann-Morton Blades N°23	100
SUSMBL0024	Swann-Morton Blades N°24	100
SUSMBL0025	Swann-Morton Blades N°25	100
SUSMBL0027	Swann-Morton Blades N°27	100
SUSMBL1010	Swann-Morton Blades N°10A	100



SUSMBL0010 SUSMBL0011 SUSMBL0013 SUSMBL0015 SUSMBL0021 SUSMBL0022



SUSMBL0023 SUSMBL0024 SUSMBL0025 SUSMBL0027 SUSMBL1010

Snap off Blade Knives and Rotary Cutter

Japanese snap off blade knives and Excel Black blades for precise clean cuts; 9mm blades, 0.38mm wide and 18mm blades, 0.5mm wide. Blade disposal unit available to safely remove used blades.



Linked Products: Steel Straight Edge p154; Rotatrim p155.

Product code	Description	Compatible Blades
EQOLKN0001	X Design Comfort Grip Auto Lock Snap Knife 9mm	EQOLBL0101, EQOLBL0102
EQOLKN0101	Professional Pro-Load Multi Blade (5) Snap Knife 9mm	EQOLBL0101, EQOLBL0102
EQOLKN0102	Professional Pro-Load Multi Blade (6) Snap Knife 18mm	EQOLBL0001
EQOLKN0201	Comfort Grip Rotary Cutter 45mm	EQOLBL0201
EQOLBL0101	Excel Black Ultra Sharp Snap Blades (10 pack) 9mm	
EQOLBL0102	Excel Black Ultra Sharp Snap Blades (50 pack) 9mm	
EQOLBL0001	Excel Black Ultra Sharp Blades (50 pack) 18mm	
EQOLBL0201	Blades for Rotary Cutter (1 pack)	

Self-Healing PVC Cutting Mats

Self-healing PVC cutting mats provide a durable non-slip surface for repetitive cutting without mess or harm to the knife-edge or working surface.



Linked Products: Mount boards p113; Polyester Rolls p77.

Product code	Size/Colour	Size mm	Size inches	Pack qty
SUSHCM0001	A1 – Green/Blue, grid both sides	900 x 620 x 3	35 ⁷ / ₁₆ x 24 ³ / ₃₂ x 1/8	1
SUSHCM0002	A1 – Translucent	900 x 620 x 3	35 ⁷ / ₁₆ x 24 ³ / ₃₂ x 1/8	1
SUSHCM0003	A2 – Green/Blue, grid both sides	600 x 450 x 3	23 ³ / ₈ x 17 ³ / ₃₂ x 1/8	1
SUSHCM0004	A2 – Translucent	600 x 450 x 3	23 ³ / ₈ x 17 ³ / ₃₂ x 1/8	1
SUSHCM0005	A3 – Green/Blue, grid both sides	450 x 300 x 3	17 ³ / ₃₂ x 11 ³ / ₁₆ x 1/8	1
SUSHCM0006	A3 – Translucent	450 x 300 x 3	17 ³ / ₃₂ x 11 ³ / ₁₆ x 1/8	1
SUSHCM0007	A4 – Green/Blue, grid both sides	210 x 297 x 3	8 ¹ / ₄ x 11 ³ / ₁₆ x 1/8	1
SUSHCM3648	Green, grid both sides (metric and imp)	914 x 1219 x 3	35 ³ / ₆₄ x 1147 ³ / ₆₄ x 1/8	1
SUSHCM4080	Green, Plain (no grid)	1016 x 2032 x 3	40 x 80 x 1/8	1

Forged Steel Scissors

Hot-forged steel scissors, chrome-plated, with a screw used to adjust the blades.



Product code	Style	Length mm	Length inches	Pack qty
SUSCIS0001	A	115	4 ¹ / ₂	1
SUSCIS0002	B	170	6 ¹ / ₁₆	1
SUSCIS0003	C	215	8 ³ / ₃₂	1
SUSCIS0004	D	220	8 ⁷ / ₃₂	1

Scissors

Scissors blades made of hardened stainless steel and ergonomically designed ABS plastic handles.



Product code	Style	Length mm	Length inches	Pack qty
SUSCIS0005	A	140	5 ³ / ₆₄	1
SUSCIS0006	B	180	7 ¹ / ₃₂	1
SUSCIS0007	C	210	8 ¹ / ₆₄	1
SUSCIS0008	D	280	11 ¹ / ₃₂	1

4-Hole Punch

Metallic punch enables simultaneous punching of 4 Ø 6mm holes – standard spacing of 80mm. An indispensable tool that makes it possible to insert paper or polyester sheets into files and filing boxes with 4-ring mechanisms.



Product code	Description
EQPERF004	4 x 6mm diameter holes

Punch Kit

Kit of 15 punch sizes with handle to fit. Ideal for punching holes in paper, board, Plastazote® foam etc.



Product code	Description	Size mm	Size inches
EQPUK10015	Set includes 15 diameter pieces	3 - 30	1 ³ / ₁₆

Corner-Rounder

Hand-operated device with detachable heads for rounding off encapsulated polyester pockets and mountboards with up to 13mm (½") thickness cut capacity with the required radius. These come in two models, 'Standard' and 'Deluxe'. The 'Deluxe' will accept larger material and features a heavier-duty wooden table. Other cutting heads are available on request, please use the chart below which is to scale and contact CXD with your particular requirements.

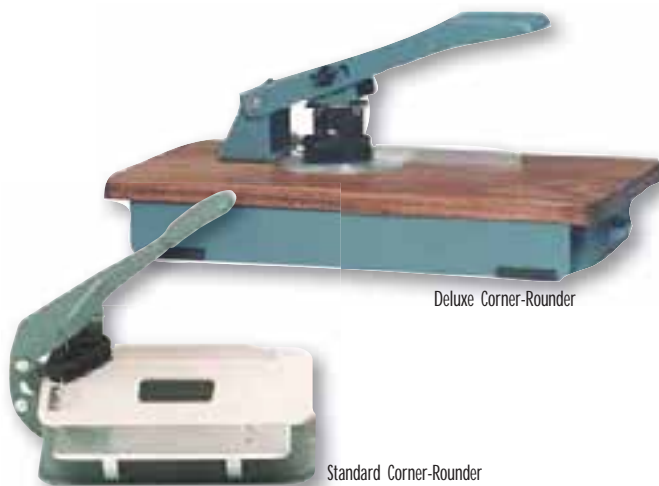

 *Linked Products: Box Boards p110; Mount Boards p113; Polyester Rolls p77; Curateur Welder p174.*

Product code	Model	Dimensions mm	Dimensions inches
EOCRHD5006	Deluxe	6	1/4
EOCRHD5009	Deluxe	10	3/8
EOCRHD5012	Deluxe	13	1/2
EOCROU0006	Standard	6	1/4
EOCROU0009	Standard	9	3/8
EOCROU0012	Standard	13	1/2
EOCRSB0006	Spare cutting head	6	1/4
EOCRSB0009	Spare cutting head	9	3/8
EOCRSB0012	Spare cutting head	13	1/2

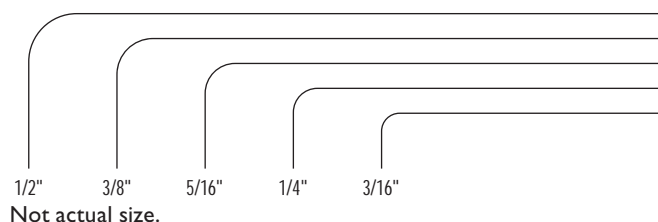

The Original Japanese Screw Punch

The authentic Japanese Screw Punch was first invented in 1977 and brought to our attention by Christopher Clarkson. In recent years there has been a raft of cheap imitations which, on close inspection, vary



greatly from the original design produced by My Kiichi Nonaka. This was witnessed at the 2012 Moulin du Verger 'Handmade Paper and Limp Paper Binding' summer school when an imitation punch purchased for the course would not work. There were significant differences but, on first sight, it was hard to tell the copy from the original. However, the punches we sell are marked on the ferrule with the text 'SCREW PUNCH MADE IN JAPAN'. Some are also modified by us to a design of Christopher Clarkson which allows the mechanism to be locked when making holes at an angle through several layers, an example being limp vellum bindings as featured in Christopher's book on the subject. This is not a feature found on the cheap imitation tools.

This tool was designed for making holes with controlled 'torque force' in a variety of materials. Downward pressure causes the bit to spin and drill down through a variety of materials quietly and smoothly and without blocking or snagging.

A great little hole-cutter that is quiet, fast and efficient at cutting through multiple layers of paper, card, leather and fabric.

The Screw Punch is supplied with a 3mm cutting bit as standard, which can be changed for any one of 10 further sizes, all fitting the same tool.

Cutting bits available in the following sizes:

1.0mm, 1.2mm, 1.5mm, 1.8mm, 2.0mm, 2.5mm, 3.0mm, 3.5mm, 4.0mm, 4.5mm, 5.0mm

Product code	Description	Description mm
EQSPSE3000	Japanese Screw Punch and 3mm bit	3.0
EQSPRB1000	Japanese Screw Punch bit	1.0
EQSPRB1200	Japanese Screw Punch bit	1.2
EQSPRB1500	Japanese Screw Punch bit	1.5
EQSPRB1800	Japanese Screw Punch bit	1.8
EQSPRB2000	Japanese Screw Punch bit	2.0
EQSPRB2500	Japanese Screw Punch bit	2.5
EQSPRB3500	Japanese Screw Punch bit	3.5
EQSPRB4000	Japanese Screw Punch bit	4.0
EQSPRB4500	Japanese Screw Punch bit	4.5
EQSPRB5000	Japanese Screw Punch bit	5.0



Maped™ Mat-Cutter System 80cm and 60cm

A complete multi-purpose cutting kit with adjustable stop system. For 45° and 90° cuts without preliminary marking. Includes a 45° and 90° cutting head, aluminium cut-true 800mm ruler with graduations and non-slip backing. Suitable for right and left-handed users.

Product code	Rule length mm	Rule length inches	Pack qty
EOMMCU0080	800	31½	1
EOMMCU0060	600	23¾	1



Maped™ Cutting Heads

Cutting heads linked to the Profila or Quadra ruler, the cutter head slides into the groove of the ruler. It enables straight 90° cuts or 45° bevel cuts for window mounts.

Product code	Description	Pack qty
EOREBL4510	Pack of 10 replacement blades for CS45	1
EOREBL9010	Pack of 10 replacement blades for CS90	1
EOMCSY4590	Set of 2 cutters 45° and 90° Degree	1
EOMCSY0045	45° cutter	1
EOMCSY0090	90° cutter	1

Maped™ Rulers – Profila

Profila Maped™ ruler in anodised aluminium with stainless cutting edge. Can be used with Maped™ cutting heads. Profila is a professional ruler adapted to 3 functions: measuring, cutting and ruling.

Perfect adhesion to the support because of anti-slip system near the cutting edge.

Exceptionally stiff and easy to hold.

EQMPRN0100



Linked Products: Snap off Knives and Scalpels p151; Self Healing Cutting Mats p151; Boards p98-104.

Product code	Length mm	Length inches	Pack qty
EQMPRN0060	600	23 ⁵ / ₈	1
EQMPRN0080	800	31 ¹ / ₂	1
EQMPRN0100	1000	39 ³ / ₈	1
EQMPRN0120	1200	47 ¹ / ₄	1

Maped™ Rulers – Quadra

A straight edge which can also be used with Maped™ cutting heads. Features stainless steel cutting edge, anti-slip system near the cutting edge and extruded full-length ergonomic handle providing a good grip along its length and greater safety while cutting.

EQMQRN0100



Linked Products: Mountboard p113; Millboard p112; Folding Boxboard p110.

Product code	Length mm	Length inches	Pack qty
EQMQRN0080	800	31 ¹ / ₂	1
EQMQRN0100	1000	39 ³ / ₈	1

Maped™ Rulers – Prodeca

A heavy 895g straight edge which can be used alone or with the Quadra 80 to give it extra weight.

EQMQWN0080



Linked Products: Mountboard p113; Millboard p112; Folding Boxboard p110.

Product code	Description	Pack qty
EQMQWN0080	For use with Quadra 80cm rule	1

Steel Straight Edge

This new range of precision, non-slip, ultra-safe straight edges will prove indispensable in any busy finishing area. The profiled aluminium safety rail is bonded to a straight, 3mm thick steel guide edge, enabling precise, vertical cuts using hand-held knives or scalpels – without slicing off your fingers!



Linked Products:

Snap off Knives and Scalpels p151; Self Healing Cutting Mats p151; Boards p98-104.

Product code	Length mm	Length inches	Pack qty
EQRTSE1200	1200	47 ¹ / ₄	1
EQRTSE1800	1800	70 ⁵ / ₆₄	1
EQRTSE2600	2600	8ft 6 ³ / ₆₄	1

Micrometers

A selection of different throat-size digital and dial micrometers – all with feelers that are designed for use with soft leather, cardboard, paper and foils.

J50 thickness gauge with lifting device

J200 thickness gauge with lifting device

J200 available with optional stand

J50 thickness gauge with lifting device



Linked Products: Mountboard p113; Millboard p112; Folding Boxboard p110.

Product code	Description	Reading mm	Range mm	Depth of jaw mm
EQMDIA0067	J50	0.10	10	50
EQMDIA0017	J200	0.10	10	200



© Photo: Christian Tchong

Ideal 0135 and 0155

Two large-format manual rotary trimmers with professional features; slotted side brackets for cutting oversized formats (unlimited cutting length).

Suitable for cutting and trimming of...

- Blueprints
- Paper and foils
- Drawings
- Plans
- Photos
- Posters or similar large-format digital

Smooth-running safety cutting head with self-sharpening rotary blade made from special hardened steel. Counter blade made of stainless knife steel. Automatic clamping system with transparent clamp bar.

Practical collection tray for trimmings. Complete with sturdy metal stand.

Convenient paper roll holder available as an option (at an extra cost).

Ideal 0135:

- Dimensions (W x D x H): 1540 x 480 x 940mm
- Table height: 865mm
- Cutting length: 1350mm, Cutting height: 0.8mm
- Max. weight 32kg

Product code	Description	Cutting length mm	Cutting length inches
EQIDEA0135	Model: Ideal 0135	1350	53 ³ / ₃₂
EQIDRD0135	Roll Dispenser for Ideal 0135		

Ideal 0155:

- Dimensions (W x D x H): 1740 x 480 x 940mm
- Table height: 865mm
- Cutting length: 1550mm, Cutting height: 0.8mm
- Max. weight 35kg



Product code	Description	Cutting length mm	Cutting length inches
EQIDEA0135	Model: Ideal 0155	1550	61 ¹ / ₃₂
EQIDRD0155	Roll Dispenser For Ideal 0155		

 **Linked Products:** Timecare® Polyester Rolls and Cut Sheets p77-78.



Rotatrim Professional M Series

Vital to the performance of every rotary trimmer is the accuracy of its 'shear point', the exact contact point between the rotary and flat (counter) blades at which the cut occurs. It is only by ensuring that the 'shear point' is as perfect and consistent as possible that a truly precise cut can be achieved.

The rotary blade is ground twice and deflashed to remove any burring. This results in a truly self-sharpening blade, which is long-lasting and maintains unrivalled levels of precision over its lifetime. The self-sharpening rotary blades will wear over time, though you should expect 10 – 15 life-years under normal use, while the counter blade is designed to last the lifetime of the machine.

A proven range designed and evolved from the demanding photographic industry over the past 40 years, which is available in ISO+ sizes to give greater flexibility. The blades for these machines have been fashioned from hardened Sheffield Tungsten Steel, which can be manufactured to extremely tight tolerances while offering excellent longevity.



 **Linked Products:** Snap off Knives and Scalpels p151; Self Healing Cutting Mats p151; Boards p98-104. Polyester.

Suitable for cutting...

- Polyester
- Tissue paper
- Felt
- Digital prints
- Card
- Self-adhesive film
- Foil
- Posters

Product code	Model	Size guide	Cut length mm	Cut length inches	Cut capacity mm	Weight kg
EORTCM0020	M20	A3+	508	20	3.0	6.5
EORT_M0030	M30	A2+	763	30 ³ / ₆₄	3.0	8.5
EORT_M0036	M36	A1+	914	35 ⁹ / ₆₄	2.0	8.9
EORT_M0042	M42	A1+	1068	42 ³ / ₆₄	1.5	10.5
EORT_M0054	M54	A0+	1374	54 ³ / ₃₂	1.5	12

*To order the machine alone insert 'C'. For the Kit, which includes Machine, Stand and Waste-catcher, insert 'K' into the product code.

Rotatrim Technical Series

All models in the Technical range will slice effortlessly through almost any flexible sheet up to 4mm thick. Additionally, these versatile cutters are equally at home with thin films and foils due to the unique, self-adjusting, triple-roller, cutting-head and blade made from self-sharpening tungsten steel.



Product code	Size guide	Cut length mm	Cut length inches	Cut capacity mm	Cut capacity inches	Weight kg
EQRT_T0650	A2	508	20	4	5/32	9.4
EQRT_T1250	A0	763	30 3/64	4	5/32	13.8
EQRT_T1550	A0	914	35 63/64	4	5/32	16
EQRT_T1850	2A0	1068	42 3/64	4	5/32	18.1
EQRT_T2500	4A0	1374	54 3/32	4	5/32	23

*To order the machine alone insert 'C'. For the Kit, which includes Machine, Stand and Waste-catcher, insert 'K' into the product code.

Keencut Simplex™ Large-Format Cutter

The innovative design of Keencut Simplex™ offers exact accuracy for general-purpose cutting of wide-format materials up to 3.1m wide. Keencut Simplex™ features a straightness guarantee of 1.00mm, or 1:3000 over the length of the cutter bar, Keencut Simplex™ is an economical alternative to the Keencut Javelin where less extreme accuracy is required. Keencut Simplex™ is lightweight, portable, and perfect for cutting PVC foamboard, vinyl, woven fabrics, foam-centred board, honeycomb and corrugated plastics, film, paper, tissue and many more flexible and rigid display materials.

The Keencut Simplex™ uses utility knife blades and features blade-depth adjustment and a spring-loaded blade ejector as standard. The utility blades will cut to a depth of 10mm (0.4"). The patented linear bearings have been tested under load for 1600km (1000 miles) and carry a 20-year guarantee. Full-length silicon rubber grip strips ensure all work is clamped when cutting and also protect the surface of the material being cut.



Product code	Description	Cutting length mm	Cutting length inches	Pack qty
EQKSLF0160	Usable Length 160cm	1600	62 9/64	1
EQKSLF0210	Usable Length 210cm	2100	82 9/64	1
EQKSBL0019	Medium Duty Utility Blades			100
EQKSBL0027	XR Blades, for Extra-deep cutting blades in black			100

Rotatrim PowerTech Series

These models have the cutting head electrically driven by a steel-reinforced belt, via a foot-operated pneumatic switch, thus leaving both hands free for speedy repositioning and faster throughput.

The products have guide rails manufactured from 1 1/2" square stainless steel and a cutting-head that utilises the self-sharpening tungsten steel blades to eliminate distortion. The aluminium baseboard is strong, warp-free and features parallel indents and satin finish. Longer machines (over 1550mm) are supplied with unique extension rods that will effectively double the baseboard depth to 700mm.

With the range of both the Technical and PowerTech Series extending to a massive 2500mm (99") cut length, these machines are perfect for display/exhibition applications, finishing of all digital media and fast, accurate, dead-straight trimming of pop-ups, encapsulated posters, vinyls and banners.



Product code	Size guide	Cut length mm	Cut length inches	Cut capacity mm	Weight kg
EQRTPT0950	A1	950	37 1/32	3	51.7
EQRTPT1550	A0	1550	61 1/32	3	57.7
EQRTPT1850	2A0	1850	72 3/64	3	60.7
EQRTPT2500	4A0	2500	98 7/64	1.5	57.2

Rotatrim FoamTech Series

A completely redesigned head mechanism allows corrugated and foamboard up to 5mm to be cut accurately in a single pass, without noticeable distortion to either side of the material. The large-format sizes have been selected to suit CXD corrugated board, though these machines are able to cut virtually the same materials as the Technical Series.



Product code	Size guide	Cut length mm	Cut length inches	Cut capacity mm	Cut capacity inches	Weight kg
EQRTFT0950	A1	950	37 1/32	5	1 9/64	11.2
EQRTFT1550	A0	1550	61 1/32	5	1 9/64	15.8
EQRTFT1850	2A0	1850	72 3/64	5	1 9/64	18.1
EQRTFT2500	4A0	2500	98 7/64	5	1 9/64	23.1

Studio Board Shear

The machine has a high precision ground upper and lower blade that allows the operator to perform precision cuts up to 1100mm with little effort on paper stacks up to 4mm (approx. 10 sheets of 70gsm and 8 of 80gsm paper). Safety features include automatic safety guard and metal guard plate as well as ergonomically shaped carrying handles and recessed grips.

Product code	Cut length mm	Cut capacity mm	Cut capacity inches	Weight kg
EQWOGU0585	1100	4	5/32	78

Ideal Office Trimmer for A3/A4 - Automatic Clamp

Automatic clamp for precise and convenient cutting. 'Easy-Lift', the innovative release lever lifting the automatic clamp for easy removal of paper. Large cutting table with a solid all-metal construction.

- Re-sharpenable, high-quality blade set made of 'Solingen Steel'.
- Solid cast aluminium blade mounting bracket with double pivot bearings for blade axle.
- Transparent safety guard with integrated cutting line indicator for exact alignment of the material to be cut.
- Precision metal side lay and adjustable back gauge. Measuring scale in mm/inches.
- Standard paper sizes from A6 to A3, American letter size and various angle indications printed on the table. Non-skid rubber feet for safe operation.
- Attractive, functional design. Quality product 'Made in Germany'.
- Safety-tested by independent safety labs.

EQIDTR1135



Product code	Model	Size guide	Cutting length mm	Cutting length Inches	Cut capacity mm
EQIDTR1135	1135	A4	350	13 ⁵ / ₃₂	25 sheets (70gsm)
EQIDTR1046	1046	A3	460	18 ¹ / ₆₄	30 sheets (70gsm)

Heavy-Duty Paper Block Cutting Guillotine

All heavy-duty guillotines provide accurate cuts in large stacks of sheet material with capacity from 20-80mm and come with 5-year manufacturer's warranties, excluding wear parts. The cutter tables are constructed of metal, have a ground upper blade made of Solingen Steel, a backstop, a transparent safety cover and a scale-bar marked out with mm, inches and DIN formats pre-printed on the table.

The 858 and 852 models feature a unique design allowing pressing and cutting in a single pass, front operation for maximum transmission of power, laser beam indication of cutting line and electronic display for each and any work step.

The 846 and 842 for precision-sizing of large paper stacks both feature a ground upper blade, quick-action clamping, visualised cutting line, back-stop side 430 x 430mm and off-cut side 430 x 215mm.

The 846 also has a plexiglass safety cover and a spindle-driven, self-locking back-stop set with calibrated crank handle for greater accuracy and cut capacity.



EQHDCU0852



EQHDCU0842

Product code	Cut length mm	Cut capacity mm
EQHDCU0842	430	20
EQHDCU0846	430	60
EQHDCU0852	435	20
EQHDCU0858	475	80
EQHDCS0752	Stand for EQHDCU0852	
EQHDCS0758	Stand for EQHDCU0858	

EQHDCU0858

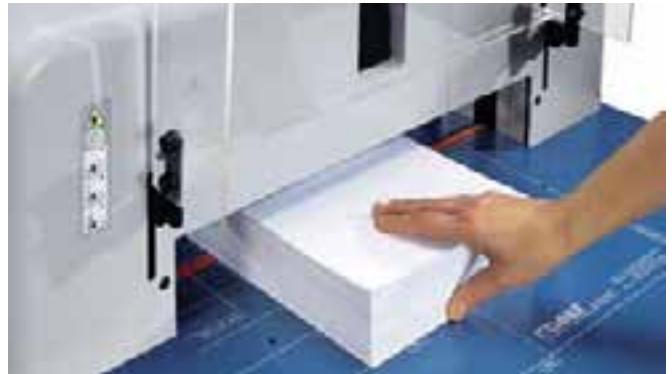

EQHDCU0846



Schimanek Heavy-Duty Guillotine

The highest quality paper-stack and board-sizing machines CXD offer, with tables constructed of either 3mm sheet steel or solid cast iron. The diverse range includes two floor standing Type 10 (cast iron), two floor standing Type 15 (sheet steel) and Types 70 and 85 tabletop versions both with solid cast iron tables plus optional stand and foot-press.

All machines feature a front stop, registering straight edge with fitted sliding angle guide, adjustable lower blade and scales in mm. For safety purposes a Plexiglass blade-guard is also fitted. Stands are available for Types 70 and 85.

Type 10



Type 15



Type 75/80
With optional stand
and footpedal



 *Linked Products: Mount board p100; Superior Millboard p112.*

Product code	Model	Table length mm	Cut width mm	Cut width inches	Weight kg
EQSFCG1172	Type 10	720	1100	42 ⁵ / ₁₆	360
EQSFCG1272	Type 10	720	1200	47 ¹ / ₄	370
EQSFSG1280	Type 15	800	1200	47 ¹ / ₄	290
EQSFSG1180	Type 15	800	1100	42 ⁵ / ₁₆	250
EQSTTG7000	Type 70		700	27 ⁷ / ₁₆	140
EQSTTG8500	Type 85		850	33 ¹⁵ / ₃₂	580
EQSFPG0850	Foot press for Type 70 and 85				
EQSFSG0850	Stand for Type 75/80				

7 in 1 Bookbinding Table

This new improved and beautifully made version of the bookbinding press, combines even more functions in one multi-functional machine by virtue of its ingenious design. Its singular, innovative design allows the press element to rotate, effortlessly, from the horizontal to the vertical position or even a full 180° degree rotation thus offering an alternative work surface. It is constructed totally by hand from beech wood and stainless steel elements, as well as other chrome parts which can be easily removed to enhance its functionality while reducing its space requirements. It also offers a curved knife for cutting large-size materials which is designed in such manner as to offer complete safety in all phases of the cutting process.

7 functions in one machine:

1 Lying Press 2 Sewing Frame 3 Plough 4 Paper and Board Cutter 5 Finishing Press 6 Standing Press 7 Working Table

1 Lying Press



2 Sewing Frame



3 Plough



4 Paper and Board Cutter



5 Finishing Press



6 Standing Press



7 Working Table



Product code	Description
EQOLBP7000	7 in 1 Bookbinding table

Professional Trimmer Ideal - Manual Clamp

Designed for professional use.

- Re-sharpenable, high-quality blade set, made of solingen steel.
- Solid manual clamp for variable pressure.
- Precision side lay with measuring scale (mm/inches) and adjustable back gauge.
- Lockable front gauge with integrated narrow strip device for cutting strips as narrow as 1mm.
- The front gauge is adjustable via a calibrated rotary knob.
- Fold-away paper supports on front gauge. Standard paper sizes indicated on the table. Automatic safety guard made from transparent, unbreakable plastic material, guard rises and falls with the movement of the blade.
- Solid cast aluminium blade mounting bracket with double-pivot bearings for blade axle.
- Solid all-metal construction.



Cutting length 580mm, Dimensions (H x W x D): 260 x 410 x 790mm, Weight: 14kg

Product code	Model	Cutting length mm	Cutting length inches	Cut capacity mm
EQIPTR1058	1058	580	22 ⁵³ / ₆₄	40 sheets (70gsm)
EQIPTR1071	1071	710	27 ⁶¹ / ₆₄	40 sheets (70gsm)

Keencut Ultimat Gold™ Mat-Cutting Machine

A professional cutting machine. Many years of experience and design have gone into making this the most highly developed machine of its kind. It can cut a 45° bevel in mat board more than 3mm thick. Numerous optional extras are available.

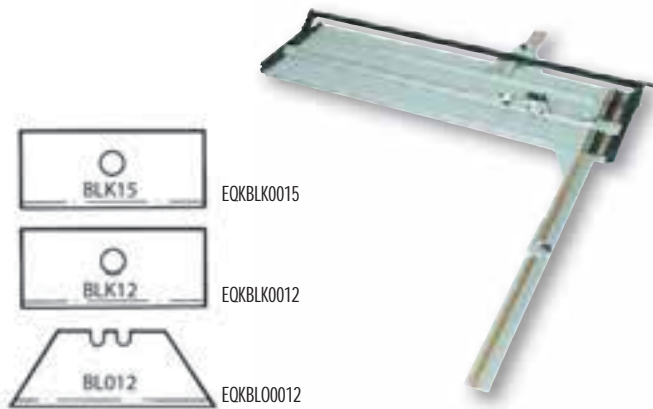

 *Linked Products: Mount board p74, p109, p113-114.*

Product code	Description	Size mm	Size inches	Pack qty
EQKUGM1200	Mount Cutter	1200	47 ¹ / ₄	1
EQKBLO0012	Trapezoidal Blades without Notches			100
EQKBLK0012	Rectangular Blades for Standard Board Types			100
EQKBLK0015	Rectangular Blades for Standard Board Types			100
EQKBRA0060	Set of Supporting Arms	Length 60cm	23 ³ / ₈	1
EQGUID0075	Guide Extension Kit	Length 75cm	29 ¹ / ₂	1

Large-Format Professional Trimmers with Stand

Re-sharpenable, high-quality blade set made of solingen steel. Standard equipment includes a sturdy stand and foot pedal clamping. Collapsible extension table (on the right side). Side lay with measuring scale in mm/inches. Back gauge and front gauge (the latter with integrated narrow strip-cutting device for cutting strips as narrow as 1mm). The front gauge is adjustable via a rotary knob with fine adjustment scale. Standard paper sizes indicated on the table. Stationary blade guard made from transparent, unbreakable plastic material and blade-locking device. Solid cast aluminium blade mounting bracket and sturdy blade axle with double bearing for precise cuts. Solid metal construction.

Dimensions (H x W x D): 1360 x 830/10603 x 1390mm.

Weight: 60kg

Cutting length 1100mm, pointed (25°) blade 1 as standard equipment— obtuse-angled (75°), blade 2 available upon request.



Keencut Ultimat Gold™

Product code	Model	Cutting length mm	Cutting length inches	Cut capacity mm
EQIPTSO800	IDEAL 80	800	31 ¹ / ₂	20 sheets (70gsm)
EQIPTSI1100	IDEAL 110	1100	42 ³ / ₈	20 sheets (70gsm)

Smart Mat Vertical Mount/Mat-Cutting System

A development of the first XY mount-cutter, wall-mounted to allow workshop space to be utilised to its maximum potential, not taking up precious and useful worktop space. Smart mat-cutters are made with rigid, stable tracks and operate with a ball bearing system on hardened steel rollers to ensure smooth, consistent movement. Will cut a true 45 degrees bevel from the back that will rival any other machine.

Both special sizes and an upgrade kit are available on request to convert an existing manual/pneumatic Smart Mat Cutter to a fully automatic machine, please contact CXD for more details.

 [Linked Products: Mount board p113.](#)

Smart Pneumatic Mount/Mat-Cutter

Wall-mounted, manual mount-cutter with heavy-duty tracks and industrial ball bearing system, pneumatic automatic rotating knife head and pneumatic clamp system, 4 production stops, 100 knife blades and steel brackets for wall-mounting. The clamp will allow the operator to cut a minimum border of 25mm.



Smart Pneumatic

Floor stand is available as an option.

Product code	Size cm	Size inches
EQSMPC0812	85 x 120	33 ¹ / ₂ x 47 ¹ / ₄
EQSMPC1218	120 x 180	47 ¹ / ₄ x 70 ⁵ / ₆₄
EQSMPC1624	164 x 245	64 ⁷ / ₁₆ x 96 ²⁹ / ₆₄

Smart Manual Mount/Mat-Cutter

Manual machine with heavy-duty tracks and industrial ball bearing system, manual knife head and manual clamp system.

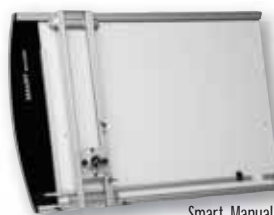

Smart Manual

Includes: 4 production stops, 100 knife blades and steel brackets for wall-mounting.

Product code	Size cm	Size inches
EQSMMC0812	85 x 120	33 ¹ / ₂ x 47 ¹ / ₄
EQSMMC1012	100 x 120	39 ³ / ₈ x 47 ¹ / ₄
EQSMMC1015	100 x 150	39 ³ / ₈ x 59 ¹ / ₁₆
EQSMMC1217	119 x 168	46 ⁷ / ₃₂ x 6 ²⁹ / ₆₄



Smart CMC Mount/Mat-Cutter

A complete computerised machine for cutting standard mats such as: rectangle, oval/circle, v-grooves and multi-openings. The Smart CMC is complete with floor stand, software and 100 production blades. For those who do not require the full functionality, such as only rectangular openings, this table is also available with more limited cutting options.



Smart CMC



Automatic knifehead

Manual knifehead



Smart Glass-Sizer

A Smart Glass-Sizer is also available, contact CXD for details.

Rectangular

Product code	Size cm	Size inches
EQSMR1015	100 x 150	39 ³ / ₈ x 59 ¹ / ₁₆
EQSMR1020	100 x 120	39 ³ / ₈ x 47 ¹ / ₄

Rectangular and oval

Product code	Size cm	Size inches
EQSMRO1015	100 x 150	39 ³ / ₈ x 59 ¹ / ₁₆
EQSMRO1216	120 x 160	47 ¹ / ₄ x 62 ²⁹ / ₆₄
EQSMRO1218	120 x 180	47 ¹ / ₄ x 70 ⁵ / ₆₄

Hot Knife

CXD heavy-duty Hot Knives are designed to cut and seal a variety of heat-sensitive foams, fabrics and plastics but are also ideal for the easy cutting and shaping of Plastazote® foam. The Hot Knife control unit and blade handle with variable temperature control can be used free-hand or with the aid of a template to give accurate, clean edges, which are free from loose particles. A variety of blades are available including a scooping-out wire that will prove useful for conservators wishing to create nests within the Plastazote® for housing archaeological and other delicate objects.

The separate control box and well-insulated handle remains cooler to touch than combined types.

Please take care when using this machine near smoke alarms as they may be activated should any smoke or fumes be given off during normal operation.



T3 blade, cutting Plastazote® foam

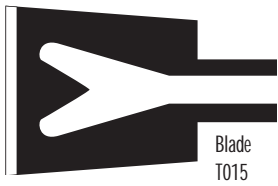

Linked Products: Plastazote® Foam p120; Channel Panel p120; Hot Air Gun p164.

Product code	Description	Model	Size mm	Size inches
EQHKHK0001	Standard model	240V		
EQHOTK7002	Low-voltage model	110V		
EQHKBL6608	Spade-shaped	T015/0.6	30	1 3/16

Thermocutter

The ZTS-20 Thermocutter is an electric cutter with heated blades. It easily and precisely cuts synthetic foam, polystyrene, polyethylene Plastazote® and Ethafoam®. Different blades enable the cutting of various forms. For example, it is possible to make cavities in foams to protect and nest objects.

Linked Products: Plastazote® Foam p120; Channel Panel p120; Hot Air Gun p164.

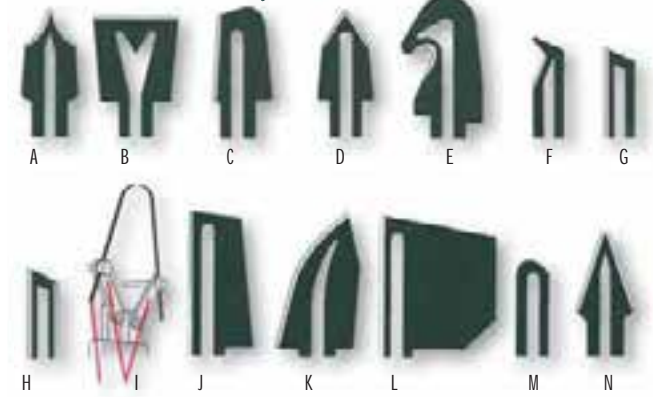

	Produce Code	Description
	EQHKHK0002	Hot Knife ZTS20
A	EQHKBL6622	Hot Knife Blade 10mm
B	EQHKBL6608	Hot Knife Blade 30mm
C	EQHKBL6620	Hot Knife Blade 40mm
D	EQHKBL6617	Hot Knife Blade 15mm
E	EQHKBL6619	Hot Knife Blade 6mm
E	EQHKBL6609	Knife Blade 12mm
F	EQHKBL6623	Hot Knife Blade 15mm
G	EQHKBL6611	Hot Knife Blade 15mm
G	EQHKBL6612	Hot Knife Blade 30mm
G	EQHKBL6613	Hot Knife Blade 50mm
G	EQHKBL3125	Hot Knife Blade 125mm
H	EQHKBL6628	Hot Knife Blade 50mm
H	EQHKBL6626	Hot Knife Blade 100mm
H	EQHKBL6627	Hot Knife Blade 150mm
I	EQHKBL0151	Hot knife cutting sling blade
I	EQHKBL6610	Cutting sling adjustable arms
J	EQHKBL6629	Hot Knife Blade 50mm
K	EQHKBL6625	Hot Knife Blade 45mm
L	EQHKBL6618	Hot Knife Blade 50mm
M	EQHKBL6621	Hot Knife Blade 10mm
N	EQHKBL6624	Hot Knife Blade 35mm

Repair and Conservation

Heated Spatulas - Spater 3

Equipment made in France, specially for conservation work:

- Temperature levels between 20 and 200°C
- Precise control by electronic regulation
- Digital display provides security, facility comfort in use.

Quickly reaches desired temperature and automatically compensates if the temperature drops while working on different surface temperatures, reaction of the system is instantaneous.

Easy-to-read tilted display.

Silicone cable is incombustible and anti-static.

 *Linked products: Heat set ArchiBond tissues. p105*



Applications

Conservation of paper, wood, paintings, textiles

Supplied with 4 different tips in chromed copper for good conductivity, a sponge basket for cleaning tips and a chrome steel stand for resting the iron when hot. (11.5 x 4.5 tip for heat-sealing is optional)

- Power supply: 220V
- Electronic regulation by thermocouple
- Power 35 W under 24V

Product code	Model
EQSPHS0003	Spater 3

Heated Spatulas - Spater 2 with Pre-Programmable Bits

Spatula with a temperature-control station on a digital display.

Range: 65 to 450°C. The set temperature when reached remains constant. It is controlled by a red diode.

Pre-programming of bits S1, S2, S3 and S6 for accurate temperature display. Silicone cable provides remarkable protection against burning due to accidental contact of the spatula on the cable. Supplied with a standard spatula S7.



 *Linked products: Heat set ArchiBond tissues. p105.*

	Produce Code	Description
	EQSPHS0002	Heated spatula + S7 tip
D	EQSHTI1000	Tip for Spater 2
C	EQSHTI2000	Tip for Spater 2
B	EQSHTI3000	Tip for Spater 2
A	EQSHTI4000	Tip for Spater 2
E	EQSHTI6000	Tip for Spater 2
F	EQSHTI7000	Tip for Spater 2
G	EQSHSU0001	Iron stand

Heated Spatulas - Spater 8

Tacking iron designed for restoration, repair and finishing work using heat-activated lamination. A good unit, which provides an alternative solution where budgets will not allow for the added heating-precision provided by the Willard range. Made up of a 40W applicator iron ensuring a considerable temperature reserve, with interchangeable tips.



To increase the precision and quality of the work, Spater 8 can be connected to the power regulator which allows operation over a very wide range of temperatures from 0 to 250°C.

 *Linked products: Heat set ArchiBond tissues. p105.*

Specifications

- 230V – 40W tacking iron
- Wound heating element
- Stainless steel heating unit
- Thermoplastic handle
- Max. temperature 250 to 300°C depending on type of tip
- Microprocessor-controlled power regulator for all types of iron
- 230V – 20W to 400W
- 4 additional tips available

	Product Code	Description	Size mm
	EQSTSP0001	Heated spatula 40W + SMM tip	
	EQSTTI0002	Temperature regulator	
A	EQSTSG0001	Tip for Spater 3/8/10	94 x 50
B	EQSTSM0002	Tip for Spater 3/8/10	52 x 24
C	EQSTSP0003	Tip for Spater 3/8/10	32 x 16
D	EQSTST0004	Tip for Spater 3/8/10	23 x 12

Heated Spatulas - Model Spater 10

This professional iron is ideally suited to restoration work of furniture, paintings and all heat-sealed finishing. Voltage 100W, delivered trouble-free, 4 spatulas to be chosen from according to your needs (available as an optional extra). The temperature of the spatula can be adjusted using an RP500 regulator (optional extra) to suit the job being performed or just to save energy. The temperature is adjusted using a potentiometer, graduated from 1 to 10, in the middle of the spatula that controls the amount of power absorbed. The range goes from 30 to 300°C.



Caution: the SMM, SPM and STPM must be used in conjunction with the RP500 regulator in order to avoid overheating.

 *Linked products: Heat set ArchiBond tissues. p105*

Produce Code	Description	Description cm
EQSPA1010	Heated spatula 100W	
EQSTTI0002	Temperature regulator	
EQSTSG0001	Tip for Spater 3/8/10	94 x 50
EQSTSM0002	Tip for Spater 3/8/10	52 x 24
EQSTSP0003	Tip for Spater 3/8/10	32 x 16
EQSTST0004	Tip for Spater 3/8/10	23 x 12

Willard Heated Spatulas - Heated Spatulas and Lining Irons

The Willard system offers a proven and respected range of spatulas (also known as tacking irons) and lining irons, designed and manufactured to the highest standards to provide many years of reliable service. They are in use in leading professional conservation studios worldwide. All models feature electronic sensors to provide accurate and consistent temperature at the tip or across the sole plate.

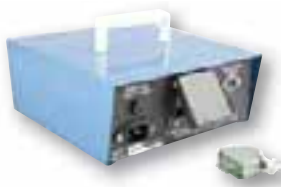

Control units

The control unit is the heart of the system and its unique design is capable of providing accurate and reliable service over many years. A control unit is needed to operate the spatulas and irons.

There are two models: Standard, to regulate spatulas only and Universal which regulates all spatulas and all irons. Both models will accept the separately available temperature display.

Standard

The standard control unit enables the temperature to be conveniently set on the display by adjusting the large control dial. It automatically switches full power to the heating element quickly on and off to provide an accurate temperature. A red diode illuminates when heat is being delivered to the tool.

Universal

The Universal Control Unit is required for lining irons; 6E, 7E, 8E and 9E. It is also suitable for all Willard heated spatulas. Temperature is set with the large dial on the front of the housing.

A wall-mounted variant, supplied complete with a built-in temperature monitor, is also available.

 *Linked products: Heat set BEVA adhesive and Film, ArchiBond tissues. p105.*

Product code	Description
EQWCUU0001	Control Unit Universal
EQWCUS0001	Control Unit Standard

IEC Heated Spatula with Tip Set

The durable and reliable IEC (Compact) with a set of 7 tips (below) is a highly popular and versatile hand tool system with a range of applications. It is fitted with a durable, wooden handle for comfortable use. Connection to the appropriate control unit is via kink and heat-resistant, silicone-coated flex.

Specifications

Length of spatula including tip: approx 75mm (6¾ inches)
Weight: approx 200g (6oz)

EQWHSS0002



1EC 7-piece tip set



Product code	Description
EQWHSS0002	Durable and reliable 1EC (Compact) with a set of 7 tips

IEM (Miniature) Heated Spatula

This pen-like model is the smallest of its type available, but has a comprehensive range of Mini and Micro-tips for a variety of precision applications. Connection to the appropriate control unit is via kink and heat-resistant, silicone-coated flex.

Fitted with any of the Mini-tips or silver Micro-tips, the right amount of heat can be applied with ultimate accuracy to a specific area, making this an ideal tool for tear-mending and many other tasks.

Specifications

Length: approx 133mm (5¼in) excluding tip
Weight: approx 75g (3oz)



EQWHSM0002

Product code	Description
EQWHSM0002	1EM Miniature Spatula

Micro-Tips to fit IEM Heated Spatula

This range of Sterling Silver Micro-tips has been specifically developed for use with the IEM. There are 5 different shapes and styles available, which can be supplied either individually, or as a complete set of 5 tips with an adaptor.



EQWMTS0005

Product code	Description
EQWMTS0005	Micro-Tips to fit 1EM Heated Spatula

4E Heated Spatula

The 4E Heated Spatula features a fixed, thin, curved sole plate with flanged edge.



EQWHST0004

 *Linked products: Heat-set BEVA adhesive and Film, ArchiBond tissues. p105 and p127.*

Specifications

Length: approx 220mm (8½ inches)
Weight: 0.4kg (7oz)
Sole plate area: approx 10.97cm² (1.7sq inches)
Sole plate length: approx 65mm (2½ inches)
Sole plate width: approx 24mm (1 inch)

Product code	Description
EQWHST0004	Heated Spatula 4E

Lining Irons

These units are connected to the purpose-built Universal Control Unit by kink-resistant flex. All Lining Irons are fully protected and feature electronic sensors in the sole plate to ensure accurate, even and consistent temperature across the sole plate.



 *Linked products: Heat set BEVA adhesive and Film, ArchiBond tissues. p105.*

Product code	Model/description	Size mm	Size inches
EQWLIL0007	Large 7E	270 x 170	10 5/8 x 6 7/16
EQWLIL0008	Large 8E	300 x 170	11 3/16 x 6 7/16
EQWLIL0009	Large 9E	285 x 140	11 1/32 x 5 39/64
EQWLIM0007	Medium 7E	230 x 140	9 1/16 x 5 33/64
EQWLIM0008	Medium 8E	270 x 140	10 5/8 x 5 33/64
EQWLIS0006	Standard 6E	200 x 115	7 7/8 x 4 17/32
EQWLIS0007	Standard 7E	200 x 140	7 7/8 x 5 33/64
EQWLIS0008	Standard 8E	270 x 170	10 5/8 x 6 11/32
EQWMLI0006	Mini 6E Symmetrical pointed-end Gothic-shape		
EQWMLI0007	Mini 7E Rectangular	150 x 75	5 29/32 x 2 81/64
EQWMLI0008	Mini 8E Rectangular inclined front edge		
EQWMTS0003	Mini-tips set of 3		
EQWMTS0005	Micro-tips set of 5		
EQHAGV0110	110V 5mm nozzle		
EQHAGV0240	240V 5mm nozzle		

Hot Air Gun

A high-powered industrial device useful for welding Plastazote® foam when making linings or complete boxes, which cannot be stuck with adhesives normally used in conservation. The application of heat on two surfaces softens them enough to be fused together on contact. Heat-activated adhesives can also be used. A selection of shaped nozzles are available for a variety of welding purposes.







The device is fully CE tested and reaches the required temperature within 3 minutes.

 *Linked Products: Plastazote foam p120.*

Specifications

Electronic switch for motor speed adjustment
 Regulated airflow between 3 and 350 litres per minute
 Temperature regulated between 2000°C and 6000°C
 Lightweight: 1.25kg (including 3m cord)

Product code	Description	
EQHAGN2240	40mm one-arm roller	
EQHAGN2805	Tacking Jet for spot-welding	
EQHAGN2940	40mm wide slot-nozzle	
EQHAGN3105	31G nozzle	
EQHAGV0110	Hot Air Gun 110V	5mm nozzle
EQHAGV0240	Hot Air Gun 240V	5mm nozzle

Dahlia Spray

Popular, precision-made, chrome-plated, Japanese fine mist watersprays for relaxing paper and other applications. Available in Medium and Large sizes.



Product code	Description	Capacity cc	Pack qty
SUDSL0980	Large	980	1
SUDSS0320	Medium	320	1
EODSL0001	Spare parts kits for Large Dahlia Spray		
EODSS0001	Spare parts kits for Small Dahlia Spray		

Steamy PR

The Micro Steam Generator, Steamy PR, is a precision tool designed to meet the needs of the paper conservator who demands a machine that is adjustable to give the choice of a fine or powerful stream of super-heated steam; for the removal of backings, adhesive tapes, mountings, etc., as well as for the local removal of stains and impurities on works of paper. The steam is fed through a 1.5m long heated tube and is produced for local treatment in a precise manner and without dripping. To avoid dripping and spitting, the required pressure is 3.5 bar. The steam temperature increases to approximately 160°C and thus prevents condensation of the water in the tube; the heating time is approximately 15 minutes. The ideal combination of quality and functionality makes this a dependable tool. Features include stainless steel housing, on/off switch, instant steam stand-by/shut-off lever, heated hose and optional flexi-stand for hands-free operation.



*For use only with decalcified water, see below for Steamy Delimer.

Product code	Description	Pack qty
EQSTPR7069	Micro Steam Generator	1

Delimer Water-Softening Device

This device produces a continuous supply of decalcified water to prevent lime-scale deposits in hard water areas that can cause damage and increase power consumption. Existing deposits of lime-scale will be dissolved continuously. The Delimer is being used as an intermediate unit for steam cleaners, hot water devices, cooling elements for instruments and appliances in medical technology, in laboratories and in production situations. Manual evacuation of water is possible by ordering a water tap as an optional extra.



Specifications

*Ion exchanger incl. automatic regeneration with softening salt
Semi-automatic regeneration process
Compact design*

Product code	Temp 0°C	Capacity litres	Dimensions mm	Dimensions inches	Weight kg
EQSTPR1000	N/A	2	190 x 340 x 290	7 ³¹ / ₆₄ x 13 ²⁵ / ₆₄ x 11 ²⁷ / ₆₄	7.5

ST Leafcasting Machine

Designed to provide conservators with an easy-to-use, fast-working high-quality leafcasting machine. It is the ideal machine for restoring graphics documents that have been partially damaged through chemical, biological or physical degradation. The merit of this machine resides in its specially-made pneumatic control function to avoid danger to the item being treated.



A smaller model is available for independent workshops.

Product code	Working dimensions (W x D) mm	Working dimensions (W x D) inches	External dimensions (L x W x H) mm	External dimensions (L x W x H) inches
EQMACG0001	750 x 650	29 ¹ / ₃₂ x 25 ¹ / ₃₂	1030 x 970 x 1060	40 ⁵ / ₆₄ x 38 ⁷ / ₁₆ x 41 ¹ / ₆₄

Preservation Pencil® and Ultrasonic Humidifier

The ultrasonic humidifier EQPPEN0004 is an indispensable complement to the Presentation Pencil®, but may be used on its own with hose and nozzle EQPPEN0003. In this case, the ultrasonic mist is cold.

Combined with ultrasonic humidifier UHI EQPPEN0004 and flexible hose EQPPEN0003, the Preservation Pencil® provides a fine, delicate jet of moist air from ambient to 100°C. Temperature settings remain constant and can be precisely controlled with the digital display.



EQPPEN0002



EQPPEN0004



EQPPEN0001

Applications

The Preservation Pencil® permits removing of documents from their support separating paper layers. It acts as emollient and cleaning agent. Once switched on, the unit is instantaneous and ready for use without condensation. The PP4 articulated support arm allows hands-free operation and can be fastened onto a table.

Product code	Description
EQPPEN0001	Preservation Pencil®
EQPPEN0002	Arm support for Preservation Pencil®
EQPPEN0003	Flexible hose for Preservation Pencil®
EQPPEN0004	Ultrasonic humidifier
EQPPEN0005	Ultrasonic humidifier and hose kit

P Series Paper Pulper

Designed especially for the disintegration of cellulose pulp to be used in leafcasting, this machine conforms to ISO standard 5264-2.

The machine frame is constructed from rectangular aluminium profiles on four shock-absorbing feet to create a solid base and frame to absorb vibration and keep noise to a minimum. Unlike alternative pulpers, fibres are not warmed-up in a grinding process nor are they cut as if in a blender but are separated by the shearing effect of the unique process. The unit is lightweight for easy handling and cleaning.

The pulper has been built with a container to hold 10-35 grams in 1000-3000ml and hinged so that it can be tilted for cleaning and easy removal of the leafcasting fibres. The unit incorporates safety cut-out devices.

Product code	Dimensions (L x W x H) mm	Dimensions (L x W x H) inches	Weight kg	Noise level dB
EQJZPD3240	320 x 400 x 700	12 ⁹ / ₃₂ x 15 ³ / ₄ x 27 ¹ / ₁₆	42	Less than 40



S Series Paper Pulper

Constructed using a powerful motor to drive the stainless steel blade spindle that is manually lowered into a sealed container with 5-litre capacity. An optional soundproofing cabinet is available.



Product code	Description	Dimensions (L x W x H) mm	Dimensions (L x W x H) inches	Weight kg
EQSTPD0001	DP2 Pulp Disintegrator	500 x 270 x 600	19 ¹ / ₁₆ x 10 ⁵ / ₈ x 23 ⁵ / ₈	35
EQSTPD0002	Cabinet for DP2 Pulp Disintegrator	525 x 450 x 1800	20 ⁹ / ₆₄ x 10 ⁵ / ₈ x 70 ⁵ / ₆₄	60

Multirestor®

This range has been designed to provide a number of functions within a single unit to avoid the need for multiple machines that take up precious space in conservation studios and workshops. All Multirestor® machines feature a strong suction device for leafcasting, sizing, laminating and for use as a vacuum table.

The tables can be tailored to perform a combination of functions to suit most conservation studio/workshop applications.

A selection of the functions are shown below; please contact CXD for further details.

E Series Paper Pulpers 2-litre

This device was designed for small restoration workshops for which it makes little sense to run large-scale production using a lot of pulp for working on filling machines. This fibre-extracting apparatus can be used to make all types of pulp and other product mixtures.

No particular electrical fittings are required.

This device is stainless steel and complies with the prevailing standards for preparing pulp for paper-making. The tank and support are made from PVC. The stainless steel wheel shaft and propeller are detachable so that the tank can be removed for pulp to be collected.



Specifications

Tank capacity: 2 litres

Dimensions in mm: 200 (width) x 300 (depth) x 750 (height)

Weight: 15kg

Product code	Dimensions (L x W x H) mm	Dimensions (L x W x H) inches	Weight kg
EQSTPD0013	300 x 200 x 750	11 ³ / ₁₆ x 7 ⁷ / ₈ x 29 ¹ / ₃₂	15



 **Linked Products:** Cotton Linters, Hand made Linen/Flax half stuff sheets. p91; P Series Paper Pulper p166.

Applications

Wet (in water) and dry (with water) leafcasting; spot leafcasting, sizing, de-acidification, washing, bleaching, rinsing, soaking, fixing, degreasing, dissolving, humidification, drying, disinfection, cleaning, stain or glue-removal, flattening of maps.

Product code	Description
EQJZMR0807	Multirestor® 3
EQJZMR1509	Multirestor® 6

Alan Buchanan Equipment

Illuminated Vacuum Table, high or low-pressure

The Vacuum Table surface is the size of an Imperial sheet of paper with a one-inch buffer added to each dimension (31 inches x 23 inches). Supplied with two vacuum pumps, an FPZ low-pressure regenerative blower of light construction, which creates a maximum vacuum of 275 millibars that will pass a maximum 400 litres per minute. The second is a Gast 1023 high-pressure, oil-free vane pump, providing up to 800 millibars moving a maximum of 200 litres per minute. The FPZ pump gives the initial seal and vacuum. If more vacuum is needed the Gast is turned on automatically. They work in conjunction up to a vacuum level of approximately 220 millibars, at which point the Gast takes over with the ability of lifting the vacuum to 800 or 850 millibars. Once the vacuum is over 220 millibars the FPZ pump is automatically turned off by a vacuum switch. Each pump is fitted with a non-return valve to ensure that one pump does not draw air through the other.

The work surface is made of sintered polyethylene which has a slight resistance to the passage of air, enough to distribute the level of vacuum evenly over the whole surface. The material is washable. The sintered polyethylene is carried on a PVC insert which is drilled and grooved, again, to ensure an even vacuum over the whole surface. Both are carried in a polypropylene tray.

The table also features an integral lightbox which is fitted beneath the vacuum table emitting 55W of light with a colour temperature of 4000 degrees Kelvin. Two small fans keep the compartment cool.



Linked Products: Synperonic A7 Solution p212.

Product code	Model	Model area (W x D) mm	Model area (W x D) inches	External dimensions (W x D x H) mm	External dimensions (W x D x H) inches
EQBIVT3123	Imperial Vacuum Table	787 x 584	30 ⁹ / ₆₄ x 22 ³ / ₆₄	860 x 660 x 914	33 ⁵ / ₆₄ x 25 ⁵ / ₆₄ x 35 ⁵ / ₆₄

Alan Buchanan Cedar Wood Humidification System



The cedar wood humidifying box is a closed chamber sitting on a non-porous surface with cedar wood sides and a polycarbonate lid. The box itself is formed by two 'L' shaped pieces for ease of handling and storage.

Cedar wood has useful properties; it's an insect repellent, suppresses mould and is highly porous.

A reservoir of water is provided inside the box by dampened capillary matting or fleece.

The object to be humidified can be placed on a screen over the reservoir or on a breathing membrane such as GoreTex® or one used in the building trade to go beneath the tiles to permit water vapour to escape.

The rate of humidification is slow, gentle and all-pervading because the cedar wood absorbs excess vapour.

Control of the rate of humidification is achieved by the amount of water sprayed onto the reservoir. The more water that is sprayed or dampening the cedar wood walls, the quicker the humidification. For very slow humidification the reservoir can be omitted and the external surface of the cedar wood can be repeatedly sprayed with water which will pass through the wall and will be absorbed by the object within the chamber.

Offered bespoke to any customer size required, please contact us for more information.

Reference; pp 276 277 Paper and Water by Gerhart Banik and Irene Bruckle ISBN-13:978-0-75066-831-6.

Buchanan High-Pressure Suction Point

A small-area, high-pressure machine ideal for the removal of pressure-sensitive adhesive tape and for stain removal. The suction point is let into the centre of a stainless steel surface of 770mm x 470mm (30" x 18"). The vacuum surface measures 100mm x 100mm and is of sintered polyethylene.

If required the whole stainless steel worktop can be lifted from the machine to stand in a fume cupboard or on a larger work surface. The vacuum pump will create a vacuum of up to 850 millibars or 85% of a pure vacuum. The pump is a Gast 1023 oil-free, rotary vane pump, 0.5 H.P. Single phase.

As with the larger Buchanan Vacuum table the 'Suction Point' incorporates an integral lightbox to assist in making an even-dyed pulp infill or for accurate repairs.

For further details please contact CXD.



Product code	Model	Model area (W x D) mm	Model area (W x D) inches	External dimensions (W x D x H) mm	External dimensions (W x D x H) inches
EQBDSP3018	Suction Point	100 x 100	3 ⁵ / ₁₆ x 3 ⁵ / ₁₆	770 x 470	30 ⁹ / ₆₄ x 18 ¹ / ₂

CXD Pneumatic Vacuum Tables

High or Low-Pressure Combination

A unique type of conservation vacuum table which is powered by compressed air. The CXD Pneumatic Vacuum Table with mobile support frame offers great flexibility and features a low-noise Hydrovane compressor with air reservoir which can be within the frame or external and remote for silent working. The vacuum is created by a venturi pump. Features include a large trap tank, filter, pressure regulators and low-pressure spray gun. Pneumatic vacuum tables have the advantage of good airflow combined with substantially higher maximum vacuum levels – 90% pneumatic compared to 22% on conventional electric low-pressure tables. The high vacuum pressure is ideal for stain removal because the solvent can be pulled through with greater force to prevent spreading. The pneumatic system does not rely on cooling air flow for the motor being pulled from above the object, therefore making it ideal for drying since the artwork can be covered to prevent dirt from the air being drawn through the artwork. The surface can be masked-off completely without fear of overheating. There is no electric motor for solvents to be pulled through thereby reducing the risk of fire. Liquids and solvents are gathered in a large trap tank/scrubber. The working surface is made of perforated stainless steel set in a sturdy aluminium frame. A variety of options are available including the humidification dome and humidistat. Special sizes and configurations are possible on request.



CXD Pneumatic Vacuum Table



Hydrostat

Low-pressure Spray Gun

Ultrasonic Humidifier

Linked Products: Professional Pulper p166;
Synporonic A7 Solution p212.

Applications

Rinsing, Washing, Bleaching, De-acidifying, Disinfecting, Water treatments, Drying, Flattening, Tape or Stain removal, Vellum and Parchment treatments, Lining, Sizing, Stretching, Paper-splitting, Spot-leafcasting

Options

- Electro-Mechanical Pump
- Humidification Dome and Humidistat
- Low-Pressure Spray Guns
- Ultrasonic Humidifier
- Satellite Tables
- Special sizes

Product code	Type	Working Dimensions mm	External Dimensions mm
EQVTC1308	Pneumatic with Integral Compressor	1300 x 800	1340 x 840 x 800
EQVTEC1308	Pneumatic with External Compressor	1300 x 800	1340 x 840 x 800

Belo – Illuminated Low-Pressure Table – Large-Format

Illuminated suction table for restoring paper and textiles. Micro-porous, rigid polyethylene plate. The 860 x 1000mm work surface is fully lit. The table is mounted onto an aluminium profile structure with 4 wheels fitted with brakes. Even lighting with brightness control. The lighting is located underneath the plate.



TASL by EQBELO0004

Low-pressure suction provided by WAP2 generator. A control box located at table level controls the brightness and the suction variation. Full table with connection pipes. Optional equipment: Transparent Acrylic Dome for which the table is pre-drilled in case the option is taken at a later date, Ultrasonic Humidifier, Electronic Humidity Regulation by sensor connected both to the humidifier and to the dome, the WAP2 generator can be replaced with the EQBELO0005/0006 generator.

With variable-control lighting for operator comfort and a variety of performance-boosting options, this flexible piece of equipment has a proven record with many prestigious clients.

Please try to specify options at time of order.



Product code	External size mm (and inches)	Working area size mm (and inches)
EQBELO0007	1500 x 1140 (59 x 44 7/8)	1430 x 1070 (56 1/4 x 42 1/8)
EQBELO0008	1800 x 1200 (70 7/8 x 47 3/4)	1730 x 1130 (68 1/8 x 44 1/2)

Other sizes are possible on request.

Specifications

- WAP2 generator: Low-pressure suction generator
- Rate of flow: 3600 l/min
- Power: 1200W
- Sound level: 62dB
- Mounted on 4 locking wheels
- Dimensions: 445 x 450 x 505mm (17 1/2 x 17 3/4 x 19 7/8 inches)
- Weight: 11kg

Product code	Description	Working dimensions
EQBELO0004	Belo Conservation Table with WAP2 generator	920 x 1060 x 950mm, working area size : 860 x 100mm
EQBELO0001	Acrylic Dome	
EQBELO0002	Humidity Regulator	
EQBELO0003	Ultrason Humidifier and Hose	
EQBELO0005	Vacuum for Belo Table 2 x 1200 W	
EQBELO0006	Vacuum for Belo Table 3 x 1200 W	

Bambi Compressor

We have selected Bambi Air Compressors because they are amongst the quietest compressors available and are manufactured to the highest standards. All units are individually tested and certified and different voltages are available on request. The compressors have thermal and electrical safeguards, with no exposed moving parts. The air receivers are manufactured in accordance with national standards. A filter and air regulator are fitted as standard.

Please contact CXD for more information.



BB24



BB24D

Product code	Description
EQACBB0024	Model BB24
EQACBB1024	Model BB24D
EQACBB0157	Option Wheel Kit

HC-5 Humidification Chamber

The heated HC-5 Humidification Chamber was developed in order that paper could be humidified in advance of working on suction tables etc. to avoid creasing and cockling. The HC-5 allows the controlled humidification of works on paper, particularly fragile items such as pastels, charcoal, watercolours etc.

For further technical information on this, please contact our sales department.



Product code	Description	Dimensions cm	Dimensions inches
EQHUHC0005		External 174 x 109 x 52	External 68.5 x 43 x 20.5
		Internal 157 x 103 x 34	Internal 62 x 40.5 x 13.5
		Working area 142 x 95	Working area 36 x 37.5
Hygrostat	Control range 30 – 95% RH, +/- 3%		
Potentiometer	For fan and ceiling heating elements		

ST Paper Press – Manual

Manually operated paper press. Metal construction, 60-micron epoxy-paint. Manual steering wheel. Plates protected by a PVC plastic-coating avoiding any oxidation.

Maximum pressure: 6000kg.

Available in 3 sizes:



Product code	Working dimensions (W x D) mm	Stroke mm	Stroke Inches	External dimensions (W x D x H) mm	External dimensions (W x D x H) inches	Weight kg
EQPRES5060	600 x 500	450	17 ¹ / ₂	700 x 510 x 1800	27 ¹ / ₁₆ x 20 ¹ / ₁₆ x 70 ³ / ₁₆	250/380 Packed
EQPRES6080	800 x 600	450	17 ¹ / ₂	900 x 610 x 1800	35 ¹ / ₁₆ x 24 ¹ / ₁₆ x 70 ³ / ₁₆	400/490 Packed
EQPRES8010	1000 x 800	450	17 ¹ / ₂	1200 x 810 x 1800	47 ¹ / ₁₆ x 31 ¹ / ₁₆ x 70 ³ / ₁₆	600/780 Packed

ST Paper Press - Electro-Hydraulic

Electro-hydraulic presses equipped with automatic pressure regulation. Metal structure, 60-micron epoxy-paint. Plates protected by a PVC plastic-coating avoiding any oxidation.

Maximum pressure: 9,000kg. Operation by hydraulic piston with digital pressure programmer. Available in 2 sizes:



Product code	Working dimensions (W x D) mm	Working dimensions (W x D) inches	Stroke mm	Stroke inches	External dimensions (W x D x H) mm	Weight kg
EQPREE6080	800 x 600	37 ³ / ₁₆ x 24 ¹ / ₁₆ x 59 ¹ / ₁₆	450		950 x 610 x 1500	535/750 Packed
EQPREE8010	1000 x 600	47 ¹ / ₁₆ x 31 ¹ / ₁₆ x 62 ³ / ₁₆	450		1210 x 810 x 1600	700/950 Packed

ST Paper Press – PR 36

A manual press of welded steel construction with anti-corrosion treatment and features oven-baked, polyester-coating.

- Usable dimensions: 500 x 400 x 300mm
- External dimensions: 500 x 400 x 700mm
- Maximum constant power: 200kg
- The platforms are protected with a PVC board to eliminate any oxidation
- Dimensions between platforms: 350mm
- Gross weight: 80kg with packaging
- Net weight: 60kg

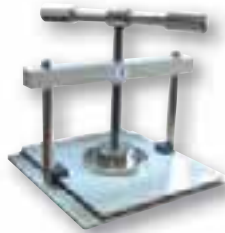

Product code	Working dimensions (W x D) mm	Working dimensions (W x D) inches	External dimensions (W x D x H) mm	Weight kg
EQPRES4060	400 x 600	350	500 x 400 x 300	60/80 Packed

Pneumatic Paper Press

Originally designed to simplify the pressing actions and replace the more cumbersome, traditional percussion or simple dead-weight presses, they were later developed to undertake a number of other pressing tasks. The simple operation means the machine does not need to be used exclusively by conservators. It is suitable for use with paper, textiles, vellum and leather.

The Pneumatic Paper Press frame is constructed from rigid, lightweight, aluminium profiles, supporting the pneumatic ram, which provides the press action. The attached heavy-duty press is lined with waterproof, laminated plywood. The advantages of a pneumatic system is that the pressure can be preset so the force exerted is consistent and requires no strength to operate, meaning almost anyone can use it.

If required, for further safety precaution, the unit can be enclosed on three sides with 5mm transparent polycarbonate, leaving only the front accessible to the operator. However the downward movement of the press requires that the operator use both hands to reduce the possibility of accidents.

Requires a compressor; please ask for a quotation.



Product code	Dimensions mm	Dimensions inches	Stroke mm	Stroke inches
EQJZPP1510	1500 x 1000	59 ⁵ / ₁₆ x 39 ³ / ₁₆	800	31 ¹ / ₂

Semi-Matic Laminators

Built using heated platens and manufactured to the highest standards for use by archivists and conservators, these units are capable of laminating a wide range of materials quickly and efficiently.

Both models have solid steel rollers and are wide enough for consolidation of laminate and automatic transfer to a receiving tray and solid state proportional temperature control adjustable from 0° to 130° allowing the use of a wide range of laminating materials including Archibond, B-Fix, Acetate etc. The SML2 platen can be set to open automatically based on the timer circuit or manually by two-handed button operation for safety reasons. The SML1 timer circuit can be utilised to sound a buzzer to alert the operator to open the platen manually.



SML1



SML2

Product code	Model	External dimensions (L x W x H) mm	External dimensions (L x W x H) inches	Platen dimensions (W x L) mm	Platen dimensions (W x L) inches
EQSMLL0001	SML1	1100 x 1000 x 1350	43 ⁵ / ₁₆ x 39 ³ / ₁₆ x 53 ⁵ / ₁₆	610 x 670	24 ¹ / ₄ x 26 ³ / ₁₆
EQSMLL0002	SML2	1800 x 1400 x 1350	70 ⁵ / ₁₆ x 55 ¹ / ₈ x 53 ⁵ / ₁₆	1000 x 1300	39 ³ / ₁₆ x 51 ³ / ₁₆

Heated Glass Vacuum Press

A highly efficient heating system with user-friendly digital display and controls that ensure even distribution of heat providing the best mounting, heat-sealing and canvas-bonding. The transparent top panel comprises two sheets of reinforced tempered glass and offers a high level of operator confidence as work can be viewed in situ and allows final adjustments before pressure is activated, assuring correct alignment of work. The glass is extremely smooth and scratch-resistant.

Can also be used as a cold press for wet tissue and paper repairs.



Features

- *Adjustable Temperature Control* – Indicates the actual glass temperature and maintains that temperature at your chosen pre-set level.
- *Timer Control* – Most useful when processing large work volumes, the programmable timer can be set to the minimum time required for each batch so increasing productivity.
- *Pressure Control* – Minimises even heavy creases and wrinkles while ensuring that delicate items such as foamboard and embossed prints are not crushed.
- *Dedicated Vacuum Pump* – Factory-matched vacuum pump so that pressure is never pulled too quickly or slowly.

Product code	Model	Working dimensions mm	Working dimensions inches	Time to vacuum (secs)	Time to temp (mins)
EQHGVPO260	HGP2537	890 x 1195	5 ³ / ₆₄ x 47 ³ / ₆₄	20	12
EQHGVPO360	HGP3547	1095 x 1705	43 ³ / ₆₄ x 67 ¹ / ₈	20	12
EQHGVPO560	HGP5098	1276 x 2496	50 ³ / ₆₄ x 98 ¹ / ₆₄	30	15

Exhibition and Display Mounter

Designed to be simple to operate, whilst producing exhibition and display work and graphic panels to the highest professional standards. Can handle all types of flat artwork from photographs and paper posters to delicate plastics and vinyl. Not for use with historical items.

These versatile laminators can handle materials up to 25mm thick, including card stock, foamboard, MDF or rigid PVC board. Both machines feature a variable-speed electric drive with forward and reverse actions. The high-quality rollers assure even pressure across the width of the machine, while the convenient foot control pedal leaves hands free to handle input materials.



EQEDDM6204

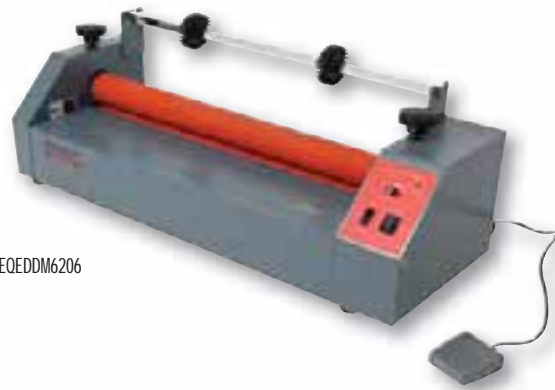

EQEDDM6206

Product code	External mm (and inches)	Maximum dimensions (L x W x H) mm (and inches)	Max opening laminating width mm (and inches)
EQEDDM6204	385 x 310 312.5 (15 ¹ / ₂ x 12 ³ / ₆₄)	667 (26.2)	19 (0.75)
EQHGVPO360	1540 x 480 x 480 (60 ⁷ / ₈ x 18 ³ / ₆₄ x 18 ³ / ₆₄)	1121 (44.12)	25 (1)
EQEDMS6218	Stand for EQEDDM6206		

Accessories and consumables

Double-sided mount film code	Dimensions mm	Dimensions inches
EODSMF3165	650 x 25M	25 ⁹ / ₃₂ x 82R ¹ / ₄
EODSMF3174	1040 x 25M	40 ¹ / ₁₆ x 82R ¹ / ₄
Foam-centred Board		
EQFCB05375	762 x 1016	30 x 40
EQFCB05380	1016 x 1524	40 x 60
White Display Board		
EQWDB05080	815 x 1120; 2000 micron	32 ¹ / ₂ x 44 ¹ / ₂
EQWDB05081	1040 x 1550; 2000 micron	40 ¹ / ₁₆ x 61 ¹ / ₂
Heat-seal Laminate		
SUHLMS1450	1300 x 25M	52 ² / ₆₄ x 82R ¹ / ₄
EODRYP6068	600 x 680	23 ³ / ₈ x 26 ⁹ / ₆₄

Paper Dryer

A complete system which is both practical and looks good, made up of drying racks and a wall support (optional). Drying racks are manufactured with a fibre-glass screen held in place by a PVC frame. Light and strong, they can be stacked in batches of 4 using the right clips and placed on a work surface, or they can be installed using the wall support (up to 10 frames).

The rigid PVC wall support includes side blocks into which the racks are fitted. After use, the racks can be lifted up again and wedged into a vertical position when they are not being used: a clever space-saving system.

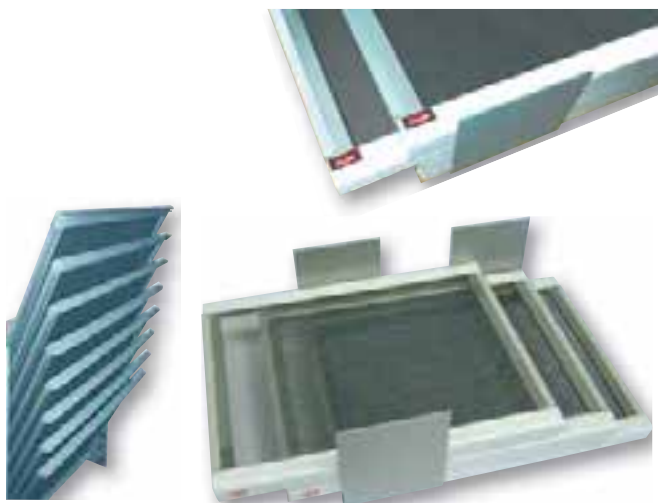

Product code	External mm
EODRYP6068	Working Area 600 x 680mm
EODRYC1514	Right Clips for use with Paper Dryers
EODRYCS7110	Wall Support to hold up to 10 Paper Dryers

Planorama® Drying Rack

Planorama® Drying Rack with either 10 or 20 x 10mm shelves, each with a mesh base. External dimensions of 1100 x 760 x 740mm or 1100 x 760 x 1350mm should allow the unit to fit through most doorways. The aluminium side panels are precision-punched, folded and then fitted with Planorama® gliding strips to form shelves that are smooth-opening and closing. The Saatifil™ polyester base has been used to remove any chance of leaving a pattern when drying maps, prints or drawings. After washing, a mesh with a more open weave can be supplied or the rack can be supplied with mixed shelves as requested.

Bespoke sizes and alternative fabrics available on request.



 *Linked Products: Planorama® Drawer System 233.*

Product code	No. of shelves	Working dimensions mm	Working dimensions inches	External dimensions mm	External dimensions inches
EOPLDR0001	20	935 x 639 x 10	36 ³ / ₁₆ x 25 ²⁵ / ₃₂ x 2 ⁵ / ₆₄	1100 x 760 x 1350	43 ⁵ / ₁₆ x 29 ⁵⁹ / ₆₄ x 53 ¹ / ₂
EOPLDR0002	10	935 x 639 x 10	36 ³ / ₁₆ x 25 ²⁵ / ₃₂ x 2 ⁵ / ₆₄	1100 x 760 x 740	43 ⁵ / ₁₆ x 29 ⁵⁹ / ₆₄ x 29 ¹ / ₆₄



Heat-Sealing and Welding Machines

Criss Cross Heat-Sealing Machines Table Top Sealer for Polyethylene or Polyester

This range of impulse sealers has either two heated 9.5mm wide x 610mm long welding jaws, suitable for laminated materials including Escal Neo™, foil bags and general polyethylene type products or two 1.5mm wide x 610mm long welding jaws suitable for standard polyester or CXD Crystal Polyester type 2. There are two settings on the machine for weld and cooling time meaning a consistent, high-quality seal can be reproduced. The machine also features a built-in compensation device to reduce the weld cycle if the machine is being cycled too quickly for more consistent welds. The foot-operated sealing jaws eliminates operator fatigue and speeds up production.

Accessories for the Criss Cross Table Top Sealer include a 254mm-deep tray attachment to increase the length of the tabletop welder in front of the welding jaws plus a manual cutter assembly which fits behind the welding jaws and has a safety knife attached to the top jaw. As soon as the weld starts, the knife may be depressed and drawn across the material roll.

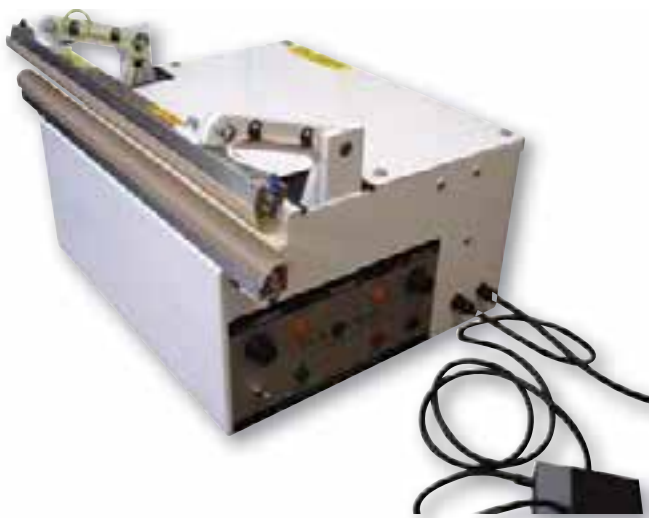

 *Linked Products: Polyester Rolls p77; Escal Neo™, Mitsubishi PTS and ArchiPress pouches p80; and CXD Crystal Type 2 p69.*

Product code	Description
EQIWTT0610	Table-top Sealer with 9.5mm Escal Neo™ Element
EQIWTT0611	Table-top Sealer with 1.5mm Polyester Element
EQIWCA0610	Manual Cutter Assembly For EQIWTT0610
EQIWFT0610	Support Tray For EQIWTT0610

Criss Cross Remote Sealer

Selected for their seal quality and versatility achieved by separating the power pack from the welding jaws, for customers requiring to change between Escal Neo™/Polyethylene-type sealing and Polyester welding.

Criss Cross Power Pack

To operate the jaws a power pack is required, the Standard Power Unit will power the Escal Neo™ jaws whilst the Universal Power Unit will power both types therefore representing the greatest value.



 *Linked Products: Polyester p67; Polyester Rolls p77; Mitsubishi PTS Pouches p80.*

Product code	Description	Size mm	Size inches
EQIWPU0001	Standard Power Unit	240	9 ⁵ / ₁₆
EQIWPU0002	Universal Power Unit	42	1 ⁷ / ₁₆

Criss Cross Remote Welding Jaws

There are two types of welding element; one for Standard and CXD Crystal type 2 Polyester with a 1.5mm wide weld and another with a 9.5mm wide weld for Escal Neo™, Polyethylene etc (CXD Crystal Polyester type 2 can also be welded at this width). Each element available in three lengths 150, 305 and 460mm.



The jaws are held together with a 'mole grip' type clamping system and a button on the jaws is used to activate the weld where necessary. Continuous welds can be made by sequentially joining welds together.



 *Linked Products: Polyester Rolls p77; Rotary Cutters p151. Escal Neo™ p182; Aluminium complex p81, Moistop, RIBS foil and Corrosion Intercept p106.*

Product code	Type	Length mm	Length inches
EQIWRJ0150	Escal Neo™	150	5 ⁹ / ₁₆
EQIWRJ0305	Escal Neo™	305	12 ¹ / ₁₆
EQIWRJ0460	Escal Neo™	460	18 ¹ / ₁₆
EQIWRJ7150	Polyester	150	5 ⁹ / ₁₆
EQIWRJ7305	Polyester	305	12 ¹ / ₁₆
EQIWRJ7460	Polyester	460	18 ¹ / ₁₆

Ultrasonic welding

Original Curateur™ Polyester Edge Welder

This product, exclusive to CXD, is an extremely robust machine (weighing approx 40kg) made with high-quality components and powder-coated finish.

The Curateur™ welder was the first desktop portable polyester welder and was introduced to the market in the late 1980s. This rugged machine soon found favour with conservators and others making polyester pockets; and, as far as we know, most of these original machines are still working.

The device has been developed to give greater flexibility and productivity by increasing the weld length to 800mm and making the tray detachable allowing easy storage and shipping. The alignment grid is unlike others, which are screen-printed direct to the tray where it is likely to wear or get scratched. The new Curateur™ Welder has the grid printed on a replaceable, self-adhesive thin sheet of polycarbonate.

The CXD Original Curateur™ comes complete with a spares kit, which includes a spare element and other consumable parts that may be needed.



 *Linked Products: Polyester Rolls p77; Rotary Cutters p151.*

Product code	Description	Size m	Size inches
EQPWOC800	800mm Weld Length UK Model		31½
EQPWOC1800	800mm Weld Length 110v Model		31½
EQPWR14049	Ribbon Element	1	39⅞
EQPWTG0800	Replacement Tray Grid		

Sonic Weld

Handheld, portable ultrasonic welding tool that is ergonomically designed to be lightweight and well-balanced allowing the operator to use the device like a pen. This allows bespoke, precise and permanent welds between layers of inert film such as polyester, ensuring the documents or objects are held in place without adhesives or physically touching the items. The system consists of a generator, lightweight RF cable and handgun with 1.5mm titanium-domed, spot-welding tool.

Accessories are available including easily interchangeable tools for precise cutting, shaping or trimming, spot-welding tools with different dimensions and a tripod for precision spot-welding. Please contact CXD for a full technical specification.



Specifications

- Frequency: 35kHz
- Power: 500 watts
- Mains Input: 240 volts 5 amp (single-phase)
- Generator: 320 x 340 x 180mm, weight 7.5kg
- Hand tool length: 240mm including standard spot-welding horn, weight 370gm
- Diameter: FNSA 42mm

Product code	Description	Size mm	Size inches
EQUWP9500	Deluxe Ultrasonic Welder	320 x 340 x 180	12 ⁵ / ₁₆ x 13 ⁵ / ₁₆ x 7 ¹ / ₂



Box-Measuring and Making

KASE MAKE CXD

In 1992 Conservation By Design produced the first bespoke Premier Duo™ Archival Solidcore boxes made on a Kasemake CXD computer-aided design and boxmaking machine. In 1996 CXD sold the first European system for in-house customer use to the National Library of Scotland.

Since that time the Kasemake CXD and Premier Duo™ Archival Boxboard range has established itself as the conservator's choice in libraries and archives worldwide and liberated their imaginations to create unique custom-made preservation solutions.

Kasemake CXD software is based upon the Windows operating system which makes a highly complex and powerful tool quick and easy to learn by new users.



The software contains an extensive library of designs conforming to the international standards for both solid board (ECMA) and corrugated board (FEFCO). Using the Kasemake CXD software, box designs from these libraries can be manipulated and sampled to create new designs as required. In addition, an extensive and ever-growing library of designs created specifically for the conservation of books and archive documents is included in the package. The Kasemake CXD Library and Archive user-group also share designs and knowledge of the system.

The creasing and cutting table comes in two models; 'The Library and Archive Mini Grand' and 'The Library and Archive Grand' which differ only in the working area; 1700 x 1300mm and 2500 x 1600mm, respectively. Both tables provide the same accurate cutting and unmatched creasing of CXD Premier Duo™ Solidcore and Corrugated boxboard. Kasemake CXD offers one tool carriage as standard which carries two cutting knives a creasing tool and a plotting pen.

There are two knives because the 'Tangential Drag Knife' is designed for use with solidcore board and the 'Electric Oscillating Knife' is for corrugated board and foam up to 15mm thick.

At the heart of the Kasemake CXD is the 'Tangential Creasing Tool' which is driven by powerful servo motors that ensure enough pressure is delivered to the creasing wheel.

This power is needed to ensure that Archival Solidcore board folds well with minimum cracking along the creases.

The plotting pen uses a bleed-proof and light-fast black ink.

Specifications

Maximum speed: 600mm/sec

Precision: ≤ 0.1mm

Dedicated PC required to be used as the machine controller, can be supplied on request.

Electrical Requirements

Machine: 1 x single-phase 220V 50Hz 1.5KW

Vacuum Fan: 1 x three-phase 380V 50Hz 5.5KW

Compressed Air Requirements

Pressure: 7-8 Bar, (100-120PSI,)

Flow: 3.5cfm (170 litres/min)

Optional Compressor

Compressed air supply required for the sample tables which can be supplied by CXD as required

- 1 x Electric Oscillating Knife (capable of cutting up to 15mm corrugated)
- 1 x Tangential Creasing Tool
- 1 x Tangential Drag Knife
- Manual depth adjustment for cutting/creasing
- Differential creasing pressure (cross-flute and along-flute)
- 3 x Creasing tools suitable for corrugated board
- 2 x Creasing tools suitable for carton board
- 1 x Pen Tool, allows plotting onto die-board, film, etc
- Laser-pointer to help register jobs
- Vacuum-hold to secure sheet while cutting (3 zones)
- Servo motors on X,Y and C axes

24-month parts Warranty.

Please contact our sales department for a quotation

Accessories

Product code	Description	Dimension mm	Dimension inches
EOKASE0500	Kasemake Carbide Blade		
EOKASE1045	Kasemake Disposable Head Blade		
EOKASE2237	Kasemake Refill Pens Black		
EOKASE4110	Kasemake Cutting Mat	1960 x 2625	77 ¹¹ / ₁₆ x 8ft 7 ¹ / ₂

The Kasemake CXD Library and Archive - Boxmaking System

Model: Mini-Grand, working area: 1700 x 1300mm

Model: Grand, working area: 2500 x 1600mm



Kasemake CXD Digital Book Measure

In 2006 the Kasemake CXD Digital Book Measure was introduced. This is used in conjunction with the Kasemake CXD boxmaker. It is a tablet-based measuring device combined with easy-to-use capture software that permits error-free measurements of a book or archive object.

This clever device has its own software and can work independently of the main Kasemake CXD system, allowing it to be used in remote repositories to capture dimensions, title, author, archive or shelf reference number and other customised information as required. In addition to this cataloguing data, details on the required boxboard, box style and job priority can be specified. This information can be sent in batches via a network connection, email or USB memory stick to a Kasemake CXD boxmaking machine. Logged information can be written on the box using the machine's plotting pen to ensure that boxes can be matched to the correct object. Available in 3 popular sizes that will suit most Library and Archive needs – A0, A1 and A2.

Because it has stand-alone software it can be bought by a small institution which might not have the space or budget for a Kasemake CXD boxmaker but have a large requirement for custom-made boxes and folders. Measurements and data can be sent to Conservation By Design's 'Smart Box™' service or any other Kasemake CXD boxmaker offering a similar service.

Product code	Size guide
EQKDBM0000	A0
EQKDBM0001	A1
EQKDBM0002	A2



CXD Manual Book Measure

This solidly built, hand-crafted unit provides a quick and accurate way of determining the dimensions of books for archival boxmaking where budgets or volume of work do not warrant the Kasemake CXD Digital Book Measure to be used. Features a smooth-sliding mechanism and simple construction. Suitable for taking measurements up to 600mm graduated in 1mm increments. Can be supplied with Imperial (inch) measure on request.

Product code	Description	Size mm	Size inches	Dimensions (L x D x H) mm	Dimensions (L x D x H) inches	Weight kg
EQKMBM0600	Book Measure	Up to 600mm	Up to 23 ³ / ₄	725 x 400 x 170	28 ³ / ₄ x 15 ³ / ₄ x 6 ¹ / ₁₆	10



Riveting Presses

Hand-operated, benchtop machine for attaching rivets and eyelets.



 *Linked Products: Rivets p124.*

Product code	Description	External dimensions mm (H x W x D)	External dimensions inches (H x W x D)	Throat mm	Throat inches	Weight kg
EQHRWP0100	Riveter Pro	360 x 100 x 240	14 ¹ / ₄ x 3 ³ / ₈ x 9 ³ / ₄	105	4 ¹ / ₄	3.8kg
EQHRJR1000	Rivet Junior	information on request				

Portable Rolling Creaser

Developed by Dr. Nicholas Pickwood, book conservation consultant to the National Trust, and manufactured by CXD, this is a tabletop and portable machine. The Rolling Creaser deploys a brass-creasing wheel mounted in a carriage; two precision-ground tracks run over a groove formed by adjustable stainless steel bedplates. Creases can be formed at right angles to the edge. The unit is designed to crease 1300-micron Conservation By Design Premier Duo™ Archival Folding Boxboard, but an optional smaller creasing wheel accommodates thinner boards. Working lengths of 27" and 41" are available from stock, with special sizes available up to 65".



 *Linked Products: Premier™ Archival Folding Boxboard p110; Heritage Library Tying Tape p135.*

Product code	Description	Dimension
EQPRCR1041	CXD Pickwood Board Creaser	1041mm (41")
EQPRCW1000	CXD Pickwood Board Creaser Wheel	To Crease 1000 micron board

Pest Management

Cockroach, Silverfish and Crawling Insect Traps

The Detector trap is used for cockroaches, silverfish and other crawling insects. Features a cardboard panel covered with adhesive. An attraction disk with pheromones and food bait is placed in its centre to attract the cockroaches and trap them therein. Size 195 x 10mm. Can be divided to 3 small traps. 10m² is ideal for 2 traps and 4 or 6 weeks.

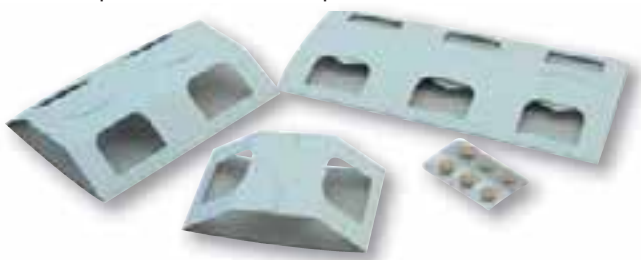

Product code	Description	Pack qty
EQINSE001	Cockroach and Silverfish Trap	3

Wool Moth Traps

The moth traps should be placed in storage areas or close to at-risk items all the year round. Risk of attack varies with climatic conditions and other factors such as central heating, etc.



Positioning of the traps and quantities for good control: this insect is not very good at flying and never ventures far from the source of infestation; the traps should be placed on shelves or on the floor, close to the materials needing protection.

Avoid hanging the traps. If, for practical reasons, the traps need to be hung, they should be placed as low as possible over the articles to be protected. One trap is enough to protect a particular volume, such as a wardrobe. With larger areas use one trap for every 70m³.

Trap life is approximately 10 to 12 weeks. Size: 195 x 10mm.

Product code	Description	Size mm	Size inches	Pack qty
EQIWSE002	Wool Moth Trap	195 x 10	7 ³ / ₄ x 0 ² / ₄	1

Textile Mothproof Spray

The Mothproof Spray contains azadirachtin, an extract from neem seed (the neem tree is native to India). The repellent insecticide properties of the neem tree are widely recognised. This substance effectively protects textiles against moths or textile bugs. The addition of essential oils gives it a pleasant, discreet fragrance. The effects last about 6 months for stored textiles.

Composition: Plant alcohol, neem extract, combination of essential oils (lavandin, Mexican juniper and Java citronella).



Product code	Capacity ml
EQTEXT0050	50
EQTEXT0200	200

Insect and Pest Traps

Triangular-shaped, these blunder traps are commonly used by conservators and others to monitor insects in buildings. Inert, non-toxic, disposable sticky trap.



Product code	Description	Pack qty
SUMUTR001	Museum Trap Standard	1

Textile Moth-Repellent Vaporising Card

Long-lasting, 100% natural protection for textiles. The vaporising cards contain 100% natural moth-repulsive scents, featuring no synthetic substances. The essential oils are released consistently and are effective for up to 3 months.



The protective effect of this product has been established in test laboratories. The vaporiser is activated as soon as the protective film is removed.

- Installation: Vaporisers can be hung from the closet rod or placed in shelves or drawers. It is recommended to note down the date on which they are placed on the integral label.
- Lifespan: 3 months, to be replaced as soon as this timescale elapses even if you still see some liquid in the vaporiser (soya oil, a support to the active substance, does not evaporate).

Product code	Description	Pack qty
EOTEXT002	Moth Repellent	2

Pistol™ Anti Wood-Pest Spray

The action of the spray is based on the natural insecticidal properties of the extract pyrethrum (species of chrysanthemum). Pyrethrum has an immediate, devastating impact on pests (paralysis and destruction). Unlike a lot of products available on the market, it does not contain any synthetic additive (PBO). This means that it degrades more quickly (caused by ultraviolet rays), making it harmless to humans and hot-blooded animals. The spray can also be used on a preventive basis, since pests tend to avoid objects treated with pyrethrum. The presence of pests in wood can often be observed after a complete generation has been developed. The holes that become visible are made by adult insects who come out in search of mates. By this stage the larvae, which cause the damage, have already dug tunnels. Pistol™ is a contact-based insecticide. Depending on the degree of infestation it may be necessary to lightly punch the surface to enable the product to penetrate.



It may also be applied with a brush or through injection. Pistol™ has been popular for some time with object conservators in Germany but is less well-known in other markets.

Product code	Capacity ml
EQIWSE0010	200

Bambule® Anti-Insect Spray

Bambule® Anti-Insect Spray effectively combats all flying or crawling insects and their eggs and larvae, both inside and outside. Harmless to humans and pets, it impedes the vital functions of insects (preventing feedings, growth and reproduction).

Composition: Demineralised water, food emulsifier, neem extract, synergy of essential oils (lavandin, clove tree and Java citronella).



Product code	Capacity ml
EQIWSE0050	50
EQIWSE0200	200

Bozone Gels

Highly efficient anti-bacteria and insect repellent agent (Patent No. 0421538)

Bozone was developed with The Korean National Research Institute of Cultural Heritage and patented by the Korean Government to meet the demands of their deteriorating collections due to insects and micro-organisms.

Manufactured from natural medicinal herbs, this environmentally friendly and harmless product disperses a gas to reduce the growth of bacteria and mould and repel insects.

Bozone is available in a variety of sizes and forms to suit most applications. For larger applications the 70ml Bozone Gel with integral diffuser is ideal for areas up to 6.6m² unaided, or between 10 – 15m² when aided with by the aroma fan.

For drawers or small display cases a smaller 35ml version is available suitable for areas up to 2.5m² with integral diffuser. For very small spaces, less than 0.1m², Bozone is available in a non-woven box.

Applications

- Display cases
- Storage areas

Image	Product code	Description	Pack qty
A	EQBCGE0070	Bozone Gel 70ml	1
B	EQBCGE0035	Bozone Gel 35ml	1
C	EQBCNW0001	Bozone Non-woven	1 Pair



Oxygen-Free Storage and Treatments

The development of oxygen-free storage products.

Since the company was founded in 1992, Conservation By Design has been involved in the development of oxygen-free storage and display products for use within the conservation and preservation profession. The elimination of oxygen is the way forward for many difficult preservation problems whether it be the eradication of pests, preservation and drying of flood-damaged material, document storage or the storage and display of plastics, rubber and geological specimens that are particularly sensitive to oxidation and damage from UV.

We supply vacuum-packing machines, transparent barrier pouches, barrier films on rolls, Ageless® and RP System™ oxygen-scavengers, Ageless® Eye oxygen-indicating tablets, and the CXD KnoOx™ oxygen-monitoring sensors and equipment.

Special oxygen-free enclosures and showcases are also available.



Oxygen absorber packets have been used extensively within the food and electrical packaging industry and more recently for the conservation and preservation of a wide variety of cultural objects. They are used inside high-oxygen barrier film packets sealed with or without a vacuum. The sachets are capable of reducing the oxygen in an airtight container to less than 0.01% (100ppm) and can maintain this level indefinitely depending on the oxygen permeability of the packaging material. Long-term packaging of museum objects requires a packaging material that is virtually impermeable to oxygen and moisture. Recent research work carried out within museums has found oxygen-free storage to have many benefits for the storage of historical objects and natural history collections. Many of these objects contain modern or synthetic substances that can deteriorate even in the best conventional archival storage materials available. This is because, although they are pure and non-reactive, they do not tackle the problem of excluding the main cause of deterioration — oxygen. Oxygen-scavengers are also used in conjunction with barrier film for the eradication of insects and pests.

Various types of oxygen-scavenger can be supplied for museum storage and pest eradication. Before the introduction of the Mitsubishi RP System™ (Revolutionary Preservation) which has been developed specifically for museum preservation, Mitsubishi Ageless® Z was the most commonly used type.

As a general rule it is better to use too much scavenger material than too little. Results can be checked using Ageless® Eye oxygen-indicator tablets. We also recommend the insertion of Humidity Indicator Strips within Escal Neo™ or PTS Bags because the Ageless® Eye itself has a limited life as a monitor. A new generation of oxygen-monitoring equipment is now available but at a price that is only likely to be within the reach of the larger user.

Conservation By Design are proud to have been appointed as agents for the conservation market of **Mitsubishi Gas Chemical RP Oxygen Scavengers**. We offer the following types of film and bags:

- Escal Neo™ film
- PTS bags
- Aluminium Foil Bags

Information on how to calculate the amount of RP scavenger agent pouches required are shown on page 181.



RP Oxygen-Absorbing Scavengers

The RP System™ is a handy packaging system that protects artefacts from degradation, creating an atmosphere without oxygen, moisture or corrosive gases, which are the main causes of metal oxidation.



RP System™ Type A

Removes: Oxygen, moisture and corrosive gases

Mitsubishi RP-A 'stops the clock' on the sources of corrosion and oxidation of metals through a chemical reaction that removes oxygen, moisture and corrosive gases from sealed containers.

It is used in metal conservation and other applications where a low RH is required i.e. geological specimens. It may also have applications for the storage of audio tapes where oxygen and moisture are primary sources of deterioration.

Research is underway to determine the range of uses.

Application Examples

- Archaeological metals
- Coins
- Cutlery
- Jewellery
- Arms

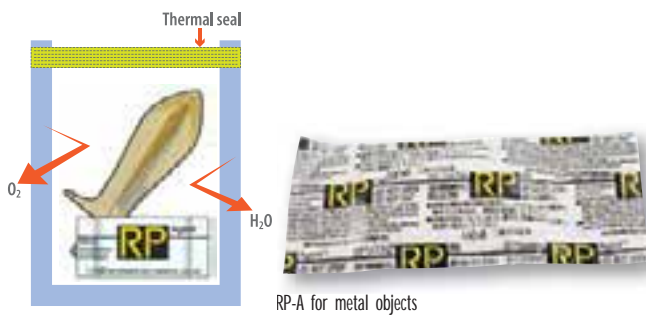

Product code	Description	Size mm	Size inches	Pack qty
SURPSA0001	Sachet 100ml	28 x 55	1 ¹ / ₆₄ x 2 ¹ / ₆₄	25
SURPSA0003	Sachet 300ml	35 x 120	1 ³ / ₈ x 4 ²³ / ₃₂	25
SURPSA0005	Sachet 500ml	51 x 120	2 ¹ / ₆₄ x 4 ²⁵ / ₃₂	25
SURPSA0020	Sachet 2000ml	95 x 100	3 ⁴¹ / ₆₄ x 3 ¹⁵ / ₁₆	10

Archaeological finds



Ageless® Type ZPT

Removes: Oxygen

Ageless® Z scavengers are used in conjunction with moisture-permeable, transparent, laminate, oxygen-barrier bags – similar to our ArchiPress™

Pouches – and are recommended as an insecticide of non-metal artefacts for short periods of around one month. Escal Neo™ or Aluminium Foil should not be used because they will retain the moisture given off during the active period of the Ageless® Z.

However, if the high humidity adversely affects the artefacts, even if it is for a short time, add some silica gel or use RP-K.

NB: Supplied vacuum-packed. Do not open until required for use.

Product code	Description	Pack qty
SUAGEL0200	Sachet 200ml Ageless® ZPT	100
SUAGEL1000	Sachet 1000ml	50



RP System™ Type K

Removes: Oxygen and corrosive gases

This type of scavenger should, for example, be used for organic objects or for metals that are combined with organic material such as wood or bone. RP-K can also be used for leather, paper and textiles etc. It does not affect the moisture in a container to protect photographs, films, dyed products from discolouring and fading. (UV light damage is stopped with the absence of oxygen). RP-K also prevents mildew and insect damage to paper, textiles and wooden artefacts.

Application Examples

- Historical objects
- Pictures
- Books
- Graphic works
- Textiles

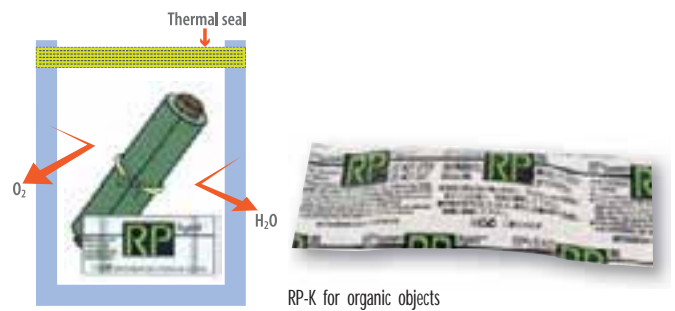

Product code	Description	Size mm	Size inches	Pack qty
SURPSK0003	Sachet 300ml	35 x 120	1 ³ / ₈ x 4 ²³ / ₃₂	25
SURPSK0020	Sachet 2000ml	100 x 130	3 ¹⁵ / ₁₆ x 5 ¹ / ₈	25

Textiles



Packaging



Functions of RP Oxygen-Absorbing Scavenger Agent

When a specified amount of RP Agent (A or K) is sealed up in an appropriate barrier bag, the graphs show the following:

- 1 The oxygen concentration falls below 0.1%
- 2 With the A type, the relative humidity falls below 10%; with the K type, the initial humidity is maintained
- 3 The concentration of each kind of corrosive gas falls below 1ppm

Disposal of RP Agent

RP Agent may be deposited in landfill or incinerator in accordance with National and Local regulations. RP Agent is not considered a hazardous waste under current RCRA regulations.



Ageless® Eye Oxygen-Indicating Tablets

Ageless® Eye Oxygen-indicating tablets verify that all the oxygen has been absorbed from your package. They start off pink in colour but, when opened and inserted into the package, they will turn blue. Once the package has been sealed, and providing that there are sufficient oxygen absorbing sachets for the volume of air, the tablet will turn back to pink when oxygen concentration is below 1%. This will not happen instantly and may take some days. Flushing with nitrogen gas will speed up the process, but in normal use squeezing out excess air before sealing will help.

The shelf life is limited and life within the package may not exceed six months. This unfortunately means you cannot rely on it as a monitor for oxygen within the package on a long-term basis and it should only be seen as an indication that the Ageless® or RP Agent has worked at the time of initial packaging.

A new generation of oxygen-monitoring equipment is now available for the larger user. It is important to handle the sealed packages carefully as bad or careless handling can lead to the bag being punctured and oxygen leaking into the package. This is less of a problem with vacuum-packed oxygen scavengers because it is immediately obvious when a vacuum pouch has punctured as it inflates and loses the rigidity created by the process of vacuum-packing. Air contains 21% of oxygen and when this is removed by the scavenger a slight vacuum is created. This vacuum is another indicator that oxygen has been removed.

How to select the correct RP Agent and pouches

Choose the size and number of RP Agent pouches to be used based on your estimate of the air content of the container.

Sample calculation Total weight: 1200g Specific gravity: 4
 $W \times L \times H = 20 \times 30 \times 3 = \frac{1200}{4} = 1500 \text{ ml} = 3 \text{ pouches of RP-5}$

Calculation methods also apply to Ageless® Z PT and other types of sachet.

How to calculate air content

$$\text{Air content (ml)} = \text{Total volume of bag (ml)} = \frac{\text{Weight of product (g)}}{\text{Specific gravity of contents}}$$

For square containers, measure the dimensions to calculate the total volume. Include trays, cushions and other such materials in calculating average specific gravity of contents.

$$\text{Total Volume (ml)} = W(\text{cm}) \times L(\text{cm}) \times H(\text{cm}) = 20 \text{ cm} \times 30 \text{ cm} \times 3 \text{ cm} = 1800 \text{ ml}$$

Guidelines for the amount of RP Agent to be used

Bag size mm	180 x 250	220 x 300
RP Agent size	RP-3 or RP-5	1
Number of pouches	RP-5	1 - 2

For more detail on graphs view at www.cxdltd.co.uk

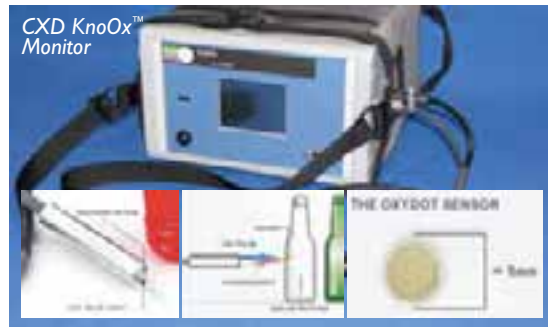
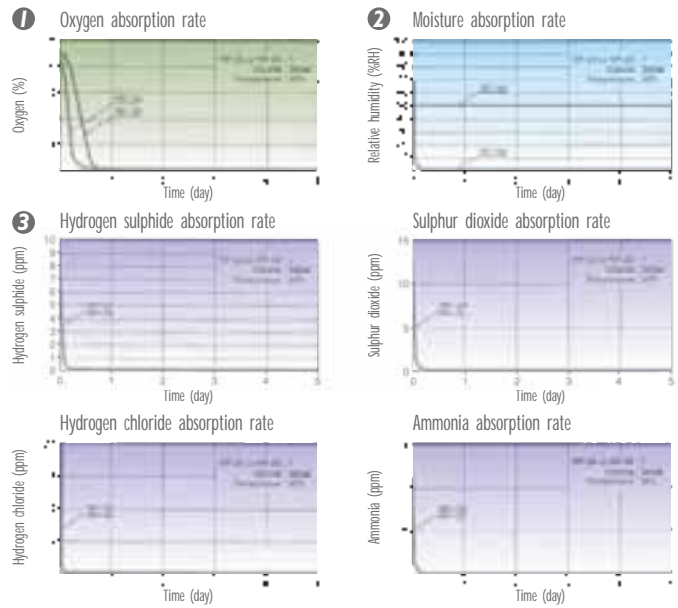

An oxygen-indicating tablet will be blue in normal atmosphere and pink when concentrations of oxygen are below 1%. This colour change is reversible, so that a single oxygen-indicating tablet can be reused many times.

For longer term accurate measurement and monitoring we are now able to offer the CXD KnoOx™ oxygen sensor and indicator eyes. These can be sealed inside the package and read with the KnoOx™ pen. Data is visible on the screen and can be downloaded direct into the software.

For more details see page 184.

Product code	Description	Pack qty
SURPEY0000	Oxygen-indicating Tablet	25

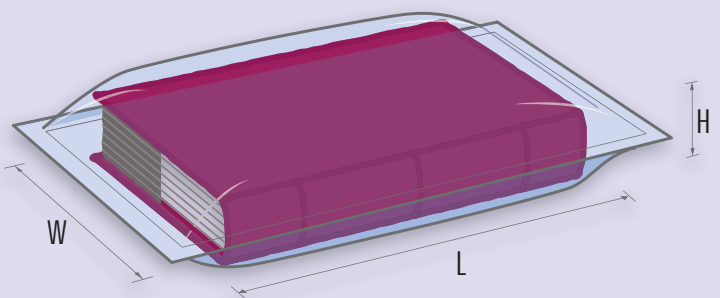

- To measure the total volume of a film bag, suppose that the bag containing an object is in the form of a square or rectangular box. Take an approximate measurement of its length, width and height, using a rule
- Measure the weight of the object that is in the bag
- For the specific gravity, use your judgement, based on the following: the specific gravity of iron is 7.9; copper is 8.9
- If the object is crusted with rust, its specific gravity is less than a pure metal
- Ignore the volume of the object contained in the bag if its calculation is troublesome
- 1 package of RP-5 is required if the resultant air capacity is less than 500ml
- 2 packages of RP-5 for an air capacity of 1 litre/1000ml
- Enclose an increased quantity of RP Agent when the earth adhering to the artefact is still wet immediately after excavation and temporary preservation is necessary
- One package of RP-5 can absorb moisture equal to about 1ml
- Remember it is better to use too much than too little RP Agent as any excess will act as a buffer against long-term leakage of oxygen and extend the life of the package.

Escal Neo™ System, Ceramic Deposited Gas Barrier Film

A 'transparent', high moisture and oxygen barrier film for use with RP sachets.

Escal Neo™ System for the protection of cultural properties supplied in single sheet rolls or double sheet tube rolls. The material is a ceramic deposited super-barrier film developed especially for use with the Mitsubishi RP System™ (p180). The user can unroll and cut the Escal Neo™ System film to a desired length and seal with a heat sealer. Each Escal Neo™ System film roll includes a continuous data entry space with a white writable background.

Escal Neo™ System has an outstanding ability to keep out moist air. It is therefore very useful not only for the preservation of damp, wooden artefacts, but also for all other conservation or storage purposes. On the other hand, the RP Type A agent works to keep the inside atmosphere of a container very dry, therefore it is not appropriate for conservation or storage of small quantities of paper/textile materials or wooden artefacts, which require a more normal RH.

Mitsubishi have developed another type called RP-K which does not affect the moisture in a container and which therefore can be used for non-metallic artefacts. This product is mainly used to protect photographs, films and dyed products from discolouring and fading. It also prevents mildew and insect-damage to paper, textile materials and wooden artefacts.

Product code	Size mm	Pack qty
SUESNE7754	W160 external (140 internal)	Per metre length
SUESNE7755	W240 external (220 internal)	Per metre length
SUESCA0480	W480 external (460 internal)	Per metre length
SUESNE7756	W1000	Per metre length

Using Escal Neo™ and the RP System™

Metal artefacts and many museum objects can be perfectly protected from retrogradation by removing oxygen and moisture content with **RP Type A** oxygen and moisture scavengers.

RP Type K is moisture-neutral and will not remove moisture from the enclosure. However the moisture barrier created by the **Escal Neo™** or **PTS** enclosure ensures a stable microclimate for the enclosed object.

This means that the period during which the quality of these artefacts can be preserved depends on the correlation between the barrier performance (oxygen permeability and moisture permeability) of the film and the enclosed amount of RP Agent.

The barrier film should have a particularly good gas-barrier performance in both oxygen and moisture permeabilities.

 *Linked Products: Ageless and RP System™ p180; Vacuum Packing Machines p168.*



Coins

Comparison of film performance characteristics

- ✓✓ Escal Neo™, a continuous roll, gas-barrier film conserves metal artefacts for much longer
 - ✓ PTS Bags may work well enough for the conservation of metal artefacts for about one year or less
 - ✗ Films generally used for oxygen-free wrapping of food such as EVOH and PVDC films, are not applicable to this system because they are high in moisture permeability
 - ✗ Vinyl, nylon and polyethylene films cannot be used because they have insufficient barrier performance for this system
 - ✓ Aluminium foil is effective for semi-permanent conservation of metal artefacts. However, it is not transparent and does not allow the contents to be observed. For this reason, aluminium foil is not preferred in the field of cultural properties conservation
 - ▲ Deposited aluminium film has a better moisture barrier than most films but is not really recommended for use with the RP sachets except for temporary use
- Q. Can the RP Agent be used in combination with a commercial barrier film available on the market?
- A. Theoretically, commercial plastic films generally available on the market render a shorter moisture-free period, normally less than a month. Therefore, an effect identical to the proper film designated for RP System™ cannot be expected from these films
- RP System™ works as a long-term conservation method for cultural properties when applied together with the gas-barrier performance of Escal Neo™

Film performance characteristics (reference values measured at 25°C)

Suitability	Film	Oxygen Permeability (cc/M2.day.atm)	Water Vapour Permeability (g/m2.day)	Remarks
✓✓	Escal Neo™	0.05	0.01	A ceramic deposited film
✓	PTS	0.5	0.08	Same as above
✓	Aluminium (in foil)	< 0.01	< 0.01	Per metre length
▲	Aluminium (deposited)	0.2 – 6	0.5 – 6	Per metre length
✗	EVOH films	0.3 – 7	4 – 7 EVAL®, OV®, etc	Polyvinylidene Chloride coated films (KOP®, K Nylon, etc)
✗	PDVC films	5 – 15	4 – 7	
✗	Nylon films	30 – 120	5 – 15	
✗	Polyethylene	2000 –	5 – 15	



Q: Is it possible to preserve using only a rigid container with RP Agent enclosed?

A: No, it is not practical under present circumstances. If you use a rigid plastic container alone such as Tupperware® the pressure inside the container is reduced due to the oxygen-absorption by the RP Agent. This deforms the container and consequently some air can get into the container. If you want to use a rigid container, cover it with a sealed gas-barrier bag.



Q: How should we preserve an object with projections?

A: The RP System™ requires a completely sealed environment, which means you cannot obtain the desired preserving effect if a projection has made a pinhole in the gas-barrier film. To protect such projections, wrap up the object by cushioning materials such as a tray and bubble wrap sheet prior to RP packaging. Do not use a paper cushion using the RP-A Agent (which is the moisture-absorption type) because the RP-A Agent also absorbs moisture from the inside of the paper cushion. So the moisture-absorbing ability of the RP-A Agent may be wasted and also the paper cushion itself may deteriorate due to excessive desiccation.



Q: Is it possible to use in combination with a wooden case or box?

A: Yes, it is if you use the RP-K Agent which we call the moisture-neutral type. If using a wooden case, put a suitable amount of RP-K Agents inside and outside the case respectively, and then put the case in a bag. Finally, seal up the package. If you want to use an archival box, pack the box with the RP-K Agent placed between the box and the gas-barrier bag. Do not use the RP-A moisture-absorption-type agent.



Q: Is it possible to use for two or more objects each packed in a polyethylene bag for classification?

A: Yes, it is. If you pack two or more objects together — each packed in a polyethylene bag — an oxygen-free condition will be created in each polyethylene bag in a few days, since a polyethylene bag itself has a high permeability.



Q: Is it necessary to vacuum-pack the package with an RP Agent enclosed?

A: No, it is not necessary. If you try to vacuum-pack the package with an RP Agent enclosed, the package will be decompressed further due to oxygen-absorption, which causes the object to contact the inner surface of the gas-barrier bag too closely. When sealing the package, you must avoid this situation. Otherwise the object may be damaged or a pinhole may be formed on the inner surface of film due to excessive pressure from outside.



Q: Is it possible to reuse the RP Agent like a silica gel?

A: No it isn't. The RP Agent cannot regenerate its preserving ability. The silica gel physically retains moisture and emits it by drying. In contrast, the RP Agent absorbs oxygen, corrosive gas and moisture by irreversible chemical reactions. (The RP-K Agent does not absorb moisture.)

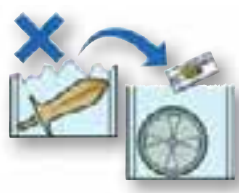

Q: Is it possible to reuse the Escal Neo™ or the PTS bag?

A: Yes it is possible if there is no flaw, fold, pinhole, etc. in the film. However, the RP System™ requires a completely sealed environment, which means the desired preserving effect cannot be obtained if there is a scar or hole in the surface of the gas-barrier film.



Q: Is any harmful substance used in the RP Agent?

A: No, both the RP Agent and the oxygen-indicators are made from non-poisonous ingredients; don't eat them or tear RP Agent pouches intentionally.



Q: How should we dispose of the RP Agent?

A: If you dispose of small amounts of RP Agent, it can go with general plastic wastes. If you dispose of a large amount of RP Agents, separate the RP Agent pouches from other disposal items by placing them in an airtight plastic bag (for example, a polyethylene bag), tie the mouth of the bag with as little air left inside as possible and keep it away from other materials until incinerating it at the earliest opportunity. A large amount of RP Agent will generate heat as a reaction of oxidation when they are accumulated together.



Q: How long can unused RP Agents remain effective?

A: No functional deterioration takes place as long as air is not let in. Accordingly, exert careful attention not to make any tear or hole in the external film. If you do not use the entire RP Agent at one time but use part of them in several instalments, some air must get in each time the aluminium bag is unsealed. Therefore, the RP Agent's preserving ability will deteriorate bit by bit, though at a low level. Whenever you take some Agents out, seal up the remaining Agents after expelling as much of the air from the aluminium bag as possible.



RP Agents are supplied vacuum-packed. Do not open until required for use.

SURPSA/SURPSK
Vacuum-packed in silver packaging

KnoOx™ 1000 Optical Oxygen Analyser System

OxySense® is the first non-invasive oxygen measurement system for sealed enclosures such as ArchiPress™, Escal Neo™ or other barrier bags. It is an optical system that can non-invasively measure oxygen concentration within packages that are transparent, semi-transparent, and translucent; and as long as the packaging material can transmit blue and red light (at approximately 470nm and 610nm respectively), a measurement can be made.



This system allows the production of bar codes, which can be scanned by the portable KnoOx™ 1000 to uniquely identify the object and record the oxygen level with minimum disturbance to the items being stored.

The technology relies on The Oxy2Dot®, which is a non-invasive, light-sensitive, oxygen sensor that is placed into the barrier bag prior to putting documents or objects in. Measurements are achieved simply with a fibre-optic reader pen from outside the package. All software required is included and is easily exported to Microsoft® Excel® for further analysis.

Specifications

- Gas O₂ operating range 0-30%
- Temperature range 0-60°C
- Lower detection limits 0.03% (300ppm)
- Accuracy 5% of the reading

Features

- Rechargeable long-life battery
- Real-time measurement and control
- User-friendly operation
- Easy-user calibration
- Barcode sample tracker
- Software
- Automatic data-logging

Advantages

- Verify and monitor low O₂ environments
- Ideal for specimen conservation
- Ideal for monitoring case and frame O₂ environments
- Measure, monitor and log thousands of specimens and cases with a single instrument
- Take the instrument to the work
- Minimal operating cost

 *Linked Products: Oxygen-free Storage p179; Vacuum Packers p185; RP Agent p181; Scavengers p180.*

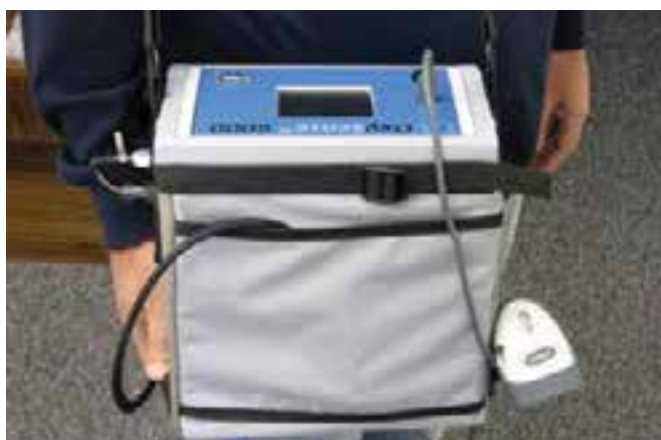

Mitsubishi Aluminium Foil Pouches

The pouches are a complex of plastic and aluminium foil. The inner layer being a heat-sealable polyethylene. The aluminium foil offers the best form of oxygen and moisture-barrier but, being opaque, the contents cannot be observed.



 *Linked Products: Oxygen-free bags and films p79.*

Product code	Size mm	Size inches
SUMALU2029	285 x 200	11¼ x 7¾
SUMALU3349	330 x 490	13 x 19¾
SUMALU3861	380 x 610	141¾ x 24

CXD Time Capsule

“Let future generations know tomorrow what you did today.” Store and record your memories of the 21st century in a time capsule made to last hundreds of years. Constructed in 4mm stainless steel, marine-grade (316 specification). Closed lid sealed via 18 x 10mm stainless steel bolts with gaskets to ensure a good seal.



The outside of the capsule has a bright colour powder-coated finish to assist in identification when being unearthed. Time capsules are manufactured in four sizes.

The RP System™ takes oxygen levels lower than simply flushing the capsule with nitrogen or argon gas and it continues to work scavenging oxygen from within the object. Pollution-scavengers within the RP System™ will clean the atmosphere of harmful degradation by-products given off by the objects being stored for future generations to enjoy.

To further protect and conserve objects from harmful gases within the capsule, we offer a number of other highly effective products for air-purification. For corrosion-protection use Charcoal Cloth®, CXD Purification Paint™, plus the unique copper-based Intercept Technology®.

 *Linked Products: RP System™ Pollution Scavengers p180; Charcoal Cloth® p107; Intercept Technology® p19.*

Product code	Size mm	Size inches	Weight kg
EQMTCO2001	300	11¾	12
EQMTCO3001	460	18¼	16
EQMTCO4001	610	24¼	22
EQMTCO5001	915	36½	34

Time Capsule For Britain's Oldest Dance Company



Images courtesy of Rambert Dance Company.

Nadia Stern, CEO of Rambert Dance Company, said: “Our Archive Team researched all the options and chose the CXD time capsule because we believed it to be the best quality, and we regularly source other preservation material from the company. With it, hopefully future generations of dance fans will have something very special that will remind them of our rich and varied history.”

The Rambert capsule will be registered with the International Time Capsule Society, with a request that it is not opened for at least 50 years.

CXD Vacuum-Sealing Machines

Operator Safety - CXD Vacuum-Sealing Machines remove the air from a bag, sometimes replacing it with inert nitrogen, then hermetically seal the package to give long-term, oxygen-free protection for the contents. Two types of machine are offered, Chamber and Vacuum Impulse. For operator safety CXD offer an exhaust which allows a hose to be attached to extract dangerous mould spores that can be present when used for Squelch Drying water-damaged documents.

Protection - High-oxygen barrier enclosures like ArchiPress™ pouches give the conservator a new weapon in the struggle to resist the persistent decay caused by time, pests and disasters. The strong air and watertight pouches give additional protection against acidity, atmospheric pollution, floods, fire extinguishers, damp, mould, mildew, insects, vermin, careless handling and damage in transit. Anoxic enclosures are used for pest eradication, disaster recovery and Squelch Drying and to slow down oxidation and damage from UV light.

Space-saving - Compared to conventional envelope storage, vacuum storage has the advantage of saving up to 40 to 50% of shelf space for the same volume of documents and could effectively double the capacity of an archive's shelving without the addition of a single extra shelf.

Security - The special vacuum-sealed pouches protect their contents against unauthorised access to security documents. The opening of pouches cannot go unnoticed and requires the use of a CXD Vacuum Machine to re-seal them. The pouches can also be printed with corporate logos and security or data-retrieval information. In addition, coded seals can be supplied that fit in to the machines effectively branding information into the weld that cannot be easily forged.

Institute of Egypt - Library Fire, Cairo, December 2011

<http://www.theguardian.com/world/2011/dec/19/cairo-institute-burned-during-clashes>



Fire and water-damaged books



Books being vacuum-packed with CXD Vacuum Impulse Sealer

CXD Vacuum Chamber Machines

A vacuum chamber removes the air out of a bag by use of a vacuum pump. On completion the bag is then sealed. Equipped with a clearly laid out and easy-to-programme digital control panel, each machine features a 10-programme memory. Additional filler plates are supplied in order that the working height inside the chamber can be adjusted for a variety of sizes of bag.

Product code	Type 160 EQSVMS0163	Type 300 EQSVVM0303
Machine size (L x W x H)	490 x 610 x 445mm 19 ³ / ₄ x 24 ¹ / ₄ x 17 ³ / ₄	900 x 820 x 1070mm 35 ¹ / ₂ x 32 ¹ / ₂ x 42 ¹ / ₂
Absolute chamber size (L x W x H)	420 x 500 x 180mm 16 ¹ / ₂ x 19 ¹ / ₂ x 7 ¹ / ₂	820 x 560 x 235mm 32 ¹ / ₂ x 22 ¹ / ₂ x 9 ¹ / ₄
Effective chamber size (L x W)	410 x 460mm / 410 x 410mm 16 ¹ / ₄ x 18 ¹ / ₄ / 16 ¹ / ₄ x 16 ¹ / ₄	790 x 460mm / 710 x 550mm / 790 x 490mm 31 ¹ / ₄ x 18 ¹ / ₄ / 27 ¹ / ₄ x 21 ¹ / ₂ / 31 ¹ / ₄ x 19 ³ / ₄
Net sealing bar length	1 x 410mm / 2 x 410mm 1 x 16 ¹ / ₄ / 2 x 16 ¹ / ₄	2 x 790mm / 2 x 550mm / 1 x 790mm + 1 x 490mm 2 x 31 ¹ / ₄ / 2 x 21 ¹ / ₂ / 1 x 31 ¹ / ₄ + 1 x 19 ³ / ₄
Seal width "	8mm double seal 5 ¹ / ₈	8mm double seal 5 ¹ / ₈
Position of the sealing bar		
Voltage/phase/Frequency	230V/1 Ph/50 Hz	400V/3Ph/50 Hz
Pump capacity	21m ³ /h	100m ³ /h
Consumption	0.75 - 1.0 kW	3.0 - 5.0 kW
Number of gas pipes (optional)	2 per sealing bar	3 on short seal bar or 4 on long seal bar



Type 160



Type 300

Vacuum Chamber Machine Options

Gas Flushing - This gives a very low residual oxygen percentage by displacing the residual oxygen with an inert gas such as nitrogen after the initial vacuum has been formed then sealing once the desired volume of gas is reached. As a result the object is no longer under vacuum pressure.

Oxygen levels can be further reduced by the inclusion of oxygen scavengers.

Code Seal Security - Text can be imprinted in the seal area that may be useful to impart a message or the institution's name. The seal can be removed and locked away until the machine is next used. Also available for CXD Vacuum Impulse Sealer VIC 1000

Soft-air - Soft-air is the ideal function to enable fragile items to be packed without damage. The air enters the vacuum chamber very gently after the sealing process giving the vacuum bag time to form around the fragile or sharp product

Sensor - When it is important to obtain an exact level of vacuum or gas pressure CXD recommend the use of a sensor. The standard machine normally relies on a time cycle for the vacuum and gas levels, which is accurate enough for most applications. However, when dealing with products that vary in volume or density, a built-in sensor ensures that each package is under the same level of vacuum to ensure consistency of pressure.

Multi-cycles - Occasionally it may be necessary to have a repeated sequence of vacuuming and gassing. The multi-cycles option makes this possible with up to 8 processes in one cycle. It is not possible to combine the multi-cycle with the sensor option.

CXD Vacuum Impulse Sealer

Both sealing bars are heated and can be positioned vertically and horizontally with four positions in between, to suit the working position. The machine is supplied with a 5m³/hr vacuum pump and a water-discharge system and is mounted on wheels for manoeuvrability.

For operator safety when working with mouldy items the CXD VIC 1000 machines are fitted with a special fitting to allow the exhaust air to be carried by an exhaust pipe to a fume cupboard or outside the working area.

Technical Specifications

- Special exhaust fitting
- Seal length: 1000mm 39¹/₈"
- Seal width: 8mm 5¹/₁₆"
- Film thickness: 2 x 0.20mm 1¹/₆₄"
- Gas flush: Standard
- Consumption: 2400W
- Voltage: 230V / 50-60 Hz
- Dimension: 1240 x 590 x 1390mm 48¹³/₁₆ x 23¹⁵/₆₄ x 54²³/₃₂"
- Weight: 88kg

Product code	Description	Size mm	Size inches
EQSVIC1000	Vacuum Impulse Sealer VIC	1000	39 ¹ / ₈



Squelch Drying in progress



Mini Pro V-300-HTK

Conservation Vacuum Impulse Sealer

The XOX Mini Pro has been developed for CXD specifically for conservation storage, pest eradication and use with the Squelch Drying technique where the large capacity filter for waterlogged items and HEPA filter exhaust are unique features. The HEPA filter is important to protect the operator when working with water-damaged items which may have become mouldy. It prevents mould spores from being exhausted into the working area as is the case with standard food-packing machines. The gas-flushing facility may be unique for a machine of this size. In combination with oxygen scavengers it provides the ability to purge a storage bag with argon or nitrogen for use in pest irradiation treatments. Gas-flushing can be used for creating a sealed enclosure with minimum vacuum for the anoxic storage of delicate objects. It can also be used with controlled vacuum pressure when Squelch Drying a book to reduce compression on the binding and avoid distortion of the spine.

The XOX Mini Pro chamber-less, impulse sealer may be small but, by making overlapping welds, it is capable of producing and vacuum-sealing large bags. After inserting the object into the bag it is sealed leaving a small final seal to be done when the vacuum is created and the air is withdrawn. It is small and lightweight, making it easy to transport to where the work needs to be done. It can be carried by one person which is extremely useful at times of emergency.

Specifications

- Gas-flushing
- Large capacity filter for water
- HEPA filter at air exhaust port
- Voltage 230V
- Seal width: 10mm
- Seal length: two options
300mm or 400mm
- CE compliant

Product code	Description	Size mm	Size inches
EQVXOX0300	XOX Mini Pro	400	15 ⁷ / ₈



Vacuum-sealing Machine Comparison

Vacuum Impulse Sealers	Vacuum Chambers
Medium Level of vacuum attainable (up to 70%)*	High level of vacuum attainable (approx 98.8%)
Faster cycle time – only the pouch is vacuumed	Longer cycle time – entire chamber is vacuumed
Pouch size not limited by seal bar length if part sealed before vacuuming	Pouch size limited by chamber dimensions
Horizontal and vertical sealing	Horizontal or vertical sealing
Double-sided heating (bi-active) standard	Double-sided heating (bi-active) optional

*This can be increased with the use of oxygen scavengers.

 **Linked Products:** Low Barrier Bags p79; Archipress Pouches p80; RP p180; Oxygen Scavengers p180; KnoOx 1000 oxygen monitoring system. p184.

Disaster Response, Recovery and Prevention Products

Disaster Recovery and Prevention

Preserving precious artefacts brings with it a duty of care to be ready for all eventualities that can threaten to damage collections that have taken many generations to build and catalogue. Having the right equipment and products is paramount to being prepared.

React Pack Disaster Kit

A first-aid kit for small scale floods and leaks all contained in one lightweight fluted polypropylene box. The “don’t panic and who you gonna call” information is USA-based but it is helpful for non-US users as a template to produce a local version.



Product code	Description	Pack qty
SUREPA7053	React Pack Disaster Kit	1

The Prague Floods and Squelch Drying

In 1997 Stuart Welch invented a method of drying wet books and paper documents called Squelch Drying using a system of vacuum-packing. Following rapid support from the British Council the system is being used on a large scale to recover water-damaged books and documents from the Prague flood of 2002.



Identical Test Volumes, Prague: The book on the left was dried using the Squelch Drying technique, which gave better results than the freeze dried test shown on right.



Archipress™ vacuum-packing machine, in use for Squelch Drying flood-damaged materials.



Storage and drying books vacuum-packed with blotter/newspaper awaiting conservation studio in Prague.



Wet books grow mould quickly in warm conditions.

Sorbarix® A20 Water Absorbing Cushions

Sorbarix® A20 is a thin pillow which absorbs 23 litres of water or contaminated liquid in 180 seconds – the first 14-18 litres absorbed within 30 seconds. It provides extraordinary protection for the contents of Museums, Archives, Libraries and Heritage Buildings where it has generated a great deal of interest. In response to many requests, an independent laboratory has concluded its tests and confirmed Sorbarix® A20’s outstanding performance.

Product code	Description	Size mm	Pack qty
SUSBXA0020	Sorbarix® Absorbing Cushion - A20 Water	780 x 640 x 5	1

Applications (A20)

- Flooding, where they can be stacked to form a barrier to protect vulnerable areas
- Sprinkler deluge, where they can be placed over - and retain water from - valuable areas (temporarily or for an extended period)
- Any sort of water spills including accidents with humidifiers and fire extinguisher liquids

Linked Products: Vacuum Packing p168.

Sorbarix® AO8 Oil Absorbing Cushions

Sorbarix® AO8 is a small but highly effective lightweight pillow – 600 grams dry weight – which absorbs 8 litres of oil or oil-containing substances as soon as it is applied. The pillow acts quickly after being laid down and can be handled easily after use. The oil cushion is reusable up to 5 times. To re-use simply squeeze out the absorbed material. Like the Sorbarix® A20 water cushion, its size means it requires very little storage space and is easily transportable.

Product code	Description
SUSBXA0008	Sorbarix® Oil Absorbing Cushion
SUSBXA0020	Sorbarix® Water Absorbing Cushion



Humidity Control

Humidifier – LBV 45

This humidifier is for offices, walk-in humidors, museums and galleries or any area up to 350m³. Adjustable hygrosstat and swivelling diffusion screens. 30-litre tank offering great autonomy. Four wheels ensuring mobility. On/off indicator light. When the tank is empty the device shuts down automatically and a light indicator comes on.



Specifications

- Air capacity (at 21°C/30%rH): 45 L/24hor 1.87L/h
- Air flow: 500m³/h
- Power consumption: 70w
- Noise level: 32.5/42.8/47.1 decibels
- Tank capacity: 30 litres
- Dimensions (cm): 74 x 39 x 76
- Weight: 12.4kg

Product code	Description	Size mm	Size inches	Pack qty
EQHULV0045	Humidifier LBV45	500m ³ /h 740 x 390 x 760	1640ft 5 ³ / ₆₄ 29 ³ / ₆₄ x 15 ³ / ₆₄ x 29 ⁹ / ₆₄	1

Humidifier Defensor

This model has an excellent reputation and is used at many museums. It uses the principle of evaporation: the dry air comes into contact with the evaporation mat which is saturated with water, which it absorbs and spreads aseptically around the premises. The built-in hygrosstat ensures a regular humidity rate.



Specifications

- Air capacity (at 25°C/20%rH): 1.7 l/h
- Air flow: 340m³/h
- Hygrosstat and digital hygrometry display
- Four ventilation speeds from 155 to 340m³/h
- Maximum room capacity: 580m³
- Water tank capacity: 20 litres
- Power consumption: 72w
- Dimensions (cm): W73 x D37 x H61
- Weight: 25kg

Product code	Description	Pack qty
EQHUPH0015	Air Humidifier Defensor	1

Mini-dehumidifier

Mini-dehumidifier for a closed area of the showcase, cabinet or transportation crate type. Very small and light, it is made up of a plastic box containing Hydrum crystals.

It is capable of absorbing a large amount of humidity. At saturation (the colour level can be seen on the device), all that is required is to connect the device to a mains socket for around ten hours until the marker turns blue. The device is then recharged and is ready to perform its dehumidification functions again.



Product code	Size mm	Size inches	Pack qty
SUPRCS0009	120 x 150 x 40	4 ²³ / ₃₂ x 5 ²⁹ / ₃₂ x 1 ³⁷ / ₆₄	1

Dehumidifier – Edenair

Edenair devices are sturdy and powerful. Over many years they have shown their effectiveness in archives and other sensitive premises. Patented optimised exchange battery, made up of tubes with copper fins, fully tin-plated. Automatic defrosting by hot gas as standard. Condensed water flows into the built-in container or can be connected to the drainage system. Dried air reheated by the condenser. Precision regulation hygrosstat. Mounted on wheels or fixed. Mobile or fixed dehumidifier – T750 model.



Specifications

- Air flow processed: 300m³/h
- Refrigerating capacity at 30°C and 80% RH: 870 W
- Air filter efficiency: 50%
- Tank volume: 10-litre
- Condensed water output Ø16mm
- Operating limits: 5 to 35°C
- Dimensions (cm): W42 x D41 x H65
- Weight: 38kg

Product code	Description	Pack qty
EODHEA0750	Dehumidifier	1

Dehumidifier Narcisco 16

The Narcisco 16 dehumidifier has the capacity of 3.5-litre water tank. It has an automatic shut-off when the tank is full and a warning light will indicate when the tank needs to be emptied; alternatively the dehumidifier can be used with continuous drainage (hose not supplied).



The dehumidifier does this by turning the compressor off; the fans however will continue to run, drawing ambient air over the coils, thus melting any built-up ice. This allows the dehumidifier to operate at temperatures as low as 10°C.

Specifications

- Dimensions (cm): W41 x D29 x H63
- Weight: 16kg
- Noise level: 45 decibels (measured at 1m distance)
- Extraction: 8L at 27°C/60%rh, 16L at 30°C/80%rh
- Tank capacity: 3.5 litres
- Continuous drainage hose size: 13mm inner diameter
- Operating temperature: 10°C - 35°C
- Power consumption: 300w
- Air circulation: 180m³/h

Product code	Description	Pack qty
EQDES0016	Dehumidifier Narcisco 16	1

Dehumidifier – OD125/165

These rugged, low-temperature units are robust, built to withstand commercial use, and perfect for residential use where long-lasting dependability is a must. Frost-free system enables operation in ambient temperatures as low as 5°C, with operation range up to 36°C. Automatic Humidistat Control automatically turns unit ON or OFF at pre-selected moisture levels.



Specifications

- OD 125/165 model
- Product code Description
- DESOD125 Humidifier OD125
- DESOD165 Humidifier OD165
- OD125 OD165
- Power consumption: 370w 480w
- Dimensions cm: W38 x D36.2 x H60.5 W38 x D36.2 x H60.5
- Air flow: 425m³/h 510m³/h
- Extraction capacity (at 30°C/80%)
- 22.4L/24h 27.2L/24h
- Maximum room capacity: 500m³ 600m³
- Operating temperature 5°-36°C 5°-36°C
- Noise level (measured at 1m distance)
- 45 decibels 55 decibels
- Weight: 22.7kg 23.5kg

Product code	Description	Size m	Size inches	Pack qty
EODES00125	Dehumidifier OD125	425m ³ /h 510m ³ /h	1394ft ⁴ / ₃₂ 1673ft ² / ₆₄	1
EODES0165	Dehumidifier OD165	500m ³ 600m ³	1640ft ⁵ / ₆₄ 1968ft ⁶ / ₆₄	1

Dehumidifier – WELLDRY 20 Model

The Air and Water Centre recommends the use of this dehumidifier for professional use including drying flooded buildings and new builds.

This dehumidifier has the capacity of a 10-litre water tank. It has an automatic shut-off feature when the tank is full and an alarm indicator on the front panel will illuminate from blue to red. The tank can be emptied manually or set up for permanent drainage.



Specifications

- Dimensions (cm): W40 x D31 x H54
- Voltage: 230V/50Hz
- Power consumption: 560w
- Air circulation: 240m³/h
- Recommended room size: 120m²
- Operation noise level: 47 decibels
- Dehumidification performance: 20l/day @ 27°C and 60%
- Operational temperature: 5°C-35°C
- Water tank: 10 litres
- Weight: 23kg

Product code	Description	Size m	Size inches	Pack qty
EODEWE0020	Dehumidifier WELLDRY20	240m ³ /h	787ft ⁴ / ₃₂	1

PROSorb™ Humidity Control Systems

PROSorb™ is a new silica gel ideally suited to stabilise relative humidity inside museum display cases and storage cabinets.

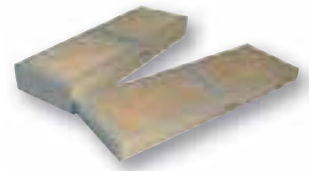

The ideal level of humidity for most museum display cases and storage cabinets is a level between 40 and 60% RH (Relative Humidity). PROSorb™ has a unique and exceptional absorption capacity within the 40-60% RH range. It is able to maintain a stable RH within narrow margins through its ability to both absorb and desorb water vapour; and is provided preconditioned to your desired humidity level. PROSorb™ also has a longer life span than other silica gels. Available as beads, full and half-size cassettes.

Product code	Description	Pack qty
SUPRCS1340	PROSorb™ Half-size Cassettes. 40%	1
SUPRCS1345	PROSorb™ Half-size Cassettes. 45%	1
SUPRCS1350	PROSorb™ Half-size Cassettes. 50%	1
SUPRCS1355	PROSorb™ Half-size Cassettes. 55%	1
SUPRCS1360	PROSorb™ Half-size Cassettes. 60%	1
SUPRCS1440	PROSorb™ Full-size Cassettes. 40%	1
SUPRCS1445	PROSorb™ Full-size Cassettes. 45%	1
SUPRCS1450	PROSorb™ Full-size Cassettes. 50%	1
SUPRCS1455	PROSorb™ Full-size Cassettes. 55%	1
SUPRCS1460	PROSorb™ Full-size Cassettes. 60%	1
SUPRCS1540	PROSorb™ Sachet, 500g. 40%	1
SUPRCS1545	PROSorb™ Sachet, 500g. 45%	1
SUPRCS1550	PROSorb™ Sachet, 500g. 50%	1
SUPRCS1555	PROSorb™ Sachet, 500g. 55%	1
SUPRCS1560	PROSorb™ Sachet, 500g. 60%	1
SUPSBD1040	PROSorb™ Humidity Control, Beads 40%	1
SUPSBD1045	PROSorb™ Humidity Control, Beads 45%	1
SUPSBD1050	PROSorb™ Humidity Control, Beads 50%	1
SUPSBD1055	PROSorb™ Humidity Control, Beads 55%	1
SUPSBD1060	PROSorb™ Humidity Control, Beads 60%	1
SUPRCS1640	PROSorb™ Sachet, 800kg. 40%	1
SUPRCS1645	PROSorb™ Sachet, 800kg. 45%	1
SUPRCS1650	PROSorb™ Sachet, 800kg. 50%	1
SUPRCS1655	PROSorb™ Sachet, 800kg. 55%	1
SUPRCS1660	PROSorb™ Sachet, 800kg. 60%	1

Metal Presentation Boxes for PROSorb™ Pellets

Container boxes made of perforated stainless steel. They can hold PROSorb® pellets, the air exchange being carried out thanks to the multiple perforations.



Highly practical, they can be easily recharged and laid out in a showcase or a crate when objets d'art are being transferred thus providing good hygrometric balance.

Product code	Description	Size mm	Pack qty
SUPRCS0007	PROSorb™ Metal Storage Box	165 x 64 x 25	1
SUPRCS0008	PROSorb™ Metal Storage Box	330 x 114 x 38	1

Artsorb® Sheets

Fine particles of Artsorb® trapped between sheets of non-woven synthetic fabric, Artsorb® sheets have a large moisture capacity and offer an efficient response to changes in external relative humidity. 100 g dry gel/sheet, preconditioned at 50%. Artsorb® Sheets are ideal for use in a picture frame or tight spaces in a showcase. Requires about 5-10 sheets per cubic metre volume of air in display case.



Product code	Description	Size mm	Size inches	Pack qty
SUARTS0500	Artsorb® Sheet	500 x 500 x 1.8	20 x 20 x 0 ³ / ₆₄	1

Orange – Silica Gel

Orange to dark green (when saturated) Silica Gel beads have a more obvious colour change than previously available for improved application in the display environment. Impregnated with an organic indicator (0.2% methyl violet) they are also non-hazardous.



Product code	Description	Weight	Pack qty
SUSIL10001	Orange Self-indicating Silica Gel	5g	10
SUSIL10002	Orange Self-indicating Silica Gel	25g	10
SUSIL10003	Orange Self-indicating Silica Gel	1kg	1

Bozone Sorb

Bozone Sorb is an environmentally friendly humidity regulator that uses natural minerals which provide excellent absorption performance. Conditioned to maintain humidity between 50% - 60%. To inspect when replacements are required the Bozone Sorb is offered in a cassette with viewing panes.

Specifications

- Maintenance of optimal humidity suitable for cultural assets and records
- Maintenance of humidity suitable for the characteristics of different materials.
- Maintenance of humidity at 50%-60% as recommended for paper, books, paintings, textiles, wood and other organic objects.
- Maintenance of humidity at 40% as recommended for photographs, iron/steel and ceramic objects.

Applications

- Filing cabinet, storage closed of relics, preservation boxes
- Show case, storage
- Other places where the maintenance of constant humidity is needed

Product code	Description	Pack qty
EQBZSB0001	Bozone Sorb	1 Pair

Testing Indicators

Humidity Indicator Cards

Small, inexpensive and easily portable cards for giving approximate humidity readings. The cards are made from a Cobalt Chloride impregnated blotter divided into nine sections which exhibit various colours from blue through lavender to pink. The position of the lavender section indicates the relative humidity of the surrounding air. These can be used with Escal Neo™ and PTS Bags as a long-term check against punctures and the ingress of moisture.



Product code	Description	Size mm	Size inches	Pack qty
SUCARD0020	Humidity Indicator Cards	38 x 108	1 1/2 x 4 1/4	10

Blue Wool Scales/Fade Indicator Card

Blue Wool Scale Cards go from 8 to 1 and are used to measure light-fastness or monitor the net exposure to light given to objects on display. Blue wool 8. indicates excellent light-fastness.

Blue wool 1. indicates fugitive very poor light-fastness.

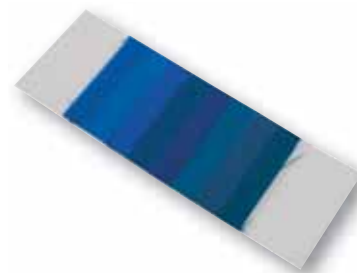

Product code	Description	Size mm	Size inches	Pack qty
SUBWSC7176	Blue Wool Scales	127 x 51	5 x 2	1



Iron-Gall Ink Testing Paper

This non-bleeding iron test paper has been developed by the Conservation Research Department at the Netherlands Institute for Cultural Heritage/ Instituut Collectie Nederland as a simple and quick method to detect iron (II) ions in hydrophilic substrates. Iron ions are harmful to organic substrates like paper, because they catalyse the oxidative degradation of cellulose and other organic materials. The test paper is non-bleeding, so it can be applied to originals. Iron-Gall Ink Testing Paper has been extensively tested in paper conservation. In general a positive reaction of the iron (II) test is a distinct identification of the presence of an iron-gall ink. However, it has to be realised that other inks and colourants, eg bistre, may be iron-based or contaminated with iron.



Iron (II) ions are water-soluble and will migrate into a dampened test paper in contact with the ink. The indicator (bathophenanthroline) forms an intensely red-coloured complex with iron (II) ions. Instructions are provided with the test papers.

Product code	Description	Size mm	Pack qty
SUIGIT3000	Iron-Gall Ink Test Paper	75 x 10	1

LightControl



LightControl is an indicator comprising a blue compound that exhibits a progressive and non-reversible colour change while exposed to light. It acts as an early warning system for light-sensitive objects. When the indicator colour turns from blue to purple, the yearly display allowance has been spent, meaning that the object has been exposed to the maximum amount of light recommended by art experts. If the indicator keeps its blue colour over a one-year period (or more), the lighting conditions comply with international museum recommendations and can be considered safe for the artefact. This does not mean that the object will not deteriorate at all from exposure to light; instead it indicates that the degradation from light will be gradual enough to not be noticeable for a century or more.

Product code	Description
EQLTCT0005	LightControl Pack of 5 cards

Dancheck Film Indicators

For monitoring the condition of acetate and nitrate film.

Film archives throughout the world are fighting against time in a desperate attempt to preserve their collections. In the first half of the 20th century nitrate film became explosive and now colour fading and 'Vinegar Syndrome' are problems for acetate films.

The Dancheck 24-hour pH Indicator Strip is a piece of dyed filter paper, 10 x 40mm. It is a very sensitive indicator and will sense 'Vinegar Syndrome' when in contact with film. The colour is blue when fresh in the pouch, changing to pale yellow when exposed to an acid environment. There is a small bag in the pouch filled with silica doped with a strong alkaline to preserve the colour until needed and it is important to squeeze all the air from the pouch each time the indicators are used.



Dancheck pH Monitor Window fits into the side of a film can or box and monitors the atmosphere within for any signs of acetic acid.



Blue Dancheck Film pH Indicator Eye fitted into a film can.

The Dancheck Acetate pH Monitor can sense degrading films long before vinegar is smelt. If the Dancheck Monitor shows light green – pH4.6 the film has probably reached the autocatalytic point and duplication of the film should be considered. The monitors are light-sensitive and should be treated with care. Keep them in a bag in the dark until needed.

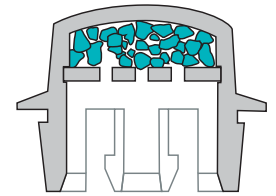

METHOD: Place the Dancheck pH monitor filter paper on the film (with gloves) and start the stopwatch. The strip test takes two hours and is a very accurate way of testing a film. Tests are performed at room temperature. If the colour changes to olive green you have reached the critical autocatalytic point, which is the point when you should consider separating the film from the rest of the collection and schedule the film's duplication. If the indicator strip has not reacted within 24 hours there is nothing critically wrong and the film may be stored in the vault. Do not leave the indicator in the open air because it will fade within 24 hours.

The Dancheck Acetate Film pH Monitor Window clips into an 11mm hole for which a special film can punch can be supplied.

Dancheck Film Can pH Monitors could also be used in Boxes and Storage Drawers by drilling an 11mm hole.

Product code	Description	Size mm	Pack qty
SUDCIS1040	Dancheck Indicator Strip	10 x 40	250
SUDCIS1020	Dancheck 2 Hour Acidity Strip	10 x 20	500



Environmental Monitoring

As everyone knows, paper works and documents are usually very fragile. To preserve them in the best possible condition for as long as possible, the people responsible for looking after them must use inspections apparatus to check that storage or exhibition conditions conform to the prevailing standards.

It is important to monitor the relative humidity (RH) of archiving premises: Too high relative humidity (+ 60%) accelerates the chemical and biological deterioration of the materials, too low relative humidity (- 20%) dries the paper which becomes fragile when handled, variation in RH causes the paper to deform.

For graphical works on paper, we recommend a RH level of around 50% at a temperature in the region of 18°C (photographic documents require lower values). Unfortunately, this is not always possible.

Although certain values are admissible, above all it is important to avoid excessive, sudden fluctuations which accelerate the deterioration of the paper.

Humidity and Temperature Measurement

Testo Saveris™ 

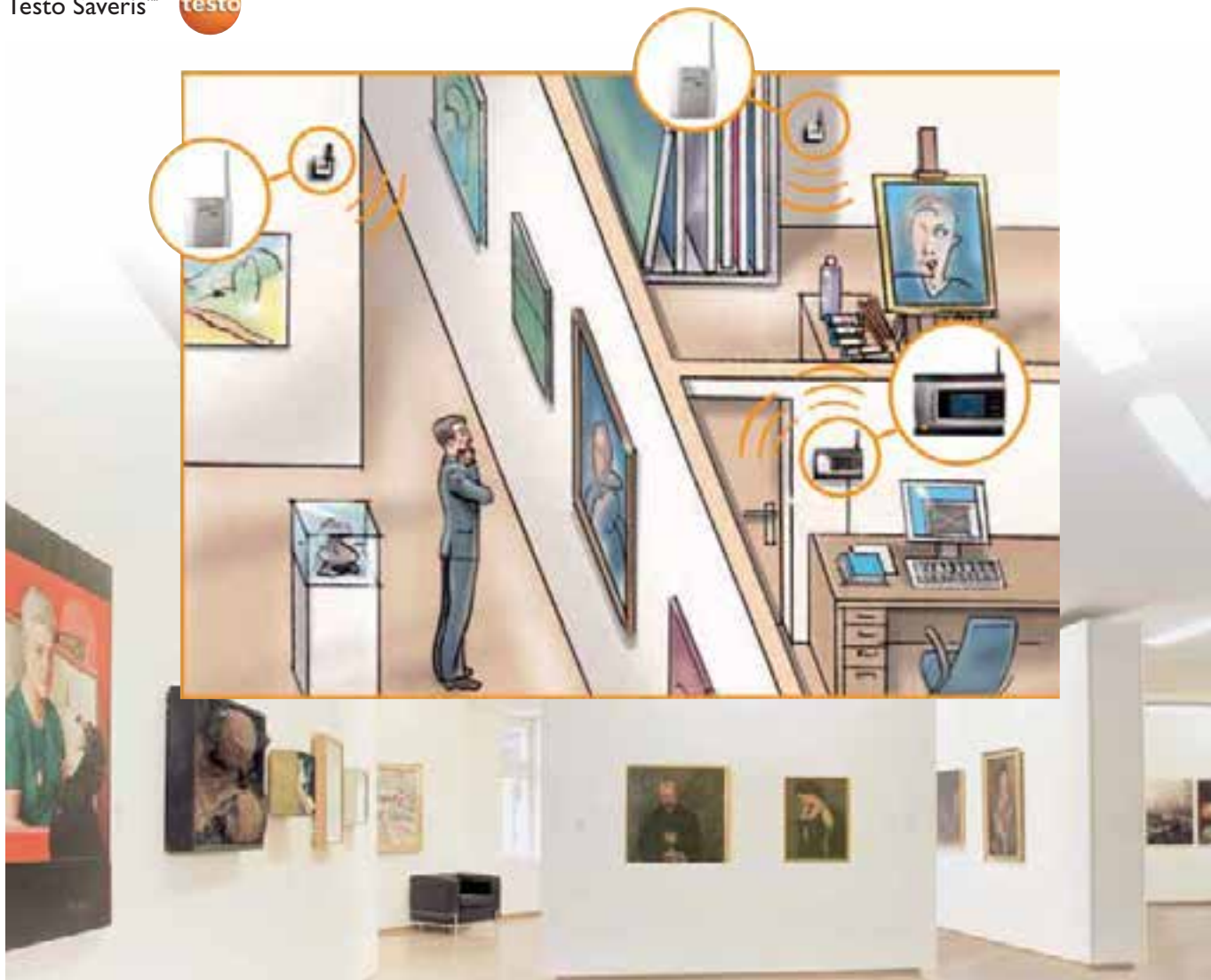

The Testo Saveris™ radio probes measure temperature and humidity. In the measuring cycle, the probes save the recorded measurement data and send it to the central base at regular intervals. If a limit value is exceeded, a radio link is established immediately. Through bidirectional transmission, the radio probe and the base are in mutual contact. This therefore ensures that the measurement data is only recorded by the base and is not interfered with by other radio systems.

An alarm sounds in the event that the radio link be interrupted by obstacles. The memory in the probe ensures that the measurement data is not lost in the event of an interference in the radio link. An optimised battery design ensures for long running life of the probe memory.

In free field, the transmission path is approx. 300m at a frequency of 868MHz and approx. 100m at a frequency of 2.4GHz. In buildings, the transmission path is strongly influenced by structural conditions such as walls, refrigerator doors or metal doors. The radio link can be improved or lengthened with poor structural conditions by using a router. Because the radio probe and the router show the quality of their radio link, the probe can be positioned optimally by the user.

Probe versions with internal and external sensors allow the adaptation to every application. The radio probes are available with or without a display as an option. Current measurement data, the battery status and the quality of the radio link are shown on the display.

Testo Saveris™

Testo Saveris™ Base

The base is the heart of Testo Saveris™ and can save 40,000 readings per measurement channel independent of the PC. This corresponds to around one year of memory capacity at a measuring rate of 15 minutes. An emergency battery ensures that an alarm is transmitted and that no existing data is lost in the event of a power failure. The system data and alarms are visible via the display of the Saveris base. Even without the PC running, the base issues an alarm by means of an LED if the limit value is exceeded, or optionally via SMS and via a relay output to which an alarm transmitter can be connected. In total, a base can incorporate 150 radio and Ethernet probes or 254 measurement channels. The Saveris base is connected to the PC either via USB or Ethernet cable. The Saveris base thereby offers flexibility with the highest data security.



Specifications

- Memory: 40,000 values per channel (total max. 10,160,000 values)
- Display for showing alarms and system data
- Power supply (absolutely necessary) : 6.3V DC mains unit; alternatively via 24V AC/DC plug-in/screw terminals, power consumption < 4W
- Rech. batt.: Li-ion battery (for data back-up and for emergency SMS with failure of the power supply)
- Alarm relay max. 1 A, max. 30W, max. 60/25V DC/AC, NC or NO contact
- Up to 150 probes can be connected

Product code	Description
EQTSBA0001	Saveris base - 868MHz
EQTSBA0002	Saveris base - 868MHz - GMS module (to send SMS)
EQTSR00001	Mains unit for base or router

Testo Saveris™ Logiciel

The measurement data is transmitted from the base to a PC on which the Testo Saveris™ software is installed within just a few minutes using an installation wizard. The initial system and probe configuration is also performed using the software.

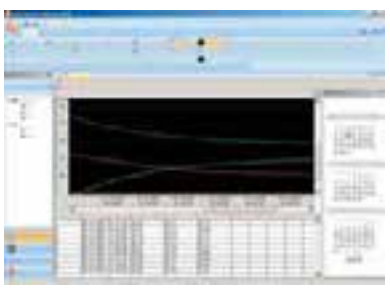

All measurements are saved centrally in the software's database and can be called up any time as a table or a graphic. All alarms that occur are listed in a table as a history. The automatic creation of PDF reports in defined intervals also simplifies the documentation. Using the calendar function and the consolidation of probes into groups, the operation of the software is simple and intuitive. In the event of an alarm the user can choose between receiving a message via email or a pop-up directly on the screen.

	SBE	PROF
Simple installation and configuration	•	•
Diagrams/tables/alarm overview/PDF reports	•	•
Calendar management	•	•
Representation of probe group	•	•
Transmission of alarms (email, SMS, relay)	•	•
Comprehensive alarm management		•
Constant monitoring in PC continuous operation		•

Product code	Description
EQTSLS0001	Software SBE supplied with USB cable
EQTSLP0001	Software PROF supplied with USB cable

Testo Saveris™ Router

The radio link can be improved or lengthened with poor structural conditions by using a router. Naturally several routers are possible in the Testo Saveris™ system, but several routers are not connected in series.



Specifications

- Dimensions: Approx. 85 x 100 x 38mm
- Weight: Approx. 180g
- Power supply: 6.3V DC mains unit; alternatively via 24V AC/DC plug-in/screw terminals, power consumption < 0.5W
- Protection class: IP54
- Connectable radio probe: max. 5
- Wall bracket: included

Product code	Description
EQTSR00001	Testo Saveris™ router - 868MHz
EQTSBL0001	Mains unit for base or router

Testo Saveris™ Radio probes T° and HR

Specifications

- Dimensions: Approx. 80 x 85 x 38mm
- Weight: Approx. 240g
- Battery type: 4 AA batteries
- Measure range: -20 to +50°C, 0 to 100% HR
- Resolution: 0.1°C, 0.1% HR
- Accuracy: ±0.5°C, ±3%RH
- Wall bracket: included



Product code	Description
EQTSHT0001	Radio probe H3 with display
EQTSHT0002	Radio probe H3 without display

Testo Saveris™ Radio probes T°

Specifications

- Dimensions: Approx. 80 x 85 x 38mm
- Weight: Approx. 240g
- Battery type: 4 AA batteries
- Measure range: -35 to +50°C
- Resolution: 0.1°C
- Accuracy: ±0.4°C(-25°C à +50°C), ±0.8°C(remaining range),
- Wall bracket: included



Product code	Description
EQTSTT0001	Radio probe T1 with display
EQTSTT0002	Radio probe T1 without display

Thermidity™

CXD Thermidity™ loggers are ideal for temporary exhibitions, for tracking conditions within shipments of sensitive documents or objects or situations where a wired or radio system is not the best solution. The internal memory will allow readings to be taken in 10-minute intervals for 12 months before needing to be downloaded, via a convenient USB connection and easy-to-use software. The software includes powerful reporting tools and allows data to be displayed in numerous formats or exported to Microsoft Excel®.



The CXD Thermidity™ logger incorporates a precision thermistor suitable for use from -24°C to 66°C and humidity sensor which operates between 0-100% RH (non-condensing) within a small (105 x 65 x 19mm), discreet and durable ABS plastic case.

Product code	Description	Pack qty
EQHTDL1000	CXD Thermidity™	1
EQRHDO200	Thermidity™ RH-T Datalogger Software	1
EQHDLCO055	Thermidity™ RH-T USB Cable	1

Paper Sword Moisture Monitor

Specifically designed for the measurement of humidity and temperature within stacks of paper, cardboard or any other cut sheet material. The robust yet lightweight design and refined electronics makes the device easy to use with a single button whilst providing reliable readings. The package includes the Sword Moisture Meter, carry case, calibration device, 5 ampoules 50% RH with SCS certificate and adjustment screwdriver.



Specifications

Range:

20.0 to 95.0% RH

0.0 to 60.0°C / 32.0 to 140.0°C *

Dew Point -20.0 to 60.0°C / -4.0 to 140.0°F

Resolution:

0.1 % RH / 0.1°C / 0.1°F

0.1°C / 0.1°F

Accuracy:

±3 % RH (50 to 85% RH and 15 to 40°C)

±5% RH (outside)

±0.5°C / ±1°F

±2°C / ±4°C (50 to 85% RH and 15 to 40°C);

±4.5°C / ±9°C (outside)

Battery Type: 1 x 9V alkaline (IEC 6LR61)

Battery Life: 250 hours of continuous use

Environment: 0 to 60°C (32 to 122°F); 98% RH non-condensing

Dimensions:

164 x 76 x 45mm (6.5 x 3.0 x 1.8")

Weight: 340g (12oz)

* Note: The meter measures temperature from -30 to 80°C, but the RH measurement can only be taken within the range 0 to 60°C.

Product code	Description	Pack qty
EQSMMS0050	Sword Moisture Meter with 50% RH Standard	1

Elssec 765/7650

Well-trusted hand sized Elssec monitoring instruments that use solid-state sensors for accurate, drift-free operation. The 764 model effectively monitors ultraviolet and visible light (lux or foot-candles), % relative humidity, dew point and temperature in either °C or °F. Features an easy-to-read display and simple-to-use function keys meaning this unit can be picked up and used with no training.



Elssec 7650 is similar to the 765 but without the added humidity and temperature for those only interested in light and UV.

Product code	Description	Pack qty
EQLSDL0765	Elssec 765 – Humidity, Temperature, Light and UV	1
EQLSDL7650	Elssec 7650 – Light and UV	1

LOG-HC2 Universal Data-Logger

The rugged and compact data-logger measures and records temperature, humidity, air pressure, illuminance and 3-axis acceleration/ position simultaneously. The 3-axis acceleration measurement can be used to identify if/when there has been movement, including when a packaged object is dropped during transportation. This combination of measurements within a data-logger with a housing designed for mounting into cabinets, industrial rails etc, makes this a perfect device for use when transporting valuable artwork or objects.



A four-line LCD with backlight and a rechargeable battery ensures maximum performance combined with high ease of use. For mounting in switch cabinets and industrial environments, the logger can be attached to a DIN top-hat rail.

This device can also be used in conjunction with Rotronic interchangeable Miniature and Flush Mount probes for use in CXD Museum Showcases, or other applications where precise, unobtrusive measurement and logging are required. Please contact CXD for more information.

Features

- 2,000,000 data point memory
- Operating range of electronics (the measurement range is probe dependent) -20...65 °C, 0...95 % RH
- Power supply: rechargeable lithium polymer battery with 2,300 mAh for long-term recording, chargeable via USB cable or mains power adapter
- PC software for data evaluation and logger configuration
- Typical battery life: 535 days
 - Logging interval: 1s - 12h
 - Measured parameters: 2 x humidity and temperature, air pressure, light and axis acceleration
- Dimensions: 61 x 77 x 36mm

Product code	Description	Pack qty
EQEMHC2001	Universal Logger	1
EQEMHC2002	HCS-2 Temperature and Humidity Probe	1

HygroPalm 22-A Set

The HygroPalm22-A Set with interchangeable probe input is ideal for numerous applications where precise measurement is required. This set includes a probe for the measurement of temperature and humidity, calibration device, 50% RH calibration standards, extension cable and carrying case.

This device can also be used in conjunction with Rotronic interchangeable Miniature and Flush Mount probes for use in CXD Museum Showcases, or other applications where precise, unobtrusive measurement and logging are required. Please contact CXD for more information.



Product code	Description	Pack qty
EQEMHP2200	HygroPalm 22-A Set	4

Flush Mount Probes

Offering high accuracy measurement of temperature and humidity with minimal intrusion due to the low profile of the probes. These flush-mounted probes provide a perfect balance between monitoring the environmental conditions within museum showcases, frames or other display units and the need to keep the document or object the focus of visitor attention.



Mounted with simple 3/4"-G thread, which allows a Ø32mm 'flat probe', protruding by approximately 3mm which can be fitted to the HP22-A Set handheld device, or the LOG-HC2 Universal Data-Logger.

Alternatively, these probes can be connected to wireless transmitters and the data incorporated into a data acquisition system using HW4 software.

Product code	Description	Pack qty
EQEMIP2501	Polyethylene filter, with 2m cable	1
EQEMIS2502	Sintered steel filter, with 2m cable	1
EQEMIT2503	Teflon® filter, with 2m cable	1

Miniature Probes

Accurate and unobtrusive the Ø4mm and Ø5mm miniature probes are used for humidity and temperature measurement in confined spaces such as the CXD Museum Showcases, Planorama® Display Cabinets and Humidity Controlled Framorama™. The discreet probes are available in two sizes; Ø4mm x 57mm length and Ø5mm x 51mm. Both miniature probes are mounted on 2m of cable, and can be fitted to the HP22-A Set handheld device, or the LOG-HC2 Universal Data-Logger.



Alternatively, these probes can be connected to wireless transmitters and the data incorporated into a data acquisition system using HW4 software.

Product code	Description	Pack qty
EQEMHC2574	HC2-C04, with 2m cable	1
EQEMHC2515	HC2-C05, with 2m cable	1

Tiny Tag Ultra 2 (Dual Channel)

Tiny Tag Ultra miniature recorder. This recorder with an internal sensor allows you to monitor the temperature and the humidity of exhibition areas or showcases, storage areas in libraries and archives. Small, with an ergonomic design, you simply place it inside a showcase or on a shelf or hang it on a wall. Its memory can contain 7900 measurements for up to three months worth of recordings programmed at 15-minute intervals. The readings sensed are made via a PC, where the information is exploited by the OTLM software application which runs in Windows.

You simply have to take the Tiny Tag recorder and connect it to the PC using the supplied cable. The exploitation of the data is carried out in the form of curves where it is possible to obtain a comparative display of the measurements from various different sensors.

The starter kit comprises one TGUI500 sensor, the PC connection cable and the OTLM exploitation software application. The simultaneous thermo-hygrometric monitoring of a number of areas (eg several exhibition halls) requires as many sensors as there are areas to be monitored. Tiny Tag Ultra is designed to be used with a PC (4Mb RAM, 3Mb free hard disk space – running Windows 3 minimum).

The configuration and the start-up of the recording is managed very simply by the OTLM software application which has the following features: definition of the scanning interval and the shutdown mode, programming of delayed start-up, configuration of alarms, reading and exploitation of the data from the recorder: zoom functions, statistics windows, etc. manually start and stop recording, data export to a spreadsheet (Excel, Lotus) in the form of a text file.

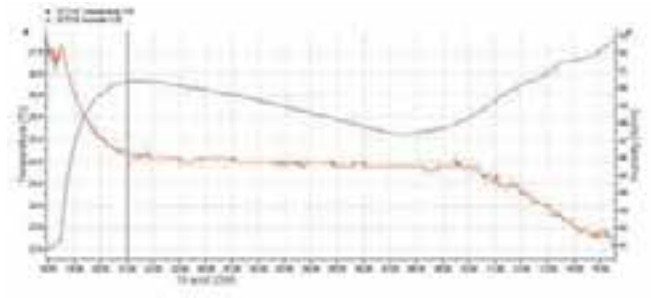

Product code	Description
EQTINV0002	Data Recorder only
EQTINV4500	Recorder + Software + USB
EQTINV0001	USB cable

Tinyview Plus

Temperature and RH recorder (-30 to +50°C, 1 to 100% RH). This recorder sensor has an LCD screen which displays the temperature, humidity and alarm conditions instantly. The data can be exploited using the Tinytag Explorer software application running in Windows.



Small format (less than 90mm overall size), light (85g), discreet (light grey), it fits naturally into enclosed spaces such as exhibition display cases in museums, archives and libraries. It allows you to monitor the thermo-hygrometry.

Specifications

- Capacity: 30,000 readings. Programmable polling intervals 2 alarm programs. Programmable delayed start 3 shutdown options. Manages minimums and maximums polling interval 1 sec to 10 days.
- Lithium battery temperature: -30 to + 50°C resolution: 0.5°C humidity: 0 to 100% RH.
- Capacitive type sensor resolution: 0.5% RH sensor accuracy: +/- 3% at 25°C
- Starter kit comprises:
 - 1 sensor REF:TV1501 + PC serial port connecting cable + Tinytag Explorer software application.
- Optional extras:
 - Additional sensor
 - USB connecting cable

Product code	Description	Pack qty
EQTINY0003	Data Recorder only	1
EQTINY4501	RHT Data-Logging Kit comprises Recorder + Software + USB	1
EQTINY0001	USB cable	1

Tinytag Thermo-Hygrometer

This light, handy thermo-hygrometer allows you to take humidity and temperature measurements when required. The data is displayed on the LCD screen. The special feature offered by the Tinytag thermo-hygrometer is that it can be used as a genuine data centre which can be run on a Windows PC using the Tinytag Explorer software application (supplied as standard).



Specifications

- Reading capacity: 32,000
- Operates from -20 to + 50°C and from 1 to 100% HR
- Can operate either alone or as a recorder of data exploitable with the Tinytag Explorer software application
- Measures the temperature and the relative humidity battery low indicator
- Runs on 2 standard AA LR6 batteries. Shipped with the Tinytag Explorer software application 1 PC serial port cable
- Optional: USB cable

Product code	Description	Pack qty
EQTINY2500	Device	1
EQTINY0004	Software and USB cable	1

Testo 174H Mini Data-Logger, Dual-Channel

The mini data-logger for temperature and humidity, Testo 174H, is ideal for monitoring temperature and humidity sensitive goods in storage. The Testo 174H also monitors building climate, continuously, securely and unobtrusively. The free software ComSoft Testo 174 allows fast programming of the data-logger and easy analysis.

- Humidity sensor with long-term stability
- High data integrity, even with empty battery
- Large measurement data memory
- Display of the current temperature or humidity value
- Large measuring range
- Compact and robust
- Issue of alarms via display
- Data transfer to the PC via USB interface



Product code	Description	Pack qty
EQTINY0003	Data Recorder only	1
EQTINY4501	RHT Data-Logging Kit comprises Recorder + Software + USB	1
EQTINY0001	USB cable	1

CL11 Indoor Air Quality Data-Logger

This benchtop data display and logging unit is ideal for use in temporary exhibitions or galleries wishing to be able to easily view the current, maximum, minimum and average air-quality data whilst also recording measurements for later analysis. Can be wall-mounted.



Features

- Simultaneously records humidity, temperature and CO₂
- 40,000 data point memory
- Maximum, minimum and average values displayed
- Adjustable audible and visual CO₂ alarm
- Clock
- Optional external temperature probe
- Includes software for configuration and data download
- Mini USB interface

Product code	Description	Pack qty
EQEMCL3101	CL11 Indoor Air Quality Monitor	1
EQEMCL3102	Mains adapter (optional)	1

Testo 175HI, Dual-Channel Temperature and Humidity Data-Logger

With its long-term stable humidity sensor, the Testo 175HI is the professional data-logger for the monitoring of temperature and relative humidity in work and storage rooms. The external probe (stump) stands out thanks to faster reaction times in comparison to probes installed inside the housing. Energy savings are an important topic for buildings.

However, better external insulation and new, energy-efficient windows can also have undesired side effects. With the targeted reduction of natural ventilation, this means more heat is retained in the building but also more humidity is generated by the inhabitants! In badly ventilated places there is therefore the danger of mould growth. The Testo 175HI continuously records temperature and humidity values and shows the dewpoint in the display. The indoor climate is thus monitored, emphasising the need for targeted ventilation and air exchange. The 175TI is a simplified version; it's smaller, and just has a temperature sensor.

Professional long-term monitoring of temperature and humidity in work and storage rooms.

Fast reaction time, thanks to external humidity probe.



Specification

Description	175HI	175TI
Memory	1.000.000 readings	1.000.000 readings
Stockage temperature	-35 ... +55°C	-35 ... +55°C
Operating temperature	-35 ... +55°C	-35 ... +55°C
Dimensions	149 x 53 x 27mm <small>5 7/8 x 2 1/2 x 1 1/8 inches</small>	89 x 53 x 27mm <small>3 1/2 x 2 1/2 x 1 1/8</small>
Probe type T°:		
Measure range	-35 ... +55°C	-35 ... +55°C
Accuracy	±0.4°C (-20 ... +55°C)	±0.5°C (-20 ... +55°C)
Resolution	0.1°C	0.1°C
Probe type HR:		
Measure range	0 ... 100% HR	-
Accuracy	±2% HR (2 ... 98% HR)	
+0.03% HR/K	-	
Resolution	0.1% HR	-

Product code	Description m	Pack qty
EQENTT1751	Temperature and Humidity	1
EQENTT1752	Temperature	1
EQENTT1753	4Gb Memory card for Testo 175	1
EQENTT1754	USB Cable for Testo 175	1

Thermo-hygrometer

Ideal for display cases, storage shelves, archiving boxes and more!



- Bi-metallic method for higher accuracy
- Mechanical design – recalibration possible
- Compact size (dimensions: 48mm x 28mm x 14mm)
- Temperature measurement accuracy: ± 1°C
- RH measurement accuracy: ± 5%
- No battery needed

Product code	Size mm	Size inches	Pack qty
EQJCTH0001	48 x 28 x 14	1 7/8 x 1 1/4 x 3/8	1

Testo Infrared Thermometer – Laser Sighting and Integrated NTC Air Measurement

Infrared measurement with I-point laser sighting and 6:1 optics ratio. Display of differential temperature, eg between a window surface and ambient air. Hold function and min/max. values. Including wrist strap and belt clip.



Dimensions: 119 x 46 x 25mm.

Specifications

Probe type Infrared:

- Measure range: -30 to 300°C
- Resolution: 0.1°C
- Accuracy: ±2°C (-30°C to +100°C), ±2% (remaining range)

Probe type NTC:

- Measure range: 10 to 50°C
- Resolution: 0.1°C
- Accuracy: ±0.5°C

Product code	Description	Size mm	Size inches	Pack qty
EQENTT0810	Infrared Thermometer	119 x 46 x 25	4 11/16 x 1 9/16 x 63/64	1

Psychrometer

The psychrometer is an instrument fitted with two thermometers:

a dry-bulb type and wet-bulb type.

For accurate results, proper circulation of air around the bulbs of the two thermometers must be ensured. To do so, a constant-speed rotary movement (2 or 3 rp/second) is applied for about three minutes. The psychrometric tables provided with the unit enable the determination of the relative humidity for a given temperature and according to the difference in temperature between the two bulbs.



Measurement range: -5°C to +50°C resolution: ± 0.2°C.

Product code	Description	Pack qty
EQPSYC0001	RH Measuring Instrument	1

CPII Indoor Air Quality Monitor

The perfect portable, high-quality instrument for measuring CO₂, relative humidity (RH) and temperature, ideal for temporary exhibitions or spaces without permanent monitoring systems installed.

Battery-powered, with mains adapter available on request for longer-term, in situ use. Includes software which can be used to program, download data and save logged files.



Features

- Dew Point and Wet Bulb calculations
- 18,000 data point memory for CO₂, RH and temperature values
- Maximum, minimum and average value display
- Adjustable CO₂ alarm
- Backlit display
- Mini USB interface

Product code	Description	Pack qty
EQEMCP1101	CP11 Indoor Air Quality Monitor	1
EQEMCP1102	Mains adapter (optional)	1

B-173 Twin Cond

The B-173 Twin Cond is a unique conductivity and salinity meter, which features a waterproof, flat sensor convenient for small sample measurements. The dual-function B-173 meter features a compact design for portability and convenience.



- Can measure samples as small as 100ml
- Functions include one-touch calibration, auto-hold, low-battery indication and auto switch-off
- Temperature alarm alerts you when sample falls outside temperature range

Built-in sensor lets you measure by dipping the tip into the sample or by placing a sample directly on the sample pad using a pipette.

Features

- Auto-ranging and a measurement range from 1µS/cm to 19.9mS/cm
 - One-touch auto-calibration
 - Automatic temperature conversion
- The B-173 Twin Cond conductivity meter ships complete with:
- 2 bottles of standard solution (1.41mS/cm)
 - 1 bottle of de-ionised water
 - 2 CR-2032 lithium batteries
 - 1 pipette
 - 1 storage pouch
 - 1 instruction manual

Product code	Description	Pack qty
EQHCOM173	B-173 Conductivity Meter	1
EQHSS0173	Solution Set	1
EQHCSS0173	Spare B-173 Sensor	1

Microprocessor-Controlled pH Meter

High-performance pH meter using the latest measurement technology. Including a temperature probe, a plastic pH electrode for the measurement of liquids (optional ELC electrode for measuring the surface pH of paper, leather, textiles). Automatic temperature compensation, automatic calibration measurement range from 0 to 10pH temperature probe from 0 to 100°C.



Product code	Description	Pack qty
EQPHM0001	pH Microprocessor	1

B-212 Twin pH Meter

These compact pH meters are able to take highly accurate pH value (acidity-alkalinity) measurements from a single-drop sample. The unique flat sensor allows measurement of powder and solid object samples to be easily taken. The Twin pH meters can be used to measure the pH value of a wide variety of items including tropical fish tank water, river water, drainage treatment solutions, hair, cloth, food, soil and rainwater.

CXD can supply an alternate model for the US on request.

Features

- Micro-volume measurements possible from a single-drop (0ml to few micro) sample solution
- Light, easy-to-clean and waterproof
- A simple, efficient scoop function eliminates the need for pipettes and beakers in taking samples
- A sensor guard protects the delicate electrode

Product code	Description	Pack qty
EQPHM0212	B-212 Twin pH meter	1
EQHSS0212	Spare B-212 sensor	1
EQHSS0004	pH4 solution set	1
EQHSS0007	pH7 solution set	1



Paper and Leather pH Meter

For use on paper and leather, the device utilises a flat-tip probe designed to optimise surface contact with paper and leather. Measurements are automatically compensated for the effects of temperature and the LCD continuously displays the sample's current temperature. All operations can be simply performed with two buttons; messages and symbols are displayed to guide the user through the simple measurement and calibration procedures.



Specifications

- Range: -2.00 to 16.00 pH -5.0 to 105.0°C/23.0 to 221.0°F
- Resolution: 0.01 pH/0.1°C/0.1°F
- Accuracy: ±0.02 Ph (@20°C/68°F) ±0.5°C up to 60°C; ±1°C outside ±1°F up to 140°F; ±2°F outside
- Battery type: 3 x 1.5V AA/IEC LR6
- Battery life: Approx. 1500 hours
- Auto-off: After 8 minutes of non-use
- Environment: 0 to 50°C; RH 100%
- Dimensions: 150 x 80 x 36mm (5.9 x 3.2 x 1.4")
- Weight: 210g (7.4oz)

Product code	Description	Pack qty
EQPHM9171	pH Meter	1
EQHBS7004	Hannah Buffer Sachets pH4.01	1
EQHBS7007	Hannah Buffer Sachets pH7.01	1
EQHBS7010	Hannah Buffer Sachets pH10.01	1
EQHSS7030	Hannah Storage Solution	1
EQHBS0407	Set including 5 x 2 sachets of pH4 and pH7	1
EQHBS0710	Set including 5 x 2 sachets of pH7 and pH10	1

Testo Mini Light Meter – 540

The sensor of the Testo 540 is similar to the spectral sensitivity of your eye which makes it ideal for measuring actual light intensity. The 540 features a convenient hold function and displays max/min values on a large backlit display. It's a handy, strong and easy-to-operate little meter.



Features

- Battery type: 2 Type AAA batteries
- Battery life: 200 hr
- Dimensions: 133 x 46 x 25mm
- Probe type: Lux Meas. Range 0 to 99.999 Lux
- Accuracy: ±3%
- Resolution: 1 Lux (0 to 19.999 Lux), 10 Lux (remaining range)

Product code	Description	Pack qty
EQTLUX0540	Testo 540 Luxmeter	1

Hanna HI 97500 Model

The quality of workplace light is essential in museums, archives and libraries. Insufficient light can affect human performance. The HI 97500 is light, compact and supplied in a watertight case with battery. Very simple to use. Three measuring ranges. High performance light sensor with 1.5m cable.



Specifications

Range: 0.001-1.999 Klux; 0.01-19.9 Klux; 0.1-199.9 Klux
Resolution: 0.001 Klux; 0.01 Klux; 0.1 Klux

Product code	Description	Pack qty
EQHLUX9750	HI-97500 model	1

C-500 Temporary Exhibition and Photography Lux and Colour Temperature Meter

The C-500 assists the photographer in capturing accurate image colour reproduction before the shutter is released. By measuring and correcting mixed lighting, colour temperatures, adjusting for accurate white balance and other colour challenges, the C-500 eliminates countless hours of post-production editing. The four colour sensors (including digital sensor) make it possible to measure colour accurately for film or digital capture.



Product code	Description	Pack qty
EODLLC0500	Lux and Colour Temperature Meter	1

High-Accuracy Balance

These balances are ideal for measurement needing high accuracy. Two models are available: up to 200g with accuracy of ±1mg; up to 2,000g with an accuracy of 10mg. A very competitive price and supplied with batteries.



Applications

Laboratories, conservation studios and library security to weigh items out and in

Product code	Description	Pack qty
EQESBE0200	Maximum 200g, resolution 1	1
EQESBE2000	Maximum 2kg, resolution 10	1

Newsteo Tracker, Data-Logger for Monitoring Transport History

The Newsteo Tracker measures and records up to 6 months of transport history. It includes the recording of temperature, humidity, light and shocks (on 3 axes) as well as free fall height. It also indicates the duration of the shock and its energy.

- Complete and time-stamped history of transport conditions
- Exclusive: measure of the height of free fall
- Detailed information on the shock: acceleration, duration and energy
- Wireless data restitution, without needing to open the package or container
- Guarantee of non-opening of the packages (light sensor).

Continuous monitoring of:

- 3-axis shock
- Shock energy
- Shock duration
- Temperature
- Humidity
- Dew point
- Luminosity
- Free fall height



Application

Transport of fragile goods:

- To encourage careful handling of fragile fine art objects during transport
 - Electronic measurement and logging of handling history during shipment
- Insurance:
- Data log to establish liability in case of damage

Product code	Description	Pack qty
EQTRK0031	Starter Kit. Includes Logger, Cable and Software	1
EQTRKS0031	TRK Data Logger	1



Conservac™ HEPA Vacuum - GS 555 Model

This GS 555 model is compact, lightweight and portable with special vacuum power control for professional dust removal from hard-to-reach places.

The 555 has a 1.2 litre disposable, multi-layer filter bag, advanced six-stage filtration system with HEPA (absolute filter) retaining 97.997% efficiency down to 0.3 micron dust particles, mould, mildew and fungal spores. For increased control over suction the 555 GS model uses a two-stage control system. There are three suction ranges to select by adding or removing plugs in the three inlets which give a wattage equivalent of 400W/500w or 1100w. Within each range the suction can be fine-tuned using an electronic control on the side of the unit.

Size: 315 x 120 x 185mm, Weight: 2.2kg (appliance), Detachable shoulder strap with anti-slip pad.

GS 555 Model and accessories

Product code	Description	Dimensions
EQGSUK0555	UK Model and Mini Nozzle Set (SUCVMN0010)	
EQGSCB0240	UK Model with cable management bracket and Mini Nozzle Set (SUCVMN0010)	
SUCVHC0710	Conservac Hard Carrying Case	400 x 300 x 154mm
SUCVHC0711	Conservac Durable Carrying Case	400 x 300 x 221mm

Product code	Description
SUCVMN0010	Mini Attachment Set

Product code	Description
SUCVAE7050	Medical Air Exit Filter



Product code	Description
SUCVHC0711	Conservac Durable Carrying Case - Large
SUCVHC0710	Conservac Hard Carrying Case - Small



GS 555/777 Accessories

Product code	Description
SUCVBA1708	2-part Blow Assembly (ESD IDEM long hose)



Product code	Description
SUCVCB0709	Standard Carry Bag



Product code	Description
SUCVMT0029	Swivel Action Floor Tool



Product code	Description
SUCVBA0708	2-part Blow Assembly (ESD short hose)



Product code	Description	Dimensions
SUCVMF0726	Combined HEPA Electrostatic Motor Filter	134 x 116mm



Product code	Description
SUCVRN0005	Flexible Rubber Nozzle – 325mm Long x 14 Diameter



Product code	Description
SUCVMT0028	Special Mini Extension Rod Set of 3, total length 1015mm



Product code	Description
SUCVFB0723	Conservac Filter 10-bag Set



Product code	Description
SUCVAA0017	Adjustable Angle Adaptor



Product code	Description
SUCVPD0004	Precision Nozzle Set for Dust Removal



GS 777 Model

A large-capacity Conservac including a low, flat housing and motor mount for greater stability, 3m flexible hose to take attachments, integrated cable storage brackets and 15m cord (UK version) plus quality castors. The GS 777 has a three-stage filtration process, firstly a nine-litre antibacterial microfibre, melt-blown, polypropylene bag then a large round cartridge situated before the motor and finally an air exit filter cassette.



The GS 777 model comes with the option of 3 types of filter package, ISO 8 uses a standard filter, ISO 7 featuring a HEPA filter and ISO 6 which incorporates an ULPA filtration system.

GS 777 Model and accessories

Product code	Description
EQGSUK7778	GS, European Model with ISO 8 Standard Filter Pack
EQGSUK7777	GS, European Model with ISO 7 HEPA Filter Pack
EQGSUK7776	GS, European Model with ISO 6 ULPA Filter Pack
EQGSUK7778	UK Model with ISO 8 Standard Filter Pack
EQGSUK7777	UK Model with ISO 7 HEPA Filter Pack
EQGSUK7776	UK Model with ISO 6 ULPA Filter Pack
SUCVMT07177	ISO 8 Standard Replacement Filter Pack
SUCVMT07178	ISO 7 HEPA Replacement Filter Pack
SUCVMT07179	ISO 6 ULPA Replacement Filter Pack
SUCVMT0750	Conservac Filter 10 Bag Set For 777 Series (Disposable Paper)
SUCVMT0751	Filter Bag Set For EQGSSH7778 (Melt-blown)
SUCVMT0753	Large Filter Cartridge HEPA
SUCVMT0755	Activated Carbon Jacket for Filter Cartridges
SUCVMT0757	Filter Cassette HEPA
SUCVMT0759	Stretch Hose 80cm, extends to 300cm
SUCVMT0760	Super Stretch Hose 160cm, extends to 800cm
SUCVMT0752	Large Motor Filter Cartridge. Standard (ISO 8) Black



GS 777 Accessories

Product code	Description
SUCVMB0007	Pair of Mini Brushes, goat hair - very soft
SUCVMB0008	Pair of Mini Brushes, horse hair - medium hard
SUCVMB0009	Pair of Mini Brushes, hog hair - hard



Product code	Description
SUCVDB0012	D-shaped Brush, horse hair - medium hard
SUCVDB0013	D-shaped Brush, goat hair - very soft



Product code	Description
SUCVMF0727	Micro motor filters, HEPA activated carbon filter media B/W



Product code	Description
SUCVMT0752	Large Filter cartridge



Product code	Description
SUCVMT0755	Activated Carbon Jacket for Filter Cartridges



Product code	Description
SUCVMT0759	Stretch Hose 80cm, extends to 300cm



Product code	Description
SUCVMT0753	Large Filter Cartridge HEPA



Product code	Description
SUCVMT0760	Super Stretch Hose 160cm, extends to 800cm



Product code	Description
SUCVMT0751	Conservac Filter 10 Bag Set for EQGSSH7778 (Melt-blown)



Product code	Description
SUCVMT0757	Exit Filter Cassette HEPA



Nilfisk GD1005

A vacuum cleaner especially designed for removing dust from objects and documents in archives, museums or libraries. Characteristics: cylinder type vacuum cleaner with a round container mounted on wheels.

Quiet operation (55/60dB). High amplitude (from 30 to 1200w) suction power control offering great versatility. Fitted with a HEPA filter preventing particles of around 0.3 microns in size from being spread into the atmosphere. 10m electrical cable.



Applications

The GD1005 is a reliable, high-performance vacuum cleaner. Its variable power control system allows it to remove dust from fragile documents or from a full set of shelves. Shipped with: 2 rigid tubes, 1 x 2m flexible accordion tube, 1 adjustable round brush, 1 kit of accessories for micro-vacuuming. As an option there is a range of brushes suitable for all types of vacuum-cleaning.

Product code	Description	Pack qty
EQNILF0501	Vacuum with regulator	1
EQNILF0502	Vacuum without regulator	1
EQNILF0503	HEPA Filter for GD1005	1
EQNILF0504	Bag for GD1005	1

Nilfisk GWD320

Nilfisk Viking GWD320 wet and dry vacuum cleaner. Compact, handy and manageable, it has the same variable suction unit as the GD1005, which is well-known for its excellent performance and reliability. The unit is independent of the device so it can be fixed onto a table.

This model has been designed to suck up liquids making it an ideal companion for low-pressure suction tables and essential equipment for a disaster-preparation kit.



Product code	Description	Pack qty
EQNILF3201	Vacuum with regulator	1
EQNILF3202	Vacuum without regulator	1
EQNILF3203	Bag for GWD320	1

Nilfisk Brushes

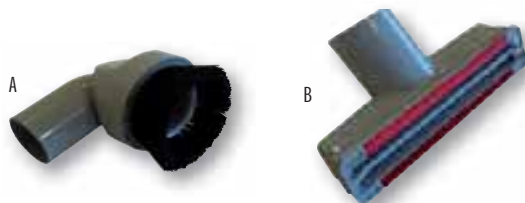

Product code	Description	Pack qty
EQNILB0001	A 32mm diameter	1
EQNILB0002	B Swivel action floor tools	1

Nilfisk GD5VH Back Pack Cleaner

Cleaning made easy

- Low sound level for operator comfort and cleaning in noise-sensitive areas
- Good filtration with HEPA filter option
- Suitable for left or right-handed use
- Containers in different sizes to fit the application
- 15 metre detachable cable with safety release saves time moving to other power sockets
- Lightweight vacuum cleaner and a harness that is ergonomically designed to reduce fatigue

There are many things that should be present in a good backpack vacuum cleaner. It should be light in weight, with even weight distribution, and the noise level must be as low as possible.

Accessories

1 filter bag, 1 filter HEPA, 1 flexible hose, 2 rigid pipes, 1 floor nozzle, 1 battery and 1 recharger.

Specifications

Description	Unit	CD 5 Battery	Size mm	Size inches
Nilfisk Back Pack Cleaner			380 x 330 x 700	14 ⁹ / ₆₄ x 12 ⁶ / ₆₄ x 27 ¹ / ₁₆
Rated power	W	1300		
Suction power end of tube	W	240		
Airflow	l/sec	40		
Vacuum at nozzle	kPa	20		
Sound pressure levels 5415	dB(A)	59		
Bag capacity	Litres	5		
Main filter area	cm ²	1400		
Length x width x height	cm	38 x 33 x 70		
Weight	kg	4.2		

Product code	Description	Pack qty
EQNIGD0001	Vacuum with regulator	1
EQNIGD0002	Vacuum without regulator	1
EQNIGD0003	Bag for GD5BH	1
EQNIGD0004	HEPA Filter for CD5BH	1
EQNIGD0005	Bag holder filter	1



GD 5B Battery freedom to clean anywhere

Remarkably quiet operation that makes daytime cleaning in offices and hospitals viable.

Ergonomic backpack harness is of premium design to ensure comfort and to minimise stress.

Innovative technology ensuring top performance with fully recyclable components for reduced ecological impact.

The Nilfisk GD 5B Battery is a backpack vacuum that requires no electrical connections, thus offering greater freedom to clean just about anywhere. With a running time up to 30 minutes per battery and with extra battery packs available, the machine can be used continuously. The charging time for one battery can be completed in just 45 minutes.

Accessories

1 filter bag, 1 flexible tube, 2 rigid pipes, 1 floor nozzle, 1 battery and 1 battery charger.

Option

Additional Battery or HEPA filter.

Specifications

Description	Unit	GD 5B Battery
Rated power	W	400
Suction power end of tube	W	166
Airflow	l/sec	30
Vacuum at nozzle	kPa	20
Sound pressure levels 5415	dB(A)	57
Bag capacity	Litres	5
Main filter area	cm ²	1400
Length x width x height	cm	38 x 33 x 70
Weight	kg	7.7

Product code	Description
EONIGD1001	GD5 Complete with Battery and Charger
EONIGD1002	GD5 Additional Battery
EONIGD0006	Exhaust Filter HEPA



Air Purifiers

While museum, gallery and archival employees are urged and sometimes required to wear specialised respirators when dealing with hazardous airborne contaminants, the use of a full-face or airline respirator is of no help in eliminating the build-up of fumes and pollutants in the ambient air. AllerAir[®] Source Capture Air Purification Systems are equipped with robust filters to arrest both gaseous and particle pollutants before they can contaminate the ambient air in the room.

AllerAir[®] units are designed for tackling gaseous pollutants, odours and particle contaminants in open galleries, artefact storage facilities and restoration laboratories. Systems can be installed and aligned with the building HVAC system, or be employed to create positive air pressure in a given area. Whether ducted or freestanding, AllerAir[®] air cleaners provide a meticulous air-filtration system to combat corrosive chemicals, outdoor air pollutants, and mould and particle contaminants.

Regulating the air quality in a museum, gallery, library or archive is imperative to the conservation of artefacts. Studies show that indoor air pollutants can be just as damaging as exposure to sunlight. Stabilisation is an ongoing process that requires careful attention to more than just temperature and humidity calibration. In order to trap both gaseous and particle pollutants that threaten to deteriorate valuable museum materials, AllerAir[®] cleaners contain activated carbon filters along with medical-grade HEPA filters.

Clean Breeze III – Fume Source Capture

The Clean Breeze III is designed to capture harmful airborne contaminants at the source with activated carbon and more inches of bed-depth for maximum chemical odour absorption, to keep the harmful particles away from other artefacts and workers.



Specifications

- Filtration 10kg of special carbon mix, 7.6cm bed-depth, Micro HEPA wrap-rated at 99% efficient at 0.1 microns dust filter
- Manoeuvrable on four wheels
- Easy access to dust filter
- Main filter access on bottom with screws
- Adjustable swing arm with three elbow
- Dimensions: 60cm x 37.5cm

Product code	Description	Pack qty
EQCBVC0003	Clean Breeze III	1
EQAPFM0128	Pre-Filters 8 Pack	1
EQCBMR6002	DX Micro-HEPA	1
EQCBCW6335	DX Exec Carbon	1

5000 DX Vocarb – Room Air Cleaner

Not all conservation involves restoration with harmful chemicals and toxins and yet, proper air filtration is still a necessity, especially in the rooms where precious artefacts are stored.



Specifications

- 12.25kg carbon filter, 8.89cm deep carbon bed, micro-HEPA wrap-rated at 99.97% efficient at 0.1 microns, pre-filter
- Fan Power 244m³/h
- Dimensions: 52.07cm x 38.1cm
- 10.16cm x 15.24cm wheels

Product code	Description	Pack qty
EQAPDV5000	5000 DX Vocarb	1
EQAPFM0009	5000 Pre-Filters 8 Pack	1
EQDXCW5235	5000 DX Vocarb Carbon	1
EQDXMR5002	5000 DX Micro-HEPA Filter	1

5000 Exec UV – Archival Protection Systems

Pollutants and particles lingering in the air can land on exposed historical documents and artefacts and cause corrosion, mould and degradation. However, a powerful air filtration unit like the 5000 Exec UV will ensure archival rooms will have fresh, particle-free air to better protect your precious items.

A UV lamp offers the added benefit of sterilising any bacteria, viruses or mould mycotoxins that may be present in the air. The UV actually destroys the reproductive DNA of these organisms. This kind of sterilisation is highly effective and has been used in hospitals, laboratories and medical facilities since the 1930s. The UV lamps AllerAir[®] employs do not produce ozone.



Specifications

- 8.16kg carbon filter, 6.35cm depth, medical-grade HEPA, pre-filter
- 10w UV bulb
- Fan Power 244m³/h
- Dimensions: 52.07cm x 38.1cm

Product code	Description	Pack qty
EQAPEU5000	5000 Exel UV	1
EQEXUW5225	5000 Pre-Filters 8 Pack	1
EQEXUH5411	5000 HEPA	1
EQAPFM0009	5000 EXEC Carbon	1



Mobile Dust Cleaner

The safe removal of dust is often the first step in a series of treatments when receiving a new or moving an existing collection of books, documents or objects for conservation or exhibition.

Storage in poor conditions could result in objects harbouring superficial dust, bacteria, insects or mould spores which can be dangerous to handlers. These pathogens can be removed with high-quality, dry-dust cleaning equipment so long as they have not impregnated the material.

The System consists of a triple-filter suction device connected to a 'swing arm' which connects, via a flexible hose, to one of six possible brushes to simultaneously brush off dust and pick up loose dust or debris. Also connected to the suction device is a hinged suction table on which objects are placed to be cleaned, ensuring dust and loose particles are removed from the working environment.

The first filter is a polyethylene cyclone for filtering the bigger pieces, which are retained by a conical, non-return trap. Water particles can be separated by the cyclone, leaving the pre-filter dry. The long-life pre-filter built into the cyclone has a 12.5m² surface area providing 99.9% efficiency. This can be easily cleaned with a short burst of compressed air. The micro-fine filter contained in a polyethylene cylindrical housing, filters at 99.997% efficiency.

The swing arm has a 1.5m range of movement and is height-adjustable to between 1.9m and 2.7m. The suction strength is fully adjustable to suit the needs of the objects being cleaned.

The suction table is built to allow a high vacuum (15mBar) and a perforated working surface made of non-corrosive stainless steel with 1mm round perforations in a triangle setting permitting a maximum mesh of 26% per m². The suction table is connected to the triple-filtered suction device via a flexible polyethylene 50mm diameter pipe.

Product code	Description	Pack qty
EQCXDU2213	Mobile Dust Cleaner	1

Bassaire Mobile Clean Air Conservation Work Station

The deluxe Bassaire operator safety cleaning station has an advantage over alternative systems that only pull the air downwards, as it features unique suction walls around the back and sides of the machine to increase the surface area for air extraction. The workstation is 1050mm wide x 656mm deep x 1015mm high with a working area of 780mm x 560mm x 493mm.

Smaller airborne particles that have been removed from the work area are trapped in two easy-to-access filters, that can also be cleaned and reused up to four times. Built from stainless steel it features a sturdy pull handle and robust lockable swivel castors for ease of mobility.

Pre-filter (95% efficient 5 microns)

HEPA filter (99.997% efficient at 0.3 microns)



Product code	Description	Pack qty
EQBASS0001	Bassaire Document Work Station	1
EQBASS0003	Bassaire Replacement Pre-filters	1
EQBASS0004	Bassaire Replacement HEPA Filter	1
EQBASS0002	Bassaire Pre-Filter 990 x 560mm	1

 *Linked Products: Gloves p215; Mould Mask p214; Brushes p216-220.*

Spirabilia™

The Spirabilia™ conservation workstation allows cleaning to take place within a sealed chamber, accessible by a pair of protective sealed and sleeved gloves with which the operator can work in safety. Extraction from within the unit uses an industrial quality HEPA filtered vacuum cleaner with a large capacity dust container. Spirabilia™ is also suitable for cleaning museum objects in ethnographic, geological and natural history collections.



Specifications

- External Dimensions (W x D x H): 1055 x 725 x 1525mm
- Hands insertion height: 1040mm
- Work plain height: 1000mm
- Work plain measures (W x D): 940 x 640mm

Product code	Description	Size mm	Size inches	Pack qty
EQBCSP0001	Spirabilia™, Book Cleaning Workstation	1055 x 725 x 1525	41 ¹ / ₂ x 28 ⁵ / ₁₆ x 60 ³ / ₁₆	1
	Hands insertion height	1040	40 ⁷ / ₁₆	
	Work plain height	1000	39 ³ / ₁₆	
	Work plain measures	940 x 640	37 ¹ / ₁₆ x 25 13/16	

 *Linked Products: Brushes p216-220.*

Depulvera

Delivering fast yet gentle book-cleaning, this power-driven, automatic book-cleaner has been designed to give consistent high-quality cleaning with the last book of the day being cleaned as effectively as the first. The Depulvera is compact and simple to use and can be operated by conservators or library technicians in all but the narrowest book stack aisles. The purpose of this is to allow cleaning to be undertaken close to where the book is stored thus saving the need for additional moving of the collection.

The Depulvera is mobile, self-contained and features a separate HEPA vacuum unit to provide a safe environment for the operator protecting against dangerous mould spores and pathogens when cleaning ancient and fragile rare books and manuscripts.

For those whose budgets do not allow the purchase of a unit outright, short-term hire of the Depulvera is now available.



Specifications

- Machine Dimensions (W x L x H): 750 x 1150 x 1200mm
- Maximum Dimensions of book: 140 x 400 x 300mm
- Speed of work: up to 12 books/minute

Product code	Description	Pack qty
EQBCAD1144	Depulvera Book Cleaner and Vacuum	1
RNBCAD1144	Depulvera Book Cleaner and Vacuum – Rental	1

 *Linked Products: Gloves p215; Mould Mask p214; Brushes p216-220.*

L'Aura

Designed for the safe, efficient, semi-automated cleaning of large books, documents, folders and files. With two models, Standard and Royal, L'Aura is capable of cleaning books larger than the Depulvera despite being a smaller unit, meaning it can still be used along most narrow aisles. This is made possible by passing the books through the machine twice to clean all sides. The natural bristles used will neither hold a static charge nor attract dust so the books are always cleaned with a clean brush.



Specifications

Specifications	Standard size mm	Standard size inches	Royal size mm	Royal size inches
Machine Dimensions (W x L x H)	590 x 770 x 1120	23 ³ / ₄ x 30 ³ / ₈ x 44 ¹ / ₂	590 x 770 x 1120	23 ³ / ₈ x 30 ³ / ₈ x 44 ¹ / ₂
Maximum dimensions of book	400 x 400 x 210	15 ¹ / ₄ x 15 ¹ / ₄ x 8 ¹ / ₄	600 x 600 x 300	23 ³ / ₈ x 23 ³ / ₈ x 11 ¹ / ₈
Speed of operation	Up to 6 books/minute			
Electrical supply	220v-230v			

Product code	Description	Pack qty
EQBCRL0001	L'Aura Book Cleaner Royal	1
EQBCSL0001	L'Aura Book Cleaner Standard	1

 *Linked Products: Gloves p215; Mould Mask p214.*

Kenair Air Duster

The Kenair 360ml Air Duster is popular with photographers and conservators requiring localised dust removal without the use of cleaning cloths or brushes. Supplied with a standard spray nozzle but can also be fitted with the optional Jet PRO variable power-flow trigger nozzle.



Product code	Description	Pack qty
EQAIRP0002	Optional Jet PRO 360	1
EQAIRP0001	Kenair 360ml with standard Jet 360	1
EQAIRP0003	Kenair 360ml only	1

Pulvisina

'A small book-cleaning machine for all budgets.'

This bench-top, book-cleaning machine is great for libraries and archives that may not have the volume or budget to warrant a Depulvera or L'Aura but still require consistent high-quality results. Pulvisina is capable of cleaning three sides of up to six books per minute by one person.

Product code	Description	Pack qty
EOBCPV0001	Pulvisina Book Cleaning Machine	1
EOBCPV0002	Ergocar	1

Note. The vacuum and adjustable trolley sold separately.



Ergocar and vacuum sold separately

 *Linked Products: Gloves p215; Mould Mask p214; Conservac p200-201 and Nilfisk vacuum cleaners p202-203.*



Ultra Microfibre Cloth – White

A white microfibre finishing cloth made from synthetic 80% polyester and 20% polyamide material containing no chemical additives. Used wet, the microfibre cloth is effective for cleaning all types of surfaces including glass, plastic, chrome, wood. Used dry, the positive charge of microfibre cloth picks up dust. Machine washable at 95°.



Product code	Description	Pack qty
SUWMFC7523	Microfibre Cloth – White	1

Linked Products: ConserVac Equipment p200-201; Gloves p215.

Microfibre Cloth – Yellow

A yellow finishing cloth made from a microfibre material, which efficiently removes oily film and residue – without the use of a cleaning agent. Made from a blend of 70% polyester and 30% polyamide, which enables the microfibre material of the cloth to disperse surface dirt, grease, grime and dust and then pick it up, cutting through dirt and absorbing it inside the fibres. These fibres clean, polish and quickly absorb up to seven times their weight in moisture and can be used on all hard surfaces. Machine washable and can be rewashed up to 300 times. This cloth can be used either wet or dry and is long-lasting and durable.



Product code	Description	Pack qty
SUYMFC0001	Yellow Microfibre Cloth	1

Linked Products: ConserVac Equipment p200-201; Gloves p215.

Cleaning Swab Sticks

- A. Absorbent cotton swab with wooden handle – length: 150mm. Perfect for cleaning delicate surfaces or application of various cleaning solutions.
- B. Cotton swab fitted with polyurethane foam cap; wooden handle. Length: 150mm. Application same as 'A' but with greater absorbent capacity.

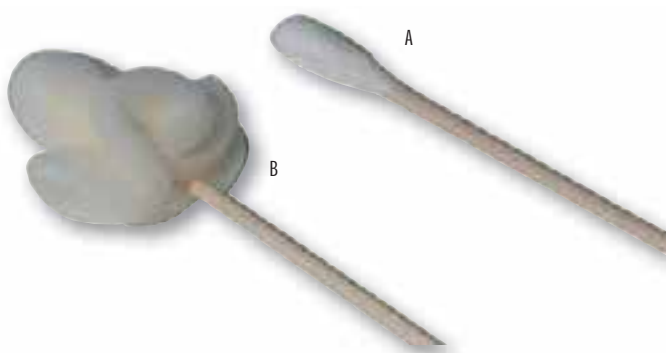

Product code	Description	Size mm	Size inches	Pack qty
EQSWAB0001	A Standard	150	5 ⁹ / ₃₂	200
EQSWAB0002	B Polyurethane Cap	150	5 ⁹ / ₃₂	50

Speck-Grabber

A wooden stick with an adhesive synthetic tip to enable dust and other undesirable particles to be collected and removed from a picture, for instance, without having to dismantle it completely. The adhesive tip leaves no marks. Speck-Grabber comes with two sticks in a transparent carrying case for optimum protection and storage.



Speck-Grabber can be washed with soap and water without damaging its properties. Leave to dry before further use.

Product code	Description	Pack qty
EQSPEK0002	Speck-Grabber stick	2

Sontara® Wipes

Sontara® non-woven, hydro-entangled, spun-lace fibre is a combination of polyester, rayon, acrylic, nylon and wood cellulose. Crêped texture with no chemical binder or other additives. A large liquid absorption capacity, great resistance to all commonly used solvents, acids and bases. Flexible and strong for cleaning all surfaces. Supplied 'Z' folded in boxes of 200. Colour: White.



Sontara® is a registered trademark of Dupont.

Product code	Size mm	Pack qty
EQWIPE3432	340 x 320	200

Anti-Static Cloth

An extremely soft, non-abrasive synthetic microfibre cloth which is highly anti-static. Made from two different fibres: the conductor part of the fabric conducts electricity from charged sources while the ultra-soft microfibres remove dust and all kinds of encrustations. This cloth is not impregnated in any way, therefore its conductive effect lasts its entire serviceable life. Furthermore, it can be washed to temperatures of up to 40°C and, once dry, reused.



Application

Delicate cleaning of photographic negatives, slides, glass, plastic, acrylic materials

Product code	Size cm	Colour	Pack qty
EQANTI0001	25 x 45	Orange	1

Anti-Static Cleaning Kit - only for glass

This kit contains an anti-static microfibre cloth and an Isopropanol cleansing liquid. Applications include delicate glass cleaning of screens, lenses, scanners, magnifying glasses, etc.



Product code	Description	Pack qty
EQGLAS6001	Contains Microfibre Cloth and 6ml Solution	1

Polish and Dressings

Wax 213 – Colourless

Made to a formula of the French National Library. Colourless Wax 213 with a neatsfoot oil base which nourishes the leather while hydrating it. Essential elements are provided which restore some flexibility to dry, cracked leather. It also contains fungicides and insecticides and is pH neutral.



Product code	Description	Pack qty
EQLWAX2131	Wax 213 - 50ml pot	1
EQLWAX2132	Wax 213 - 200ml pot	1

Bracknell Soap

A powerful concentrate with a very attractive matt finish. Formula obtained by mixing various soaps to ensure smoother application. Easy and quick to use.



Product code	Description	Size	Pack qty
EQLWAX0001	Bracknell Soap	180g	1

Archival Aids - British Museum Leather Dressing with Beeswax

A liquid dressing for leather that is dry, hard, brittle or otherwise out of condition. It should be applied sparingly to all available surfaces. In most cases the dressing should be absorbed within one to five days, according to the condition of the material. A proprietary product manufactured in our own factory to ensure quality and consistency. Eminently satisfactory for the treatment of leather bookbindings. First feed the leather with this preparation followed by a thin coat of Renaissance Wax. Avoid breathing vapour.

Product code	Description	Pack qty
SULDBM7018	Archival Aids - British Museum Leather Dressing with Beeswax	1 litre

Archival Aids - British Museum Leather Dressing without Beeswax

Research has shown that better protection can be given if the final surface coat is a micro-crystalline preparation. First feed the leather with this preparation followed by a thin coat of Renaissance Wax. Also works where the dressing must be applied to the flesh side or where the surface of the leather does not require polishing. A proprietary product manufactured in our own factory to ensure quality and consistency. Avoid breathing vapour.

Product code	Description	Pack qty
SULDSP7251	Archival Aids - British Museum Leather Dressing without Beeswax	1 litre

Archival Aids - Lanolin, Anhydrous

Anhydrous Lanolin is an excellent lubricant for leather.

Product code	Description	Pack qty
SUAALT0400	Anhydrous Lanolin	1

Pre-Lim Surface Cleaner

A gently abrasive paste for non-scratch cleaning of metals and many sensitive fine-art surfaces.



PreLim is widely used in the professional restoration of arms and armour, sculpture, brass and copper exhibition cookware, ceramics and automobile paintwork.

Formulation is based on blended Neuburg silica chalks in a water/white spirit emulsion. In normal use the product is not a health hazard.

Pre-Lim's cleaning/burnishing action is achieved with extremely fine control using a soft rag and light pressure. After a few minutes of air-drying, the residual chalky deposit is easily rubbed away with a clean rag, leaving surfaces dry and silk-smooth.

To ensure that cleaned surfaces, especially metals, remain clean and bright, protect them with glass-clear Renaissance micro-crystalline wax polish for a long-lasting and visually-enhancing finish.

When stored in its airtight container at room temperature or colder, Pre-Lim has an excellent shelf life.

As is customary in professional restoration, a discreet test is advised to ensure that Pre-Lim is suitable for specific projects.

Product code	Description	Pack qty
SUPLSCO065	Pre-Lim Surface Cleaner 65ml	1
SUPLSCO200	Pre-Lim Surface Cleaner 200ml	1

Renaissance Wax Polish

A blend of highly refined micro-crystalline fossil-origin waxes made to a formula used by the British Museum and restoration specialists internationally. Used to revive and protect valuable furniture, leather, paintings, metals, marble, onyx, ivory etc. It gives a hard not sticky protective coating that does not attract dirt. Freshens colours and imparts a soft sheen. Renaissance Wax will also protect polished surfaces from normal domestic spillage including wine and spirits.



Product code	Description	Capacity	Pack qty
SURWAX7078	Tin	200ml	1
SURWAX7080	Tin	65ml	1
SURWAX7125	Can	3 litre	1

Renaissance Metal De-Corroder

Safe, Non-toxic System for Rust Removal with Full Control.

Amine complex of hydro-oxycarboxylic acid in aqueous solution. pH: approx 4.0.



Product code	Description	Capacity	Pack qty
SURMDC0100	Renaissance Metal De-Corroder	100ml	1
SURMDC1000	Renaissance Metal De-Corroder	1 litre	1

Conservation Cleaning

Care Kits

Four of our popular Renaissance products in compact sizes, ideal for our customers' own specialised after-sale care kits. We can supply any or all four products to suit individual needs.



This kit includes: 1 x Renaissance wax 65ml, 1 x Pre-Lim 65ml, 1 x Vulpex Liquid Soap 100ml and 1 x Renaissance Metal De-Corroder 100ml

Product code	Description	Pack qty
SUCAKT0004	Care Kits	1

Vulpex Liquid Soap

(Potassium Methyl Cyclohexyl Oleate)

Non-acid, non-foaming, non-corrosive, non-hazardous, germicidal.

Vulpex liquid soap is a safe cleaner for practically everything from paper to stone.



Since its introduction in 1970, its extraordinary versatility has made Vulpex a popular and indispensable medium in all branches of professional restoration and conservation of fine art objects and historic property.

It has been used with eminent success in the safe and controllable cleaning of materials ranging from feathers, costumery, leather, carpets and furniture to oil paintings, armour, precious metals, shell, marble and stone.

Vulpex attacks and emulsifies dirt, fats, fatty oils, mineral oils, waxes and hydrocarbons with great speed and efficiency. The dirty emulsions are remarkably stable, thus easily disposable. Micro-fine cracks harbouring dirt are subject to a deep-cleansing action rarely achieved with normal commercial cleaners.

Compared with harsh, acid-based cleaners, alkaline Vulpex is not harmful to health or property. A final rinse or wipe with clean water neutralises the surface, leaving behind nothing to create future conservation problems.

When the job demands a non-aqueous cleaning system (for example, when removing grime from leather), Vulpex uniquely can be blended with mineral spirit (paint thinner/white spirit) instead of water.

Vulpex is supplied as a dense concentrate and must be diluted before use. For normal aqueous cleaning, one-part Vulpex to six or seven-parts cold tap water (by volume) is sufficient. More water can be added if the soiling is light. As a spirit soap, one-part Vulpex in ten to twenty-parts solvent will be found effective.

Since Vulpex is a highly effective de-greasant, hands should be protected against the loss of natural oils by wearing gloves or the subsequent use of a lanolin hand-cream. Eyes should be protected from splashes.

Product code	Description	Size	Pack qty
SUVULP0100	Vulpex Spirit Soap	100ml	1
SUVULP1000	Vulpex Spirit Soap	1 litre	1

Vulcanised Smoke Sponge

Unique dry sponges made of vulcanised natural rubber, completely safe and non-toxic for cleaning smoke-covered walls and artefacts, soot damage and general dust.



Product code	Description	Size mm	Pack qty
SUVSSL0003	Large Vulcanised Smoke Sponge	152 x 76 x 44	1
SUVSS0001	Small Vulcanised Smoke Sponge	152 x 76 x 19	1

Draft Clean – Granulated Eraser

Now with a new pH neutral mustard colour specification, fine granules of powdered rubber in pad or tub form for cleaning artwork, pencil drawings, manuscripts, charts and three-dimensional art objects.



Product code	Description	Colour	Size mm	Pack qty
SUDCCP0090	Pad Std	Mustard	90	1
SUDCCP0188	Pad Large	Mustard	188	1
SUDCPX0003	Granules – 1kg drum	Mustard	902	1

Wishab Sponge Erasers

Wishab dry sponge erasers are available in three different grades according to the type of surface to be cleaned. Made from a special neutral pH vulcanised latex material.



Application

Dry cleaning of soiled surfaces: ceiling walls, pictures, wall paintings, frescoes, wallpaper, textiles etc.

Product code	Description	Pack qty
SUERAS0003	Hard	1
SUERAS0004	Extra hard	1
SUERAS0005	Soft	1
SUERAS0006	White for cleaning paper	1

Plastigom Granulated Plastic Eraser

A vinyl-based, sulphur-free, medium-grain, powdered plastic eraser which works effectively while causing the least damage when cleaning documents.



Product code	Description	Size	Pack qty
SUERAS0007	Plastic Eraser Powder	500g	1
SUERAS0008	Plastic Eraser Powder	2kg	1

Rowney Kneadable Rubber

A malleable rubber for pencil and charcoal drawings designed to retain particles. Packed in individual boxes.



Product code	Description	Size mm	Size inches	Pack qty
SUERAS0009	Kneadable rubber	35 x 25	1 3/8 x 63/64	Pack of 6
SUERAS0010	Kneadable rubber	35 x 25	1 3/8 x 63/64	Box of 36

Groom/Stick

A Unique Non-abrasive Paper Cleaner

Groom/Stick is a novel form of natural rubber with specific properties combining to create a surface dry-cleaner of high efficiency.



The rubber's natural structure has been modified to make it permanently soft, kneadable and strongly tacky. Moisture, solvents and chemical additives have been excluded.

As a non-abrasive, non-staining cleaner of paper and other library materials, Groom/Stick gently but positively picks up a wide range of foreign matter. Graphite, carbon, charcoal, chalk, crayon, dry powder colours, mould spores, dust, dirt and grease are cleanly lifted off the surface and held in a 'molecular trap' from which there is no escape!

The process is fast and smear-free. It is demonstrated by lightly rolling a Groom/Stick 'cigar' across a freshly-printed newspaper. Excess print ink is removed instantly – without blurring the print or soiling adjacent clean areas.

Ordinary solid or granular rubber/resin erasers abrade, smudge, crumble or produce clinging debris. Groom/Stick sacrifices nothing of itself, leaves no dirty fragments to brush away (or mould spores to regenerate in concealed areas) and is always ready and clean to use.

Product code	Description	Capacity	Pack qty
SUGRST0100	Groom/Stick Paper Cleaner	100ml	1

Art Gum Eraser

Special non-abrasive eraser sometimes called 'soap eraser' which crumbles to produce an in-depth cleaning powder. Removes marks on paper documents, mount-board, fabric etc.



Product code	Description	Pack qty
SUERAS0011	Art Gum	6
SUERAS0012	Art Gum	12

Crêpe Gum

In its natural state, rubber comes in the form of a milky liquid known as latex. This liquid is then filtered and undergoes various processes until we obtain this sheet of crêpe commonly used in the shoemaking industry. It also has an application in the graphical field where it is used as an effective gum for removing residues of adhesives.

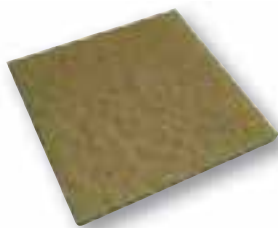

Sachet of six

Product code	Description	Size mm	Size inches	Pack qty
SUERAS0013	Crêpe Gum	50 x 50 x 5	1 ²⁵ / ₃₂ x 1 ³¹ / ₃₂ x ¹³ / ₆₄	6

Pentel Click Eraser

Vinyl plastic eraser in pen-type body. The rubber is advanced by a click mechanism.



Uses ZER 2 refills.

Product code	Description	Pack qty
SUERAS0016	Pentel Mechanical Click Eraser	1
SUERAS0017	Pentel Mechanical Click Eraser	12
SUERAS0018	Replacement Erasers	12
SUERAS0019	Replacement Erasers	24

Maped™ Technic 600 Vinyl Eraser

A general purpose vinyl plastic eraser for paper and tracing paper.



Product code	Description	Size mm	Size inches	Pack qty
SUERAS0023	Vinyl Eraser	60 x 20 x 12	2 ³ / ₆₄ x 0 ² / ₃₂ x 0 ¹³ / ₃₂	Box of 20

Maped™ Architect Eraser

A general purpose vinyl plastic eraser for paper and tracing paper.



Product code	Description	Pack qty
SUERAS0014	Vinyl Eraser	5
SUERAS0015	Vinyl Eraser	16

STAEDTLER Mars Plastic Eraser

A high-quality vinyl plastic eraser used by paper conservators for many years which the manufacturer now states is phthalate and latex-free with practically residue-free erasing and minimal crumbling.



Product code	Description	Size mm	Size inches	Pack qty
SUERAS0001	Mars Plastic Eraser	60 x 20 x 12	2 ³ / ₆₄ x 0 ² / ₃₂ x 0 ¹³ / ₃₂	6
SUERAS0002	Mars Plastic Eraser	60 x 20 x 12	2 ³ / ₆₄ x 0 ² / ₃₂ x 0 ¹³ / ₃₂	20

Chemicals, Solvents and Cleaning Fluids:

Archival Aids - Chemikit Paper Testing Kit

A complete kit of materials for paper testing. Contents include sufficient chemicals in easy-to-use dropping bottles to determine presence of lignin, acid, starch, alum and alum rosin size in paper. A set of instructions are supplied. A bespoke carry case is available for safe storage and transportation of the kit.

Contents 25ml each:

- Phloroglucinol
- Iodine
- Chlorophenol
- Aluminon
- Sugar water
- Sulphuric acid

Applications

The following spot tests can be carried out simply without the need for any specialised equipment. Always remember that the tests will stain the paper and so should be carried out on a scrap piece or in the margin.

Use

1. Groundwood (lignin)

Apply one spot of Phloroglucinol. If present, will turn a deep purple.

2. Starch

Apply one spot of Iodine. Turns blue in the presence of starch.

3. Acidity

Apply one drop of Chlorophenol, which will turn yellow if acid, purple if alkaline.

4. Alum test

Apply one spot of sugar water. If present, will turn a very bright deep pink.

5. Alum Rosin size

Apply one spot of sugar water. Wipe off excess liquid and add one spot of sulphuric acid. If present turns pink. Caution: This test should be carried out very carefully as sulphuric acid can cause serious burns to the skin and will damage clothes etc. If in contact with skin or eyes, drench with water thoroughly. Apply magnesia paste if burn is serious. If swallowed, wash mouth out thoroughly with water, drink plenty of water followed by milk of magnesia. Seek medical attention.

Product code	Description	Pack qty
EOCHEM001	Chemkit paper testing kit	1
SUCHKT002	Carry case for Chemkit	1

Archival Aids - Epoxy Disintegrator

A volatile, non-flammable solvent formulation of our own manufacture. It is of low toxicity, designed for the dismantling of epoxy resin joints. Prolonged immersion causes the epoxy resin to soften and swell, allowing the pieces to be taken apart.

Care must be taken with decorated ceramics, as it will remove gilding and may attack other decorations.

Product code	Description	Pack qty
SUEPSL1200	Epoxy Disintegrator 1 litre	1

Archival Aids - Benzotriazole, Pure

A vapour phase inhibitor for copper and its alloys. A 3% solution of benzotriazole in industrial methylated spirit or water is used for the stabilisation of copper and bronze, suffering from bronze disease.

Further information available.

Product code	Description	Pack
SUAVLR0400	Pure Benzotriazole 100g	1



De-acidification Solutions and Equipment

Archival Aids De-acidification (AADA) Solution

AADA solutions are non-aqueous treatments for paper, AADA solutions are non-aqueous treatments for preserving all types of paper and card. They are colourless, safe solutions which can be applied by dipping, spraying or brushing and are effective in neutralising existing acidity as they deposit an alkaline reserve throughout the paper which increases the life of documents by several times more than normal. They may also assist in cleaning and will provide a resistance against oxidative attack. They are simple to use, rapid and cost-effective and avoid the problems associated with aqueous treatment methods especially as books may be treated whilst bound without any danger of swelling or breakage of the binding. Unlike previous formulations these AADA solutions do not contain any CFC components, but otherwise the active ingredients remain the same and so in effect they have been in use for more than two decades by leading libraries and institutions throughout Europe, including the British Library and the Bibliothèque Nationale. Papers and documents treated by these solutions have been thoroughly tested by a number of independent institutions.

Product code	Description	Capacity ltr	Pack qty
SUDACS0005	Archival Aids De-acidification Solution	5	1
SUDACS0019	Archival Aids De-acidification Solution	19	1
SUDACS0025	Archival Aids De-acidification Solution	25	1

Archival Aids Cleaning Solution

Recommended for rinsing and cleaning all equipment used in the AADA process.

Product is flammable, take all appropriate precautions.

Please contact CXD for further information

Product code	Description	Capacity	Pack qty
SUPTDA0011	Archival Aids Cleaning Solution	1 litre	1
SUPTDA0015	Archival Aids Cleaning Solution	5 litre	1
SUPTDA0019	Archival Aids Cleaning Solution	19 litre	1
SUPTDA0125	Archival Aids Cleaning Solution	25 litre	1
SUPTDA1016	Archival Aids Cleaning Solution	600ml	12
SUPTDA0016	Archival Aids Cleaning Solution hand spray unit	600ml	1

Delivery price on application

Fume Extraction Cabinet with Air Purifier

This equipment is being used in many restoration workshops around Europe. It conforms to standard EN-1822 CE covering toxic emissions.

The cabinet is fitted with a lighting system that ensures clear visibility for safety working practice. The apparatus is equipped with a PRO150 air purifier and a HEPA filter. It requires no external ventilation.



Applications

Chemical testing and conservation treatments

Product code	Description	Pack qty
SUEPSL1200	Epoxy Disintegrator 1 litre	1

Synperonic A7 Non-ionic SR05 Solution

Synperonic A7 is a new, environmentally friendly formula, it is an aqueous solution of condensate of nonylphenol with ethylene oxide introduced to replace the original 27% active 'N' grade which is widely and successfully used for a variety of conservation processes including as a detergent, wetting agent, surfactant, emulsifying and dispersing agent. Synperonic A7 is an alcohol ethoxylate and, like its predecessor 'Synperonic N', is a mild detergent generally used for the removal of tar and ground-in grime. In conservation, it has also been used as a wetting agent and to eradicate ground-in stains on a variety of substrates including textiles, paper, chinaware and porcelain, encaustic floor and fireplace tiles and glass. Synperonic A7 is completely miscible at 20° C with water, cellosolve, methanol, ethanol and isopropanol. Synperonic A7 is a more concentrated form of Synperonic NDB.

Specifications

Odour: mild

Appearance: white viscous liquid at 20°C

Melting point/range: approx. 21°C

Boiling temperature: product will be stable up to 120°C

Viscosity: 21 mPa.s @ 50°C

Auto-ignition temperature: 385°C

Specific gravity: 0.958 @ 50°C

pH5.66 (in aqueous solution)

Solubility in water: soluble > 10g/100g

Flashpoint: 198°C (open cup)

Soluble in water, ethanol, glycol ethers, chloroform/carbon tetrachloride, vegetable oil. Insoluble in mineral oil

Product code	Description	Capacity	Pack qty
SUSYNA0007	Synperonic A7 solution	1 litre	1

 *Linked Products: CXD Pneumatic Vacuum Table p168; Buchanan Vacuum Tables p167; Belo Vacuum Tables, Multirestor p166.*

Archival Aids Mobile De-acidification Spray Unit DA06

The mobile spray unit is a complete assembly supplied ready for use where an existing fume hood or extraction system is available. The free-standing, wheeled cabinet houses all the necessary items for spray treatment of all types of paper ephemera.

The cabinet holds 1 x 19-litre cylinder of treatment solution, 1 x 19-litre cylinder of cleaning solution and a nitrogen propellant cylinder. The cleaning solution is used to flush out the pipework and spray gun system at the end of a work period to ensure that lines are kept clear.

The spray gun is a special type particularly suited for the application of treatment solution in that it generates a liquid fan jet rather than a dispersed spray.

The jet can be controlled or changed to vary the fan size from a few inches to up to 2 feet according to the size of materials to be treated.

A specially designed solvent tank holds the gun when not in use to ensure that the tip is kept away from the air, minimising the problems of contamination and gelling of treatment solutions.

The cylinders are simple to remove and replace when empty ensuring that solutions are kept under safe, controlled conditions, reducing wastage. The unit needs little maintenance and is easy to use.

Product code	Description	Pack qty
EQAADA0600	Mobile Spray Unit	1

Protection Equipment and Accessories

Overall

Non-woven polypropylene overall with hood.
 Zip fastener. Elastic fitted waist, wrist and ankles.
 Sizes L, XL, XXL.



Product code	Description	Size	Pack qty
EQOVER0001	Overall	Size L	1
EQOVER0002	Overall	Size XL	1
EQOVER0003	Overall	Size XXL	1

Mop Cap Polypropylene Head Protection



Product code	Description	Pack qty
EQCAPP0001	Mop Cap	100

8000 Series Reusable Protective Mask

Reusable respiratory protection offering high performance at a very low price. Elaborate shape which offers the user increased comfort and keeps the field of vision perfectly clear. It is light and easy to use. Preformed heads and quick releases which allow correct adjustment. Combined filter adapted to the following types of pollutants: gas and organic and inorganic vapours, ammonia and its derivatives, gas and acid vapours. The replacement of the inhalation valves is carried out automatically with the installation of new filters, this contributes to an optimum performance and to maximum hygiene whilst requiring little maintenance.



Product code	Description	Pack qty
EQMASK8900	Gas Filter – set of 2 – EN14387:2004	1
EQMASK8002	Face Piece only	1
EQMASK8000	Face Piece + 2 Gas Filters	1
EQMASK8080	Particulate Filter	1
EQMASK8090	Disk Filter Holder – set for 2 disk	1

Carbosorb™ Plus Face Mask

Made from 100% activated charcoal cloth® the Carbosorb™ Plus Face Mask is comfortable to wear and suitable for conservators and restorers working with ceramics, photography, wood, paint, textiles and plastics. The Carbosorb™ Plus face mask has been designed to provide the following features: odour control and particulate removal; organic vapour absorption; low breathing resistance. Conforms to FFPI-EN149/2001.



Specifications

- Typical Vapours Absorbed:*
- *General Odours: Chemical, Human, Animal*
 - *Alcohols: Methanol, IPA*
 - *Ethers: Methyl, Ethyl, Butyl*
 - *Aromatic Hydrocarbons: Benzene, Toluene, Xylene*
 - *Nitrogen Compounds: Aniline,*
 - *Nitrobenzene*
 - *Acids: Acetic, Acrylic, Formic, Lactic.*
 - *Aldehydes/Ketones: Glutaraldehyde, Acetone*
 - *Aliphatic Hydrocarbons: Acetylene, Pentane*
 - *Halogens: Carbon Tetrachloride, Iodine, Trichloroethylene*
 - *Sulphur Compounds: Carbon Disulphide, Mercaptans*

[Link to Charcoal Cloth in Paper, Boards and Materials p107.](#)

Product code	Description	Pack qty
SUSMCS0000	Carbosorb™ Plus Disposable Fold Flat Mask	1

Disposable Foldable Comfort Model

Half-masks that filter solid and liquid particles. Wide field of vision thanks to vertical folding. Double elastic support. Metallic nose clip covered in plastic material. Conforms to EN149. 20-piece dispenser box. Hygienic individual wrapping. Perfect adjustment. No maintenance required. Exhalation valve facilitates comfortable breathing.

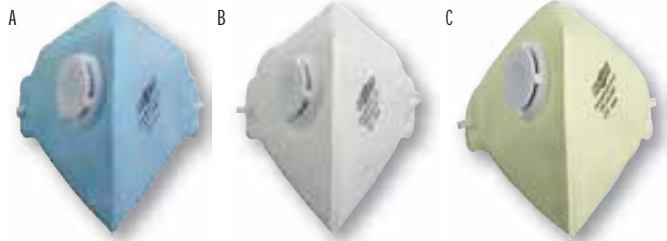

Product code	Description	Pack qty
EQMASK0001	A Half-mask FFP1	20
EQMASK0002	B Half-mask FFP2	20
EQMASK0003	C Half-mask FFP3	20

Disposable Mask with Ventex Valve

Disposable respiratory protection, against dust, smoke, highly toxic solid or liquid aerosols. Semi-mask with double shell and double clip band. Fixing system with quick release. This mask is fitted with a Ventex low-pressure valve, designed to reduce respiratory resistance and to facilitate the acceptance of the mask by its user. It reduces the heat, the humidity and the amount of CO₂ after exhalation inside the mask.



Product code	Description	Pack qty
EQMASK1000	Ventex Face Mask	1

Dust and Mould Protection Face Mask

Lightweight protection from dust and mould using this paper fibre mask from 3M.



Product code	Description	Pack qty
SUDUST7060	Dust and Mould Mask	1

Breva Eye Protection Goggles

Protective goggles with a wide field of vision. One-piece screen made of polycarbonate. Colourless lenses. Front and side protection. No image distortion. UV protection.



Product code	Description	Pack qty
EOGOGG0005	Breva Protective Goggles	1

Iroise Eye Protection Goggles

Protective goggles with a wide field of vision. One-piece screen made of polycarbonate. Colourless lenses. Front and side protection. No image distortion. UV protection.



Product code	Description	Pack qty
EOGOGG0006	Iroise Protective Goggles	1

EVApro Eye Protection Goggles

PVC mask with 4 vents. Easily-adjustable elastic band. Suitable for wearing over glasses. Colourless panoramic polycarbonate screen with anti-fog and anti-scratch treatment.

Weight: 120g



Product code	Description	Pack qty
EOGOGG0004	EVApro Protective Goggles	1

EVA03 Eye Protection Goggles

PVC mask with direct ventilation. Colourless panoramic polycarbonate screen with anti-fog and anti-scratch treatment. Easily-adjustable elastic head band.

Weight: 90g



Product code	Description	Pack qty
EOGOGG0003	EVA03 Protective Goggles	1

Electronic Noise-Cancelling Headsets

Electronic level-dependent and noise reducing headset. Sensitive microphone enables listening and communication while automatically blocking hazardous sounds. ON/OFF volume control. Ingenious space-saving folding design.

Requires two 2 AA batteries (supplied).



Product code	Description	Pack qty
EQHEAD000	Electronic Noise-cancelling headset	1

Compact Noise-Cancelling Headset

Optimal protection, with foam fitting for comfort and space-saving practicality.



Product code	Description dB	Pack qty
EQHEAD0033	Compact Model 33	1
EQHEAD0030	Compact Model 30	1

Cotton Gloves

White cotton jersey gloves for handling most documents, drawings or photographs but not recommended for handling friable items or books because the fabric can snag on loose paper or leather.

- 10 pairs per bag and in three sizes: S, M, L.



Product code	Description	Pack qty
SUCRGS0006	Cotton Gloves - Small (pair)	10
SUCRGS0007	Cotton Gloves - Medium (pair)	10
SUCRGS0008	Cotton Gloves - Large (pair)	10

KI Anti-Static Gloves

KI anti-static gloves are a remarkable blend of soft conductive and synthetic fibres. The conductive gloves suppress dust-collecting electrostatic charges when handling delicate and sensitive static prone materials.



Use for handling films, plastics, optics and glass to prevent fingerprints and scratching, also for CDs and DVDs to reduce the risk of static shocks damaging their protective varnish layer thereby exposing the reflective aluminium layer and allowing it to corrode.

When soiled, the gloves may be washed with a gentle soap or detergent and tumble-dried at the 'warm' setting.

Sold in pairs and made in three sizes, Small, Medium and Large.

Product code	Description	Pack qty
SUVAST0001	KI Anti-Static Gloves - Small	1
SUVAST0002	KI Anti-Static Gloves - Medium	1
SUVAST0003	KI Anti-Static Gloves - Large	1

Latex Gloves

Single-use latex gloves (not powdered). Ambidextrous. In a 100-piece dispenser. Ideal for dirty products and toxic substance handling or for protection from pollution and contamination.



Available in three sizes: S, M, L.

Product code	Description	Pack qty
SULAGP0101	Latex Gloves Powdered Small	100
SULAGP0102	Latex Gloves Powdered Medium	100
SULAGP0103	Latex Gloves Powdered Large	100
SULAGP0201	Latex Gloves Powder-free Small	100
SULAGP0202	Latex Gloves Powder-free Medium	100
SULAGP0203	Latex Gloves Powder-free Large	100

Nitrile Disposable Gloves

Nitrile gloves are made of synthetic latex. They contain no latex proteins and offer excellent resistance to punctures and tears. These green Nitrile gloves offer a higher degree of flexibility and have superior solvent resistance. Many uses including handling books and fragile library and archive material.



Product code	Description	Pack qty
SUNPFG7074	Nitrile Gloves Small	100
SUNPFG7571	Nitrile Gloves Extra Large	100
SUNPFG7572	Nitrile Gloves Large	100
SUNPFG7573	Nitrile Gloves Medium	100

Vinyl Gloves

White vinyl gloves with powdered interior for easy use. Smooth finish, thickness 0.1mm, length 240mm, ambidextrous fit.



Available in three sizes: S, M, L.

Product code	Description	Size	Pack qty
SUVNLG0001	Vinyl Gloves	Small	100
SUVNLG0002	Vinyl Gloves	Medium	100
SUVNLG0003	Vinyl Gloves	Large	100

Brushes

KI Anti-Static Brushes

KI short-handled, anti-static brushes dissipate static electricity and remove dust without using electricity, radioactive or chemical products. A special combination of animal hairs and conductive synthetic fibres is carefully assembled on a stainless steel mesh. The result is a dense but soft brush. Static electricity is dissipated by the conductive fibres and impurities are removed by the natural hairs.



Product code	Description	Bristle length mm	Bristle length inches	Pack qty
EQBRUS0060	KI Anti-Static Brush	60	2 ³ / ₄	1
EQBRUS0140	KI Anti-Static Brush	140	5 ³ / ₄	1
EQBRUS0280	KI Anti-Static Brush	280	11 ¹ / ₂	1

 *Linked Products: Anti-Static Gloves p215.*

Chinese Flexible Goat Hair Brushes

Soft goat's hair mounted on lightweight bamboo tubes linked together like pan pipes. They are multi-functional and, being extremely lightweight to hold, are ideal for working on large formats. The soft, flexible goat hairs are well-suited to removing dust from documents and works of art with no risk of abrasion. Used traditionally for applying water or thin pastes for mounting Chinese paintings on lightweight paper. They can also be used when framing for creating large watercolour washes on mount/mat board.



Product code	Description	Bristle width mm	Pack qty
SUBRUS0060	Chinese Flexible Brush	60	1
SUBRUS7544	Chinese Flexible Brush	80	1
SUBRUS0110	Chinese Flexible Brush	110	1
SUBRUS7543	Chinese Flexible Brush	150	1

Decorators Dusting Brushes A and B Types

A: Short-handled cleaning brush made of wild silk (soft but responsive hairs), finely mounted on a raw wood handle.

B: Small short-handled dusting brush made of horsehair with colourless lacquered wooden handle.



Product code	Description mm	Bristle width mm	Bristle width inches	Pack qty
EQDUST0225	Decorators Dusting Brush A	225	8 ⁵ / ₆₄	1
EQDUST0450	Decorators Dusting Brush B	450	17 ² / ₃₂	1

Japanese Nakasato Brush

Hand-crafted. Goats hair with a plain wooden handle. The soft, flexible hairs of these brushes allow dust to be removed from documents and works with no risk of abrasion. They are also suitable for pasting and watercolour washes.



Product code	Description	Bristle length mm	Pack qty
EQNAKA0013	Japanese Nakasato Brush	13	1
EQNAKA0027	Japanese Nakasato Brush	27	1
EQNAKA0042	Japanese Nakasato Brush	42	1
EQNAKA0070	Japanese Nakasato Brush	70	1
EQNAKA0085	Japanese Nakasato Brush	85	1

'Bright' Nylon Artist Brushes

A range of 'Bright' flat-shaped brushes with soft conical nylon bristles often selected for working with fluid acrylic paints. Nickeled ferrules on long varnished handles with a distinctive burgundy-coloured marble finish.



Product code	Description	Bristle width mm	Pack qty
EOBRUS0002	Bright Nylon Brush Very Soft	2.7	1
EOBRUS0004	Bright Nylon Brush Very Soft	4.0	1
EOBRUS0006	Bright Nylon Brush Very Soft	6.5	1
EOBRUS0013	Bright Nylon Brush Very Soft	13.5	1
EOBRUS0020	Bright Nylon Brush Very Soft	20.0	1
EOBRUS0035	Bright Nylon Brush Very Soft	35.0	1

Flat 'Filbert' Squirrel Brushes

High-quality pure grey squirrel hair in nickel-plated copper ferrules mounted on black varnished handles in a range of four sizes suitable for use with watercolour or other fluid paints. Can also be used for cleaning where an extremely soft hair is required such as dusting photographic negatives.



Product code	Description	Bristle width mm	Pack qty
EOBRUS0106	Pure Grey Squirrel Brush	6.0	1
EOBRUS0112	Pure Grey Squirrel Brush	12.0	1
EOBRUS0121	Pure Grey Squirrel Brush	21.0	1
EOBRUS0125	Pure Grey Squirrel Brush	25.0	1

'Round' Nylon Artist Brushes

A range of 'Round' shaped brushes with soft conical nylon bristles for fluid paints or adhesives. Nickeled ferrules on long varnished handles with a distinctive burgundy-coloured marble finish.



Product code	Description	Bristle diameter mm	Pack qty
EOBRUS0202	Round Nylon Brush Very Soft	2.0	1
EOBRUS0204	Round Nylon Brush Very Soft	4.0	1
EOBRUS0206	Round Nylon Brush Very Soft	6.0	1
EOBRUS0210	Round Nylon Brush Very Soft	10.0	1

'Fan' Calf Ear Hair Brushes

Fine, natural, calf ear hair, fan-shaped brushes are mainly used for varnishing and 'feathering' techniques by artists but are also suitable for re-sizing paper and other conservation applications. Seamless nickel-plated ferrules mounted on long black varnished handles. Available in three sizes.



Product code	Description	Pack qty
EOBRUS0314	No.14. Calf Ear Hair Bristle	1
EOBRUS0304	No.4. Calf Ear Hair Brush	1
EOBRUS0308	No.8. Calf Ear Hair Bristle	1

European Brushes Mop Brush

Product code	Pack qty
SUMOPB7059	1

See Papers, Boards and Materials for Japanese papers and materials.

'Fine Point' Kolinsky Sable Watercolour Brushes

Finest quality Kolinsky Sable brushes in two styles. Version A has short hair for spotting/retouching and Versions B, C and D have extra-long hair for more general painting and conservation work. Seamless nickel-plated ferrules mounted on short black varnished handles. Available in four sizes.



Product code	Description	Bristle diameter mm	Pack qty
EOBRUS0408	Kolinsky Sable Hair	0.8	1
EOBRUS0410	Kolinsky Sable Hair	10	1
EOBRUS0417	Kolinsky Sable Hair	1.7	1
EOBRUS0437	Kolinsky Sable Hair	3.7	1

'Natural Quill' Watercolour Brushes

These traditional style brushes will hold a large charge of liquid and are crafted to create an excellent point. They are made with the finest quality pure squirrel hair bound in non-corrosive natural quills secured with stainless steel wire to short, varnished wooden handles. Available in three sizes.



Product code	Description	Diameter mm	Diameter inches	Pack qty
EOBRUS0535	Pure Kazon Squirrel Hair Brush	3.5	1/4	1
EOBRUS0508	Pure Kazon Squirrel Hair Brush	8.0	5/16	1
EOBRUS0513	Pure Kazon Squirrel Hair Brush	13.5	1/2	1

Plastic Art Brushes

These useful brushes are made with soft Synthetic Sable bristles set in polypropylene plastic handles to produce a low-cost brush without risk of metal corrosion. Available in three sizes.



Product code	Description	Pack qty
EOBRUS0606	No.6. Plastic Art Brush	1
EOBRUS0614	No.14. Plastic Art Brush	1
EOBRUS0618	No.18. Plastic Art Brush	1

Chemically Resistant Synthetic Brushes

Flat decorators-style brushes made with plastic handles and ferrules. No metal to corrode and the polyester bristles are resistant to most chemicals used for conservation applications.



Product code	Description	Bristle width mm	Pack qty
EOBRUS0730	Polyester Brush	30	1
EOBRUS0740	Polyester Brush	40	1

Brushes with Metal Ferrule

Flat brushes with copper ferrules. Very soft gold coloured, tapered nylon bristle. Polished handle.



Product code	Description	Bristle width mm	Pack qty
EOBRUS0820	Tapered Nylon Bristle Brush, Very Soft	20	1
EOBRUS00840	Tapered Nylon Bristle Brush, Very Soft	40	1
EOBRUS0880	Tapered Nylon Bristle Brush, Very Soft	80	1

Extra Large Hog Bristle Paint and Paste Brush

Because this brush was recommended by a valued bookbinding customer for its quality and longevity, it has been added to the range. Extra Large Size, White Hog Bristle, 63.4mm diameter, length 103mm. Paint and Paste Brush with Nickel Ferrules, Varnished Wooden Handles.



Product code	Description	Size mm	Size inches	Pack qty
SUBRUS7710	Extra Large Round White Bristle Brush	63.4 Dia 103 Bristle Length	2 1/2 Dia	1

Japanese Brushes

These Japanese brushes are all of a traditional design and have been developed over centuries of usage and are suitable for those engaged in paper conservation.

In recent years the number of craftsmen manufacturing brushes have decreased and so have good-quality raw materials. Correct maintenance is necessary as brush performance may vary in climates that are greatly different from Japan's relatively moist temperate climate.

 *Linked Products: Japanese Paper p95-99.*

Mizu-Bake

Made from soft goat hair, the abundance of hair allows this brush to soak up more liquid. Used for spreading paste solution over large area. Also used in various dyeing, sizing and other craft techniques. Available in wide range of sizes.

- Hair - Goat
- Handle - Hinoki (Japanese cypress)
- Binding - Silk, Stainless Steel Filament.



Product code	Description	Weight g	Bristle thickness mm	Hair/bristle size mm
SUMIZU0020	Brush N°20	40	7	W55 x L28
PAMIZU0030	Brush N°30	50	8	W85 x L28
SUMIZU0040	Brush N°40	50	8	W115 x L28
SUMIZU0050	Brush N°50	70	8	W145 x L28
SUMIZU0060	Brush N°60	80	9	W175 x L38
SUMIZU0080	Brush N°80	120	9	W235 x L38

Naze-Bake

Made from hemp fibre. Used by screen craftsmen when bonding together two sheets of paper.

The Naze-Bake is also used for smoothing out air pockets. Craftsmen prepare new Naze-Bake to their own preferences, cutting corners and smoothing out the brush shape with sandpaper.

- Hair - Hemp Fibre
- Handle - Hinoki (Japanese cypress)
- Binding - Stainless Steel Filament



Product code	Description	Weight g	Bristle thickness mm	Hair/bristle size mm
SUNAZE7033	Brush N°ss	100	8	W138 x L65

Nori-Bake

Made from a mix of soft horse mane and tail hairs. A slightly harder bristle compared to the Mizu-Bake, the Nori-Bake is more suited for spreading paste and other thick-bodied materials. Available in a wide range of sizes.

- Hair - Horse (mane, tail)
- Handle - Hinoki (Japanese cypress)
- Binding - Silk, Stainless Steel Filament



Product code	Description	Weight g	Bristle thickness mm	Hair/bristle size mm
SUNORIO020	Brush N°20	35	7	W52 x L28
SUNORIO040	Brush N°40	60	8	W115 x L28
SUNORIO050	Brush N°50	60	8	W145 x L28
SUNORIO060	Brush N°60	80	8	W175 x L38
SUNORIO070	Brush N°70	200	11	W205 x L45
SUNORIO080	Brush N°80	250	13	W235 x L45

Tsukemawashi-Bake

Made from the elastic strands selected from horse tail hair. Two types are available according to hair quality. The Tsukemawashi-Bake is best-suited for spreading paste solution thinly and evenly over a wide area and for other similar precision work. The Tsukemawashi-Bake are extremely high-quality precision brushes.

- Hair - Horse (elastic soft hair from tail area)
- Handle - Hinoki (Japanese cypress)
- Binding - Silk, Stainless Steel Filament

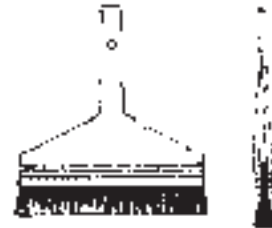

Product code	Description	Weight g	Bristle thickness mm	Hair/bristle size mm
SUTWHC7075	Brush	70	5	W140 x L25

Uchi-Bake Japanese Pounding Brush

Made from thick, tough hemp fibre, commonly known as the 'onige' or the 'devil's hair'. Used by traditional Japanese screen craftsmen for pounding together two sheets of paper into a single sheet. It takes veteran craftsmen at least two days just to bind the brush base for a Uchi-Bake.

- Hair – Hemp Fibre
- Handle – Hinoki (Japanese cypress)
- Binding – Silk



Product code	Weight g	Width mm	Thickness mm	Length mm	Height mm
SUUCHI0001	280	125	18	67	215
SUUCHI0002	500	125	30	85	235

Shashi-Bake

The reddish brown hair taken from the horse torso area is often called “camel hair” because of its colour. The Sachi-Bake is used for working with paste or colour in tight detail areas.

- Hair - Horse (Torso Area)
- Handle - Bamboo
- Binding - Cotton Thread



Product code	Description	Weight g	Bristle thickness mm	Hair/bristle size mm
SUSASH0003	Brush No. 3	2	8	W8 x L8
SUSASH0004	Brush No. 4	2	10	W10 x L10
SUSASH0005	Brush No. 5	3	14	W14 x L12
SUSASH0008	Brush No. 8	7	24	W24 x L16
SUSASH0010	Brush No. 10	9	28	W28 x L16

Shiro-Ebake

Select quality, elastic goat hair is used. Combines the natural softness and elasticity of wool. Thin brush hair length, the Shiro-Ebake is best-suited for delicate work such as in light colour coating, thin coating paste, thin paper surfacing (for screens) etc. Available in 10 size variations.

- Hair - Goat (elastic Goat hair)
- Handle - Hinoki (Japanese cypress)
- Binding - Silk

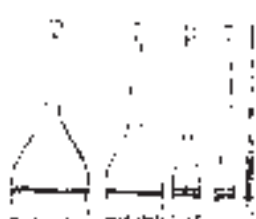

Product code	Description	Weight g	Bristle thickness mm	Hair/bristle size mm
SUEBAK0005	Brush N°5	10	6	W13 x L19
SUSHIRO012	Brush N°12	20	6	W33 x L34
SUSHIRO015	Brush N°15	30	6	W40 x L37
SUSHIRO030	Brush N°30	50	6	W85 x L40
SUSHIRO040	Brush N°40	80	6	W115 x L46

Surikomi-Bake

A very thick-bodied brush made with soft horse hair taken from the torso area. Traditionally used for daubing powdered pigment on paper and for various blending techniques. Also used for various detail work. Available in a wide range of sizes.

- Hair - Horse (torso area)
- Handle - Bamboo
- Binding - Cotton Thread



Product code	Description	Weight g	Bristle thickness mm	Hair/bristle size mm
SUSURIO001	Brush No. 1	2	3	W3 x L6
SUSURIO002	Brush No. 2	2	6	W6 x L7
SUSURIO003	Brush No. 3	3	7	W9 x L10
SUSURIO004	Brush No. 4	5	8	W12 x L10
SUSURIO005	Brush No. 5	6	8	W15 x L10
SUSURIO006	Brush No. 6	8	10	W18 x L12
SUSURIO008	Brush No. 8	13	15	W24 x L15
SUSURIO010	Brush No. 10	16	15	W30 x L15
SUSURIO012	Brush No. 12	20	15	W36 x L17

Tako-Bake

A small, thick-bodied brush made from hard deer hair. Used for brushing work in detail areas.

Originally used by traditional Japanese kite artists. The name comes from the Japanese word for kite, “tako”. The brush was used for painting black whiskers on the kite face. The thick body of the brush is ideal for drawing solid, unbroken lines.

- Hair - Deer
- Handle - Bamboo
- Binding - Cotton Thread



Product code	Description	Weight g	Bristle thickness mm	Hair/bristle size mm
SUTAKE0005	Brush No. 5	5	5	W14 x L11

Dami-Bake

Hair-weasel, handle-bamboo, binding-resin.

Made from weasel hair which is highly valued by craftsmen. The handle is carved bamboo, split at one end to attach the brush base, which is bonded with a special resin material. This is the preferred brush of traditional Japanese lacquer craftsmen, providing superior liquid absorption and making clean, even coating possible.

- Hair - Weasel
- Handle - Bamboo
- Binding - Resin

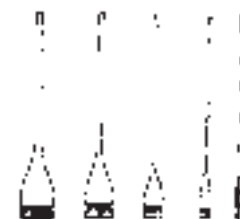

Product code	Description	Weight g	Bristle thickness mm	Hair/bristle size mm
PADAMI0010	Brush N°10	9	4	W26 x L15

Kataha-Bake

- Hair-horse (torso)
- Handle-bamboo
- Binding-cotton

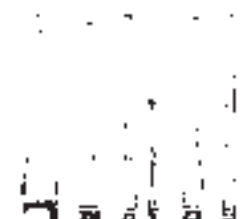

Product code	Description	Weight g	Bristle thickness mm	Hair/bristle size mm
PAKATA0010	Brush N°10	9	4	W29 x L18

Ashige-Kanamaki-Bake

Ashige-Kanamaki-Bake is made from horse hair taken from the leg area. Leg hairs are slightly harder than torso hair.

- Hair - Horse (leg area)
- Handle - Hô-no-ki
- Binding - Brass



Product code	Description	Weight g	Bristle thickness mm	Hair/bristle size mm
SUASHI0003	Brush N°3	9	4	W26 x L15
SUASHI0005	Brush N°5	8	3	W14 x L17
SUASHI0008	Brush N°8	10	3	W22 x L18
PAASHI0010	Brush N°10	13	3	W27 x L18
SUASHI0015	Brush N°15	18	4	W40 x L19
SUASHI0020	Brush N°20	21	4	W53 x L20

Lighting Equipment

Magnifying Glasses

Adjustable high-quality magnifying glass with Japanese optics.

2 x interchangeable rings.

2 models available:

- 4 x magnification, 2 optic components, covers the 24 x 36mm format.
- 8 x magnification, 4 optic components.



Product code	Description	Pack qty
EOMLGO0001	4 x Magnification	1
EOMLGO0002	8 x Magnification	1

Folding LED Linen Tester Magnifier

This LED illuminated folding magnifier has 2.5 magnification, 80mm diameter lens and black plastic base. It is portable and battery operated – 4 AA batteries are included.

- Dimensions (open): 125 wide x 95 deep x 135mm high
- Dimensions (closed): 125 wide x 95 deep x 45mm high
- Cut out in base: 60 x 60mm
- Magnification: 2.5 x



Product code	Description	Pack qty
EOMAGN0003	2.5 x Magnification	1

30 x Microscope Magnifier

A powerful 30 x magnification mini-pocket microscope made of moulded plastic.

The built-in bulb projects concentrated light directly onto the object making it easier to observe.

The focus settings can be adjusted using a thumb-wheel. It is also fitted with a retractable magnifier which enlarges by 8 x. A light, practical instrument, offering excellent performance.

30 x microscope magnifier – including batteries. Supplied with 4 LR6 batteries and transportation case.

Weight: 125g

Dimensions: 140 x 45 x 20mm



Product code	Description	Pack qty
EOMAGN0030	30 x Magnification	1

Folding Linen Tester Magnifier

Convenient, small, fold-away magnifier with black metallic body and biconvex, optically ground silicate glass lenses.

- Ø: 27mm
- Dimensions (open): 52 wide x 38 deep x 52mm high
- Dimensions (closed): 52 wide x 38 deep x 12mm high
- Cut out of base: 27 x 27mm
- Magnification: 6x



Product code	Description	Size mm	Size inches	Pack qty
EOMAGN0018	Folding Linen Tester	Ø 27	Ø 1 1/8	1

Binocular Magnifiers COMFORT Model

Quality binocular magnifier with Velcro® adjustable headband. Supplied with two sets of super-imposable lenses, providing 3 magnifications: 2.2, 3.2, 4.5. The two lens sets are inside the visor: one only needs to place the second set on the first to obtain the different magnifications.



Product code	Description	Pack qty
EQLOVCO002	Binocular Magnifiers	1

Binocular Magnifiers STANDARD Model

Lightweight (160g) binocular magnifiers. Adjustable using Velcro® strap. Two sets of lenses which can be stacked by tilting, offering 1.8 and 2.3 x enlargements. 1 x third swivelling outer lens which adjusts to the stackable lenses and increases the enlargement to 4.8 x.



Product code	Description	Pack qty
EQLOVSO003	Binocular Magnifiers	1

CeeLite® LEC Flexible (1mm) Light Sheet

The new conservation lighting phenomena from Conservation By Design

CeeLite® LEC Technology-based lighting products are different from existing lighting sources and represent a separate category of products from anything currently available in the lighting industry.

Conservation By Design identified the uses of CeeLite® for conservation and have been appointed by CeeLite® as distributors to the conservation community. The super-thin flexible CeeLite® sheet is less than 1mm thick, emits no UV radiation and negligible heat whilst lit even when used for hours or days at a time. The unit provides an even light over the whole surface up to 200 candelas/m² with no dark spots. CeeLite® LEC panels have a surface hard enough to be worked on and are perfect for many conservation-related tasks. They can be used to view watermarks in books or backlight pages for in situ repairs without damaging the spine. They are ideal for viewing photographic negatives, backlighting and illuminating damaged areas of paintings or textiles and being flexible they can be rolled to fit inside hard-to-reach areas such as costume sleeves or other three-dimensional objects.

As they are so lightweight, they are also quite portable allowing several conservators within an institution to share a light source and use the LEC panel in their own workspace without having to transport fragile objects to a shared light table. They can also be used for long-term exhibition and informational signage lighting.

How the technology works

The technology principles underlying the LEC panels has its genesis in an older proven technology, known as electroluminescence ('EL'). However, the platform LEC technology is distinguished from traditional EL technology in many ways, including the fact that the LEC panels provide whiter light without a blue cast, have a significantly longer life, provide a more uniform illumination across their surface, emit less noise and electromagnetic interference ('EMI'), utilise power inverters to regulate power output and maintain a more constant brightness and contain certain safety features not contained in traditional EL lighting products. Lighting products utilising LED and OLED technologies produce light by combining multiple smaller points of light into a larger light source. The platform LEC technology is distinguished from LED and OLED

technologies in that the LEC panels produce a uniform source of light in a single pixel format without multiple points of electrical connection, across a larger flexible area, are visible from a wide angle, are more durable and are not sensitive to vibration. LEC panels also produce light that ensures the colour accuracy of the illuminated surface or object.

Stock and special sizes

CeeLite® LEC panels are available from CXD stock in standard A4 and A3 sheets but can be specified to special order in much larger sizes for use as light tables, light walls and use in frames, showcases or wherever the imagination leads.

CeeLite® LEC Regular Stock and Standard Sizes

A4 297 X 210mm (11.7" x 8.3") Regular stock size.

A3 420 X 297mm (16.5" x 11.7") Regular stock size.

A2 594 X 420mm (23.4" x 16.5") Limited availability stock size.

406 X 508mm (16" x 20") Limited availability stock size.

457 X 610mm (18" x 24") Special order.

610 X 610mm (24" x 24") Special order.

559 X 711mm (22" x 28") Special order.

610 X 914mm (24" x 36") Special order.

610 X 1,219mm (24" x 48") Special order.

914 X 1,219mm (36" x 48") Special order.

914 X 1,524mm (36" x 60") Special order.

914 X 1,829mm (36" x 72") Special order.

Other sizes on request.

All CeeLite® LEC panels come with the appropriate size inverter, proprietary light source, wall socket power cord and are thereby ready for immediate use.

Product code	Description	Pack qty
EQLSCP0003	Light Sheet A3	1
EQLSCP0004	Light Sheet A4	1



Quasar™ Lightboxes

Combining stylish design and high performance. The Quasar™ is made from a lightweight aluminium extrusion, with carry handle and is available in sizes A4 to A2 with optional larger sizes. The curved upper profile and flush-fitting screen aid comfortable working without creasing larger material being worked on. All Quasar™ lightboxes have a stylish 'silver hammer' finish with 'aqua' colour body striping.

Colour Temperature = 5000k (+/-10% k)



Options

Opal acrylic or glass/opal acrylic screen on A4 to A1
 Glass/opal acrylic only on A0 and 60 x 40 lightboxes
 Stage dimmer only on 60 x 40 lightboxes
 On/Off or stage dimmer switch on A2 and A0
 On/Off switch on A4 and A3 models

Product code	Description		Size mm	Size inches	Pack qty
EQLBQU0103	Quasar™ Lightbox	A3	346 x 500 x 90	13 ⁵ / ₈ x 19 ¹ / ₁₆ x 3 ⁵ / ₆₄	1
EQLBQU0104	Quasar™ Lightbox	A3	346 x 500 x 90	13 ⁵ / ₈ x 19 ¹ / ₁₆ x 3 ⁵ / ₆₄	1
EQLBQU0106	Quasar™ Lightbox	A2	500 x 646 x 90	19 ¹ / ₁₆ x 25 ¹ / ₁₆ x 3 ⁵ / ₆₄	1
EQLBQU0108	Quasar™ Lightbox	A2	500 x 646 x 90	19 ¹ / ₁₆ x 25 ¹ / ₁₆ x 3 ⁵ / ₆₄	1
EQLBQU0110	Quasar™ Lightbox	A1	646 x 945 x 120	25 ¹ / ₁₆ x 37 ³ / ₆₄ x 4 ² / ₃₂	1
EQLBQU0113	Quasar™ Lightbox	A0	945 x 1267 x 120	37 ¹³ / ₆₄ x 49 ¹ / ₈ x 4 ² / ₃₂	1

 *Linked Products: Workshop Furniture p232-240.*

Champlan™ Tilting Lightboxes

White enamelled lightbox with straight square sides. It can be angled with a simple tilting device. Light diffusing top in methacrylate and glass. Light with balanced fluorescent tubes, 5000°k - 220v.

2 sizes 500 x 650mm and 650 x 900mm.

4 models, of which 2 are fitted with dimmer switches.



Product code	Description	Size mm	Size inches	Pack qty
EQLBST5065	Champlan™ Lightbox	500 x 600	19 ¹ / ₁₆ x 23 ⁵ / ₈	1
EQLBST6590	Champlan™ Lightbox	650 x 900	25 ¹⁹ / ₃₂ x 35 ¹ / ₁₆	1
EQLBSD5065	Champlan™ Lightbox - dimmable	500 x 600	19 ¹ / ₁₆ x 23 ⁵ / ₈	1
EQLBSD6590	Champlan™ Lightbox - dimmable	650 x 900	25 ¹⁹ / ₃₂ x 35 ¹ / ₁₆	1

PlanoLux™

Conservation Light Wall for Maps, Posters and Large Artwork



The PlanoLux™ Conservation Light Wall is based on the CXD anodized aluminium Planorama® and Framorama™ storage and display system. It is a large drawer fitted with fluorescent lights which is then mounted vertically in a Planorama® cabinet. The drawer and cabinet are covered by the Framorama™ profile fitted with opalescent acrylic designed to diffuse the light and with glass to make a smooth, scratch-resistant working surface for the conservation of large maps, posters or artwork.

The Planorama® drawer can be slid out to facilitate easy changing of the lights. The cabinet is mounted on a support frame which is fitted with guttering to take away water used in the washing and treatment of objects.

Every PlanoLux™ is custom-made, therefore special sizes and modifications can be specified.

PlanoLux™ is normally mounted against a wall but a free-standing unit could be supplied if required.

PlanoLux™ offers a functional, stylish and adaptable solution for large wet treatment conservation studio lighting.

Please contact the CXD project team for more information.

Applications

Conservation of large works on paper: maps, posters and large artwork.

PlanoLux™ can also be supplied for Display and Exhibition use.

Customer Reference sites:

Hull City Archives, Conservation Studio
 Worcester Library Conservation Studio
 Glasgow University Library Conservation Studio

PlanoLux™ Standard size: Maximum usable size (illuminated area) 3000 wide x 2000mm high.

Overall size of this unit would be: 3070 wide x 300 deep x 2770mm high including plinth which is 700mm high.

NB - PlanoLux™ are made to order therefore please contact the CXD project team for more information

Schott KLI500 LED

The KLI500 LED is an innovative fibre optic light source which uses cold light to illuminate all types of objects. The brightness is equivalent to a 150 watt halogen lamp and therefore optimised as a standard illumination system for the requirements of all stereo microscopes.

Efficient heat management is assured by an extremely silent fan. The lifetime of the LED is at least 50,000 hours. Emitting neutral white light (approx. 6,000k) the ripple-free illumination is perfect for numerous applications including digital imaging.

An additional benefit is that the colour temperature does not change when the light source is dimmed. The KL 1500 LED combines all the advantages of LED light with the advantages of illumination through fibre optics.

Significantly higher light intensities can be focused to a very small field of view. The KLI500 series light guides can all be connected to the KLI500 LED.

Product code	Description	Pack qty
EQFOKL1500	A KL1500 LED Fibre Optic Light	1
EQFOKL1501	B Single Branch 600mm gooseneck light guide	1
EQFOKL1502	C Dual Branch 600mm gooseneck light guide	1
EQFOKL1510	D Focusing Lens for light guides	1
EQFOKL1511	E Daylight Filter for light guide focusing lens EQFOKL1510	1

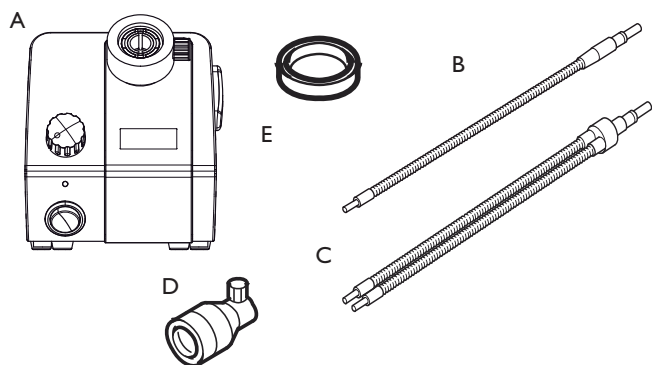

Schott KL 200

A small and economical 20w halogen cold light source, the KL200 incorporates all of Schott's high technology – with fewer drawbacks and its modern design. It is the best choice for a variety of lighting applications in the fields of microscopy, macroscopy and photography.

- Intensity regulation using a 3-position control
- Easy and safe bulb changing
- Quick-change light conductors which allow for easy handling of the housing.

Product code	Description	Pack qty
EQFOKL0200	G KL200LCD Fibre Optic Light	1
EQFOKL02300	H Filter Holder	1
EQFOKL02306	I Daylight Filter for KL200LCD	1
EQFOKL01701	J Single Branch 500mm gooseneck light guide	1
EQFOKL01702	K Dual Branch 500mm gooseneck light guide	1
EQFOKL01231	L Replacement Fuse for KL200LCD	1

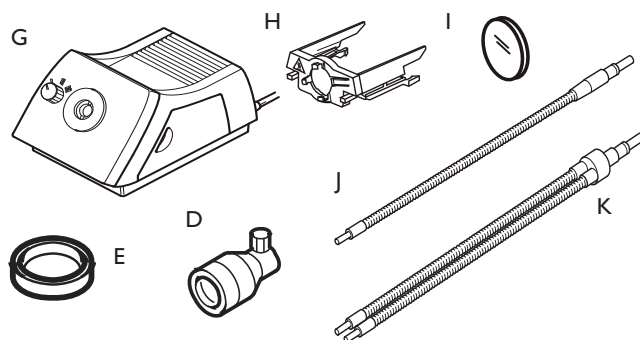

LI Task Light

The LI has been in production since 1937 and remains a firm favourite with designers, architects and the general public. LI has deservedly been heralded as a classic and has been awarded many prizes for its timeless archetypal design including the Illinois Institute of Technology Fortune's list, which considered it one of the 100 best products ever made.

LI is available in black, silver-grey or white and supplied complete with a desk clamp. An optional, weighted desk base is available.

The arm is constructed using external springs and is easily adjusted to the required working position.

Light source: (not included). Any 60w ES-type (Edison Screw) lamp is suitable. Alternatively, an energy-saving 12w ES fluorescent lamp may be used. A light source with colour temperature 6,400k/550 lumens with an 8,000 hour lifetime can be supplied on request.



Product code	Description	Pack qty
EQLBTL4983	L1 White Task Light	1
EQLBTL4986	L1 Black Task Light	1
EQLBTL4989	L1 Silver-Grey Task Light	1
EQLBTB4994	White Table Base for L1	1
EQLBTB4995	Black Table Base for L1	1
EQLBTB4996	Silver-Grey Table Base for L1	1

Task Lighting

The Memo range produces light up to 1200 Lux from a compact 13w fluorescent lamp for use in workshops and offices. These consume 30% less energy than comparable fluorescent lights and 82% less than a traditional incandescent lamp. The smooth, self-balancing arm makes it easy to adjust and move to where it is needed.



Specifications

- Max Lux: 1200
- Watt: 1 x 13
- Weight: 2.6kg
- Arm Length: 660mm
- Lumen: 900
- Colour rendering: 80
- CE
- IP20

Product code	Description	Size mm	Size inches	Pack qty
EQTLM0402	Blue	660	25 ³ / ₆₄	1
EQTLM0202	Black	660	25 ³ / ₆₄	1
EQTLMB5103	Base	660	25 ³ / ₆₄	1

[Linked Products: Workshop Furniture p232-240.](#)

LED 003 Vari-Beam Task Light

The versatile LED 003 table light can be used either as a spot or broad area light.

LUXEON® K2 LED lamps are used and guarantee a constantly high-quality illumination with a service life of up to 50,000 hours or around six years of continuous operation, impervious to shock and vibration and high colour temperature of the LEDs promotes concentration and precision.



Specifications

- High performance LED technology
- 50,000 hours maintenance-free operation
- Optional beam angles of 10° or 40°
- Low-voltage 24V AC or DC operation
- Waterproof models available up to IP67
- High resistance to coolants/lubricants
- Impervious to mechanical vibration
- Rugged aluminium housing
- Pivoting head with magnetic base provides portable illumination - two versions are available
- Articulating arm, designed for big surface restoration work, maximum extension is 80cm
- Gooseneck arm, maximum extension is 60cm, this allows for quick and easy movement

Product code	Description	Size mm	Size inches	Pack qty
EQLLED1003	With Actuating Arm	600	23 ³ / ₆₄	1
EQLLED1004	With Gooseneck	600	23 ³ / ₆₄	1

[Linked Products: Workshop Furniture p232-240.](#)



Wave LED

Wave LED offers shadow-free magnification with light coming from both sides, in addition to three-dimensional magnification with light coming from the left or right. The 3D-feature is especially welcome when working with delicate objects. With its rectangular lens, Wave LED is also suitable for reading purposes. Available in white or light grey.

Supplied with 2 x 6w integrated LED modules with correlated colour temperature (CCT) of 4000° and colour rendition index (CRI) of 80, providing a natural, even light. Also features dimmable light and energy-saving function to automatically turn themselves off after four or nine hours.

The standard version is supplied with a 3.5 dioptre glass lens, 5 dioptre alternative available on request. A cloth cover is provided to protect the lens from dust and to prevent the luminaire from inadvertently focusing sunrays.

The flexibility of the joint between lamp head and arm makes exact positioning easy. The spring balanced arm provides maximum vertical and horizontal movement, and will always stay in the right position without drifting.



Product code	Description	Colour
EQIMWL1035	3.5 dioptre, 4000° CCT, CRI 80	White
EQIMWL2035	3.5 dioptre, 4000° CCT, CRI 80	Light Grey

Circus

Circus was originally designed for demanding work in clinics and laboratories, and as a tool for people with impaired vision. Circus has a large lens, aluminium head and a highly flexible self-balancing arm and shade neck. The large lens permits comfortable viewing with both eyes.

This excellent magnifier's light source boasts corrected colour temperature of 4000° and Colour Rendition Index (CRI) of 85.

Circus has a highly flexible, self-balancing shade neck. The shade neck can be positioned horizontally, vertically and laterally making the luminaire very flexible for most examinations. The fully covered, spring-balanced arm makes it easy to position the luminaire in the correct position and makes cleaning easy. Circus comes complete with the hinged sun cover.

Offered in white with a 3.5 dioptre lens plus table clamp. A 5 dioptre version is available on request.



Product code	Description	Colour
EQIMCS5989	3.5 dioptre, 4000° CCT, CRI 85	White

Magnifying Lamps SN Model

Lamp with a top-of-the-range magnifying glass fitted with three, compact, fluorescent 9w tubes, with electronic ballast built into the vertical arm. The electronic ballast gives some very useful advantages: energy-saving of around 22% in comparison with conventional ballasts and tube-life increased by up to 50%; better safety with automatic shutdown if there are defective sources, instant high lighting comfort without flashing and no stroboscopic effect or flickering.



Specifications

- 3 dioptre magnifying glass, made of ground glass with a large field of vision and system of lighting by selective switching of the light sources thus allowing all types of control
- The magnifying glass is adjustable thanks to a ball joint, tri-directional reflector joint. The rear light source can, if desired, be used either with or without shadow projection

Product code	Description	Pack qty
EQIMSN0319	Magnifier, white	1
EQIMSN0320	Magnifier, white with electronic ballast	1
EQIMSN0004	Additional lens; 4 dioptre	1
EQIMSN0048	Additional lens; 8 dioptre	1
EQIMSN0023	Replacement light source for SN illuminated magnifier	1

Magnifying Lamps FM 101 Model

Top-of-the-range lamp fitted with a 3 dioptre magnifying glass and featuring a tri-directional head thanks to the ball joint which allows movements on two or three planes.



Specifications

- ABS head
- Lacquered steel arm, balanced by internal spring
- Maximum extension 1300mm
- Lighting by circline 22w fluorescent bulb
- Bi-convex 3 dioptre circular lens (enlargement 1.75 x)
- Possibility of additional 4 and 8 dioptre lenses (enlargement 2 x and 3 x)
- Ballast in the lower arm
- Switch on the head
- Can be fixed to a table by vice grip
- Adaptable on Luxo support

Product code	Description	Pack qty
EQIMLF1055	White with Table Clamp	1
EQIMLF0055	Light Grey with Table Clamp	1
EQIMLF0004	Additional lens, 4 dioptre	1
EQIMLF0008	Additional lens, 8 dioptre	1
EQIMLF0022	Replacement Light Source for LFM 101	1

Studio Task Lamp STE III

A task light fitted with 2 UV shielded, daylight, fluorescent tubes. Thanks to the lamp head's ball joint, it can be easily adjusted to give a comfortable working position. The support arm can be locked using the ergonomic finger screws. A chrome-plated parabolic screen incorporated into the lamp head avoids unpleasant dazzle. It can be table-mounted or fitted to an optional Waldmann mobile floor support with five locking wheels. A clip-on, 4 dioptre magnifying glass, with a large field of vision is a very useful option.



Specifications

- ABS lamp head
- 2 x 8 w 'daylight' fluorescent light tubes
- Dimensions of the head: 326 x 116 x 50mm
- Articulated arms 400 + 350mm
- Opaque diffuser
- 1.5m mains lead
- Built-in ballast and vice grips for fixing onto a table
- Adapted ready to fit to a Waldmann mobile floor support with five locking wheels

Product code	Description	Size mm	Size inches	Pack qty
EQLSTE1111	Workshop Light with UV filter and table fixing clamp	326 x 116 x 50	23 ³ / ₄ x 4 ⁷ / ₈ x 1 ⁷ / ₂	1
EQLSTE1112	Replacement Light Source for STE111	400 + 350	1 ⁵ / ₈ + 13 ⁵ / ₂	1
EQLSTE1113	Additional Lens, 4 dioptre	1.5m	59 ¹ / ₂	1

Studio Task Lamp STE136

The STE136 features a wide aluminium housing for maximum light distribution over large work areas. It features a compact 36w daylight fluorescent bulb. The luminaire head has a built-in parabolic louvre to provide glare-free illumination and precise light direction. It can be table-mounted or fitted to an optional Waldmann mobile floor support with five locking wheels.



Specifications

- 1 strip light tube of 36w
- Built-in electronic ballast for energy efficiency
- Dimensions of the head: 550 x 77 x 52mm
- Articulated arms 360 + 400mm
- Opaque diffuser
- 3 metre cable
- Built-in ballast and vice grips for fixing onto a table
- Adapted ready to fit to a Waldmann mobile floor support with five locking wheels

Product code	Description	Pack qty
EQLSTE1361	Light and Table-fixing Clamp	1
EQLSTE1362	Additional Lens, 3 dioptre	1

Vista Model

A low-cost magnifier with cold light, 3 dioptre rectangular lens fitted with a sliding protective guard. Steel spring arm. Thermoplastic head. Switch on the head. Fitted with a compact 9w fluorescent tube. Total extension 950mm.



Specifications

- Plastic head
- Lacquered steel arm, balanced by internal spring
- Maximum extension of 700mm
- Can be fixed to a table by vice grip
- Adaptable on Luxo support

Product code	Description	Pack qty
EQVISI0001	Magnifier Luminaire – 3 dioptre	1

Tevisio LED Magnifier Luminaire

Ideal for delicate conservation work, Tevisio helps wherever eyes are put to the test. It applies ergonomic perfection to support highly demanding visual tasks.

With the latest LEDs, innovative arm technology and a visual field designed for optimum performance, the Tevisio magnifier luminaire combines high efficiency with ergonomic design in the workplace.

Compared with conventional magnifier luminaires, Tevisio is 40% more efficient while maintaining high illuminance levels. At an illumination level of 6,000 lux the power consumption is only 14w.

The long LED life of up to 50,000+ hours saves on maintenance and downtime costs. This makes Tevisio highly economical to operate. For maximum operating flexibility, Tevisio is offered in a choice of two arm lengths, see table below for details.

Specifications

- 48 x LED
- Power consumption 14w
- Colour temperature neutral white 4,000k
- Light guidance via reflector
- Glass lens Ø 153mm with 3.5 dioptre magnification + 8 dioptre (additional lens)
- Housing made of anodised aluminium and black high-performance plastic



Product code	Description	Pack qty
EQLTVO0001	Grand Model, 3.5 dioptre and additional 8 dioptre Magnifier	1
EQLTVO0002	Grand Model, 3.5 dioptre and additional 8 dioptre Magnifier Dimmable, with Variable LED Segment Switching, 38.9" Reach	1
EQLTVO0003	Mini Grand Model. 3.5 dioptre and additional 8 dioptre Magnifier	1
EQLTVO0004	Mini Grand Model. 3.5 dioptre and additional 8 dioptre Magnifier Dimmable, with Variable LED Segment Switching, 38.9" Reach	1

Roller Base Luxo Model

Quintuple foot made of cast iron and metal pole. White epoxy paint, anti-static wheels. An especially rugged, stable rolling base which can hold the FMI01 or Wave lamps.



Product code	Description	Pack qty
EQIMTB5205	White. For Luxo task lights and illuminated magnifiers	1

Roller Base Luxo Model

Roller with five chrome-plated branches, suitable for fixing STE111, SN319 and STE136.



Product code	Description	Pack qty
EQLSTE0001	For STE111, STE136 and SN319 task lights	1

Light Roof

Hanging lightbox especially developed for working areas which require natural light over a particularly large area. Even lighting of a quality comparable to daylight, (around 6500k) fulfils the conditions required for great working comfort and accuracy. As the tubes need to be replaced after around 2000 hours because of the spectrum variations, an hours-of-operation counter is built into the case.

Specifications

- Lacquered box, suspension by 4 adjustable height chains
- Built-in hours-of-operation counter
- Lighting by means of four 36w fluorescent tubes
- 5m mains lead (16ft 4^{27/32})



Product code	Description	Dimensions cm	Dimensions inches	Pack qty
EQLALE4581	Model 458	166 x 66 x 14	65 ²³ / ₆₄ x 25 ⁴³ / ₆₄ x 5 ³³ / ₆₄	1
EQLALE4582	Model 458 Replacement Light Source			1
EQLALE4361	Model 436	130 x 66 x 14	51 ¹³ / ₁₆ x 25 ⁴³ / ₆₄ x 5 ³³ / ₆₄	1
EQLALE4362	Model 436 Replacement Light Source			1

Studio Luminaires

The highly efficient reflector design maximises the available light and creates a remarkably even light spread. Light is dimmable and incorporates a 100kHz electronic ballast to ensure flicker-free operation.

The stylish thermal design and ventilation of the studio light ensures very cool running, maintaining colour temperature and light output over long periods of operation.

Please contact us for more information on detachable grids, softboxes, intensifiers and barn door attachments.



EOSSLUK1455



EOSSLUK1855

Product code	Description kHz	Pack qty
EOSSLUK1455	Studio Luminaire SL455DMX – 4 x 5400 Lamps	1
EOSSLUK1855	Studio Luminaire Model SL855DMX – 8 x 5400 Lamps	1

 [Linked Products: Workshop Furniture. p232](#)

DLI00 Dermlite, Magnified Inspection Light

By incorporating diode lighting technology for bright-white, natural illumination, a 10x Hastings Triplet lens and advanced cross-polarisation technology, DLI00 allows for a clear and deep inspection of works of art on paper or other surfaces. Battery operated.

The well-fitted sleeve, made from high-quality silicone adds drop and scratch protection to DLI00, useful when working in the studio or on site. Whilst the sleeve's soft, non-slip material feels comfortable in your hand, its eyelet allows you to wear your DLI00 around your neck. Also available, the black pouches for complete protection of the DLI00 device.



Product code	Description	Pack qty
EODDLL0100	DL100 Magnified Inspection Light	1
EODDLP0100	Pouch for DL100	1
EODDLS0100	Silicone Sleeve for DL100	1

Nikon SMZ745 and SMZ445 Stereoscopic Microscopes with Zoom

The SMZ745 and SMZ445 by Nikon were developed to respond to the demand for a product at the very summit of technology that could offer high-level performance at a reasonable price. Design studies led to improved convenience and observation without input acting negatively on the system's operating modes.



- Lens with built-in dioptre adjustment
- Large-format, profiled base which facilitates use without removing your hands from the microscope; ergonomic height adjustment
- Adjustment wheel situated under the column for quick and efficient servicing
- Airtight to avoid contamination from dust, grease or water
- Protected against mould build-up: the microscope can be used in warm, humid environments
- Electrostatic protection for enhanced performance (the SMZ645 is designed to remove static electricity build-up almost instantly)

Specifications	EOMCRS7451	EOMCRS4451
Optical system	Twin zooming objective	
Zooming range	0.8x to 5x	0.8x to 3.5x
Eyepieces	10x(supplied) 15x(option) 20x(option) 30x(option)	10x(supplied) 15x(option) 20x(option)
Total magnification	6.7x to 50x (with supplied eyepiece)	6.7x to 50x (with supplied eyepiece)
Total magnification	6.7x to 50x (with supplied eyepiece)	6.7x to 50x (with supplied eyepiece)
Eyepoint level	45°	45°
Working distance	115mm	115mm
Zooming ratio	7.5 : 1	4.4 : 1

Product code	Description
EOMCRS7451	Microscope SMZ745: Focusing stand, zooming body, 2 eyepieces and 2 rubber eyeguard
EOMCRS4451	Microscope SMZ445: Focusing stand, zooming body, 2 eyepieces and 2 rubber eyeguard

Anti-UV Fluorescent Tube Sleeves

Protects displays and storage areas from fading and deterioration caused by ultraviolet light given off from fluorescent lighting. This plastic jacket has virtually the same light transmission in the visible light spectrum as ordinary window glass. However, it stops practically all the harmful ultraviolet light. Engineered to fit the standard 590mm fluorescent tube but can be cut for smaller sizes or used in pairs for longer tubes.



Product code	Size mm	Pack qty
SUFLUV0012	1200	1

VISTA Portable UV Light Inspection Magnifier

Portable magnifier light fitted with a compact 9w UV fluorescent tube.



The ultraviolet rays have a wavelength of almost 360Nm, with no risk for the skin or eyes. Sturdy thermoplastic construction, featuring a rectangular lens made of 3 dioptre glass (60 x100mm) and rigid handle.

Product code	Description	Pack qty
EQLVST0001	Illuminated UV Light	1
EQLVST0002	Replacement UV Light Source for Vista UV Light	1

UV Crystal Anti-UV Adhesive Polyester Film

A specially designed film offering a noticeable reduction in the amount of both ultraviolet and, to a lesser extent, infrared radiation entering a room.

Its main application is on glass in exhibition halls and other places where the harmful effect of UV light needs to be reduced.

Specifications

- Adhesive-coated, transparent polyester film with UV protector
- Thickness: 25µ
- Can be fitted on the inside or outside on all types of smooth glass
- UV filtering: 99.5%
- Visible light reflection: 9%
- Infrared rejection: 14%
- Anti-scratch treated

Product code	Size m	Size inches	Pack qty
PYUVCRO001	1.22 x 30	48 1/2 x 98ft 5/64	1
PYUVCRO002	1.22 x 10	48 1/2 x 32ft 5/64	1
PYUVCRO003	1.22 x 5	48 1/2 x 16ft 4 7/32	1

UV LED Torches

Portable UV torches with aluminium bodies. Impermeable, light and compact. Equipped with UV LED spotlights, these torches guarantee constant lighting throughout their batteries' lifespan, ie for 50,000 hours.



2 models available:

- TL41UV, fitted with 41 spots, ideal for lighting big surface areas.
- TL9UV, fitted with 9 spots, small and compact, easy to transport.

Specifications

- Wave length: 380-400nm
- Size: TL41UV: 14.3 x 5.3cm; TL9UV: 10 x 2.7cm
- Supplied with AAA batteries (3 for TL9UV and 4 for TL41UV)

Applications

Detection of repainting and touch-ups on paintings. Checking and detecting Optical Brightening Agents (OBAs) in paper and board, highlighting faded text.

CAUTION:

You are strongly advised to wear glasses with UV protective treatments and when using these UV torches. See page 214 for the range of anti-UV glasses.

Product code	Description	Size mm	Size inches	Pack qty
EQLEDT0009	Small. Comprises 9 LEDs	100 x 27	3 7/16 x 1 1/16	1
EQLEDT0014	Large. Comprises 41 LEDs	143 x 53	5 5/8 x 2 1/2	1

Cold Storage

Conservation By Design Cold Storage

Conservation By Design (CXD) have brought together selected individuals with specific photographic conservation and refrigeration expertise to complement the conservation storage expertise of CXD, with the aim of providing bespoke, integrated cold storage solutions for the conservation market.

Modern synthetic materials are degrading at an ever-increasing rate and cold storage is now widely accepted as being the best way of preserving photographic and special museum collections for future generations.

Consultancy

By developing a strategic partnership with another Royal Warrant holding company specialising in refrigeration, CXD now offer the conservation market a wide variety of cold room solutions.

Cold rooms can be furnished with shelving, drawers, boxes and envelopes according to the needs of the customer.

Conservation

To complete the service and ensure that the best conservation advice is given, CXD have Nicholas Burnett of Museums Conservation Services Ltd as our cold storage conservation consultant. Nicholas is renowned for his knowledge of photographs and their conservation and is experienced across the spectrum of Museum and Archive collections.

Special Museum Collections

Plastics and synthetic materials

Museums, Libraries and Archives contain a huge variety of items that can benefit from reduced temperature and controlled humidity storage.

They can range from:

- 20th century furniture
- Interior décor, scientific
- Industrial and military objects
- Contemporary sculpture and artwork

Storage of vulnerable photographic collections

Still images or motion pictures, film and photographic archives throughout the world are fighting to preserve their collections. Among the most at risk are the following types of film typically requiring cold storage:

- Cellulose nitrate film negatives
- Cellulose acetate film negatives, 'safety film'
- Dye-based colour material

Technical Information

Freezing slows the rate of decay of the afore-mentioned 'high-risk' materials. Storage at -18°C slows decay by a factor of 1000, however it makes access difficult and impractical. Reducing the temperature to just above freezing still offers significant benefits whilst minimising difficulties of access.

Typically CXD suggests aiming at 2°C and 30-40% RH (ie 35% +/- 5%) for the previously mentioned types of film. Although a lower RH does offer benefits in terms of chemical stability, a slightly higher RH of 35-40% will give greater dimensional stability and this can be decided during consultation.

Key issues when considering cold storage

- What is being stored
- Size of room required*
- Required temperature
- Required RH%
- How often is access needed and what is the balance between ease of access and what is best for the collections
- What are the local/national environmental conditions, those of the building and where will the cold storage room be situated. All of which will affect the equipment required to meet specification

*The smallest room CXD currently offer is (W x D x H) 2m x 3m x 2.4m



Sliding Door and Window



Secure Locking Handle



Hinged Door and Window

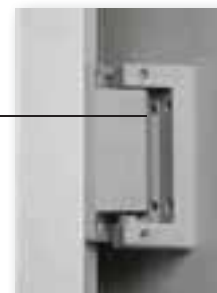

Heavy-Duty Hinges

A small selection of highly energy-efficient, reliable, professional-quality refrigerators for small collections where installation of a CXD Cold Room is not feasible.

The heavy-duty steel cabinet design provides rigidity, energy-efficiency and incorporates a sleek, touch-screen control panel for ease of use. The large screen displays the temperature ensuring you are always aware of the internal environment of collections.

Offered in two sizes, with either a single or double door.

Professional-Quality, Single-Door Photo Refrigerator

Specifications

Description: Single-Door Refrigerator
External dimensions: 700mm x 820mm x 2080mm (w x d x h)
Capacity: 600 litres
Refrigerant: R134a or Hydrocarbon
Ambient operation: The unit is designed to operate between +1/+4°C, in a maximum ambient temperature of 43°C (exceeding ISO Climate class 5)
Exterior finish: 304 stainless steel door and unit cover
Door finish: 304 stainless steel exterior
Interior base finish: 304 stainless steel
No of shelves: 3 x 2/1 GN size
Floor fittings: Castors as standard
Electrical supply: 230V 50Hz 1Ph



Professional-Quality, Double-Door Refrigerator

Specifications

External dimensions: 1440mm x 820mm x 2080mm (w x d x h)
Capacity: 1350 litres
Refrigerant: R134a or Hydrocarbon
Ambient operation: The unit is designed to operate between +1/+4°C, in a maximum ambient temperature of 43°C (exceeding ISO Climate class 5)
Exterior finish: 304 stainless steel door and unit cover
Door finish: 304 stainless steel exterior
Interior base finish: 304 stainless steel
No of shelves: 6 x 2/1 GN size
Floor fittings: Castors as standard
Electrical supply: 230V 50Hz 1Ph



Books and DVDs on Conservation and Preservation

Many informative publications are available from CXD. Please check our website for the latest titles available.

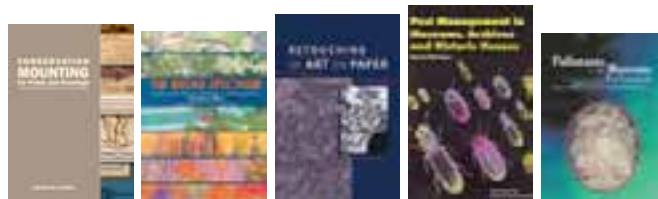

PHOTOGRAPHIC

The Digital Print: A Complete Guide to Processes, Identification and Preservation

Martin C. Jurgens (Thames and Hudson) 2009 ISBN: 9780500514986

Guide to Preventive Conservation of Photographic Collections

L. Bertrand (Getty) 2003 ISBN: 0892367016

Issues in the Conservation of Photographs

Edited by D. Norris (Getty Conservation Institute) 2010 ISBN: 9781606060001

Photographs of the Past: Process and Preservation

B. Lavedrine (Getty Conservation Institute) 2009 ISBN: 9780892369577

PRESERVATION OF ARCHIVAL MATERIAL

Limp Vellum Binding

by Christopher Clarkson

The Broad Spectrum: Studies in the Materials, Techniques and Conservation of Color on Paper

Edited by H. Stratis and B. Salvesen (Archetype) 2002 ISBN: 1873132573

Conservation Mounting for Prints and Drawings

J. Kosek (Archetype) 2004 ISBN: 187313259X

Printed on Paper: The Techniques, History and Conservation of Printed Media

Edited by J. Colbourne and R. Snyder (Northumbria University) 2009 ISBN: 9780956120632

Retouching of Art on Paper

T.G. Poulsson (Archetype) 2008 ISBN: 9781904982135

The Restoration of Engravings, Drawings, Books and Other Works on Paper

M. Schweidler (Getty) 2006 ISBN: 089236835

DVD: Book Restoration using Cloth Rebacking

by Deborah Evetts

CONSERVATION TREATMENTS

Conservation Treatment Methodology

B. Applebaum (Butterworth) 2007 ISBN: 0750682744

DISASTER RECOVERY

Theory and Practice in the Conservation of Modern and Contemporary Art

Edited by Ursula Schadler-Saub and Angela Weyer ISBN: 9781904982548

Italian Renaissance Drawings: Examination and Analysis

Edited by Janet Ambers, Catherine Higgitt and David Saunders ISBN: 9781904982586

Early Metal Mining and Metallurgy

by Paul Craddock
 ISBN: 9781904982593

ANOXIC STORAGE AND PEST ERADICATION

Pest Management in Museums, Archives and Historic Houses

D. Pinniger (Archetype) 2001 ISBN: 1873132867

Pollutants in the Museum Environment: Practical Strategies for Problem Solving in Design, Exhibition and Storage

P. Hatchfield (Archetype) 2002 ISBN: 1873132964

STORAGE GUIDELINES AND CONSERVATION FRAMING

Historic Framing of Watercolours, Drawing and Prints

Bell (IPC) 1997 ISBN: 0950726877



Storage and Workshop Furniture



Storage and Workshop Furniture

- Drawer Storage
- Picture and Roll Storage
- Museum Cabinets
- Studio Furniture

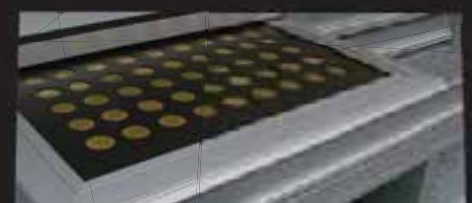

Storage and Workshop Furniture

Since 1992 Conservation By Design Limited (CXD) have been supplying well-designed, high-quality storage, workshop and display furniture to the conservation marketplace. Some items such as the Planorama® Aluminium Drawer Storage System are made in our Bedford factory and others are made by selected partners chosen for their specific expertise.

The product portfolio contains a variety of standard and bespoke storage cabinets, which will suit most applications, in addition to specialist museum cabinets, picture-racking and mobile storage systems.

Conservation furniture should be manufactured from safe, non-reactive materials such as powder-coated steel, stainless steel or anodised aluminium, as they may be required to store anything from coins to flags or even dinosaur bones, all of which may have special requirements for their preservation. CXD take pride in providing solutions for the most difficult of storage problems.

In this catalogue some standard products are listed in popular sizes but CXD often work in partnership with clients to produce custom solutions for their needs.

Planorama® Drawers



At the top of the range is the Planorama® system, first delivered to the Utrecht State Record Office in 1970 and acknowledged as being a revolutionary advance in archival storage. Since 2000 these units have been manufactured at CXD's Bedford factory.

Lightweight and space-efficient, they are formed exclusively from conservation-grade materials, including unique aluminium profiles from which drawers can be produced as thin as 10mm for coins or large enough to store ships' flags up to 5 metres wide.

Drawer options

- Drawers can be supplied with a choice of inert, lightweight and rigid bases. The patented, drummed polyester bases are the lightest available and most suitable for shallow drawers and the maximum separation of documents
- The standard drawer depths are 10mm, 20mm, 42mm, 64mm, 86mm and 108mm. In addition, deeper drawers can be customised as required, based on 11mm increments. The drawer fronts feature a full-width handle with integral label-holder. Every new order of cabinets is delivered with a digital label-maker with labels designed to fit the label-holder (F)
- Planorama® has removable drawers of different depths which are interchangeable because of the low-maintenance slides which are set at 11mm increments. Where very heavyweight storage is required, high-quality, telescopic drawer slides may be fitted (B)
- Cabinets can be supplied with glass tops so that the top drawer acts as a display cabinet. Deeper drawers with glass, Optium® acrylic or polycarbonate tops are ideal for open-access display (C) See page 245
- Drawers can be removed and displayed vertically in a Frameorama™ display unit. See page 246.



D



A



B



E



C



F

- Cabinets with solid or transparent doors combining drawers and shelves are possible using this system (A)
- For aesthetic purposes drawer fronts of other styles, including wood, are available
- Special features such as custom-made enclosures for coins, drawer dividers made from aluminium or Plastazote® and securing devices for documents and wax seals can be fitted within the drawers (D and E)
- The lightweight, removable drawers are extremely useful in the event of an emergency
- Where required, the drawers can be fitted with a unique, pull-out locking system to prevent them being removed without the use of a special device
- Drawer depths can be mixed in a single module as required. To ensure a dust-free environment the cabinet modules and the front of each drawer is fitted with dust-exclusion brushes.



Modular

The standard module heights are 240mm, 416mm, 592mm, 768mm, 944mm, 1120mm, 1296mm but, because Planorama® is a bespoke product, other heights can be provided.

- Modules can be stacked on top of each other using a secure fixing profile
- Plinths or support frames can be made to specified heights and can be fitted with removable cleaning and access plates
- The modules or plinths are supplied with solid aluminium and stainless steel levelling feet.

Security

- For safety, to prevent the cabinet tipping, deeper drawers can be fitted with an anti-tilt mechanism so that only one drawer can be opened at a time
- Cabinets are secured with an Abloy® central-locking system
- The cabinets can be fitted with stylish castors or heavy-duty locking wheels.

If it can be imagined it can probably be made.



Whitworth Art Gallery Planorama® showing a combination of deep and shallow drawers



Planorama® drawers and cabinet

London Print Studio showing glass display top



Selected Customer References: The Royal Collection Trust, The British Museum, Tate Britain, National Museums Scotland, National Library of Wales, National Army Museum, Imperial War Museum, The Science Museum, Fitzwilliam Museum, The Wellcome Trust, The Louvre, Musée Rodin and The Alhambra Archives.

Bespoke

The standard colour and finish is matt silver, anodised aluminium.

On special request a variety of colours can be achieved by anodising or polyester powder-coating (G).

Planorama® aluminium furniture is approximately one third of the weight of steel cabinets. Planorama® has been selected for buildings with inadequate floor loadings.

Where it is difficult to supply an assembled cabinet, Planorama® can be delivered flat in component form and assembled by our technicians on-site.

The Planorama® design and sales department will provide a detailed quotation including packing, transportation, insurance and installation costs.

More than forty years of installation experience gives us the confidence to deliver to most locations.



Imperial War Museum, London. Planorama® Drawers and Armour CXD showcases.

Drawer Storage

CXD Sterling SMD Plan Drawer Range

Smart Metal Design, proven designs custom-made to order.

The Sterling SMD range of drawers features a variety of tried and tested designs that have been developed and supplied to archives and libraries throughout the United Kingdom. The latest CNC technology allows custom-made variations of size to be produced at very competitive prices.

All cabinets are manufactured from heavy-duty, powder-coated steel and colours can be specified using the BS or RAL colour systems and feature a choice of roller bearings or telescopic drawer-slides.

They come with angled or flat fronts with recessed, full-width handles or can be fitted with conventional 'U' type handles. Unless otherwise requested, the drawers are fitted with hinged flaps and rear cover-plates to prevent curl of maps and drawings.

Drawer depths can be specified as required, however the classic angled-front design with shallow 33mm drawers has proven very popular with the larger map libraries.

In addition to the fixed front drawers a drop-front design has been developed to ease the removal of files. This is especially helpful for higher-level drawers in stacked cabinets.

Penny Hughes, National Portrait Gallery:

"We chose to work with CXD because they offered the Gallery the best value both technically and commercially. The furniture solutions provided will bring our on-site storage facilities up to the highest standards for long-term preservation and access as well as relieving current pressure points and creating sufficient space for the growth of the collection held on-site for the foreseeable future."

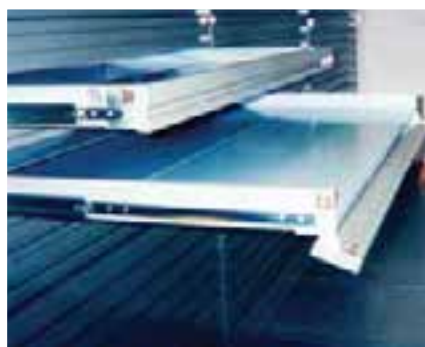

SMD drop-front, oversized drawers. The special base design utilised for the drop-front drawers facilitates bigger-sized cabinets.



SMD Easy Loader roller shelves. These unique shelves feature smooth-running rollers fitted to the front to aid the loading and unloading of heavy storage boxes.

CXD Euro 'KD40' Plan Drawer Range

These stylish and well-designed, powder-coated steel drawers are designed for flat graphic works and are available in A1 and AO+ sizes which will take an AO CXD Visifile™ folder. Both sizes of cabinet are available in 4-drawer-height combinations each running on smooth-action roller bearings with drawer loadings up to 40kg. The drawers can be sub-divided into A format sizes using optional drawer dividers. These fit into pre-punched slots in the drawer-base. There is a retaining clamp at the front and fold-over panel to the rear of each drawer to prevent papers being pushed over the back edge. KD40 drawers feature two label-holders, central handle, a secure central-locking and an anti-tilt system, which only allows a single drawer to be opened at a time. They come with a choice of a closed steel plinth or an open-sided, steel base-frame. To finish the cabinets, plastic-faced worktops are available. If required units of the same size are stackable.

The standard colour throughout the CXD Euro range is Light Grey; RAL 7035. Also available is the stylish Pearl White; RAL 1013, which is popular with designers. Please note that there is an increased delivery time for this colour.



Product code	Description
EQHADCS063	Worktop – A1
EQHADCS060	5 x 65 external height drawers – A1
EQHADCS0640	5 x 130 external height drawers – A1
EQHADCS065	8 x 65 and 1 x 130 external height drawers – A1
EQHADCS061	10 x 65 external height drawers – A1
EQHADCS064	Plinth – A1
EQHADCS073	Worktop – AO
EQHADCS070	5 x 65 external height drawers – AO
EQHADCS0740	5 x 130 external height drawers – AO
EQHADCS075	8 x 65 and 1 x 130 external height drawers – AO
EQHADCS071	10 x 65 external height drawers – AO
EQHADCS074	Plinth – AO



SMD sloping-front drawers on full extension, telescopic drawer-slides with Solander box-storage shelves.

Euro Pro High Capacity

Unit of 3 drawers with an effective height of 165mm. 30kg effective load per drawer. Drawers feature chrome-plated handles, label-holder and security lock.

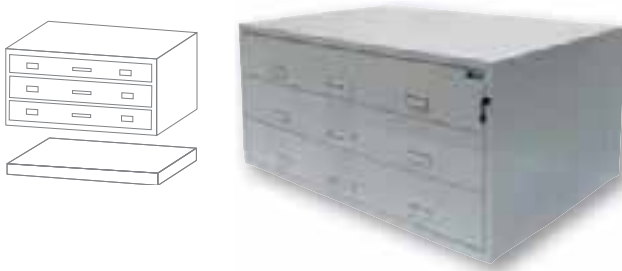

Product code	Description
FUSTFS0032	Filing cabinet 3 big drawers size – with top Ext. dimensions: D96.5 x W140 x H66cm Int. dimensions: D92 x W130 x H16.5cm
FUSTFS0033	Single base in epoxy-painted steel for FUSTFS0032 – H10cm

Euro Pro Continuous Handle

With the full range of Euro Pro options available, this range of A0 cabinets offers great flexibility, from the 8-drawer cabinet with 30mm-height drawers to the 30-drawer cabinet with 26mm-height drawers.

A great selection of units catering for moderate to high-density, high-quality storage of flat documents, artworks and small objects or specimens.



Product code	Description
FUSTFS0019	Filing cabinet 8 drawers A0 size – without top Ext. dimensions: D96.5 x W140 x H42cm Int. dimensions: D92 x W130 x H3cm
FUSTFS0020	Top for MAL8S – H3cm
FUSTFS0021	Base for MAL8S – H10cm
FUSTFS0022	4-leg base in epoxy-painted steel
FUSTFS0023	Filing cabinet 10 drawers A0 size – without top Ext. dimensions: D98.5 x W141 x H50cm Int. dimensions: D93.5 x W131 x H3cm
FUSTFS0024	Filing cabinet 20 drawers A0 size – without top Ext. dimensions: D98.5 x W141 x H100cm Int. dimensions: D93.5 x W131 x H3cm
FUSTFS0025	Filing cabinet 30 drawers A0 size – without top Ext. dimensions: D98.5 x W141 x H150cm Int. dimensions: D93.5 x W131 x H3cm
FUSTFS0026	Top for MAL10S/MAL20S/MAL30S – H3cm
FUSTFS0027	Base for MAL10S/MAL20S/MAL30S – H10cm
FUSTFS0022	4-leg base in epoxy-painted steel

Euro Pro Classique

Horizontal plan chests with 5 drawers in epoxy-painted steel with continuous handles, chromed label-holders and safety lock. Stackable units with optional stand.

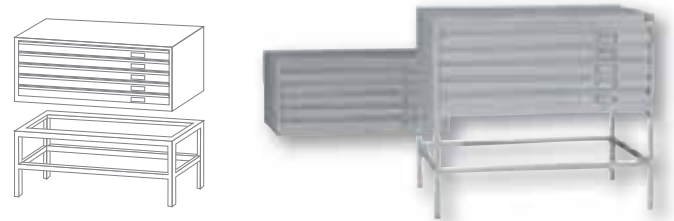

Product code	Description
FUSTFS0028	Classic filing cabinet 5 drawers A0 size – without top Ext. dimensions: D96.5 x W140 x H42cm Int. dimensions: D92 x W130 x H5.5cm
FUSTFS0022	4-leg base in epoxy-painted steel

Roll Storage

Stackable units of 24 (60mm x 40mm) or 54 (90mm x 60mm) compartments made of epoxy-painted steel box section, with optional 4-leg base.



Product code	Description
FUSTRS0024	Stackable units of 24 compartments
FUSTRS0054	Stackable units of 54 compartments
FUSTRS0175	Option 4-leg base

Mobile Compact Shelving

Mobile storage offers a high-density storage for small and large repositories. A wide range of shelving is available that sits on superbly engineered mobile bases.

The CXD Projects Department can supply mobile shelving. Alternatively we are happy to liaise with a customer's preferred provider of compact shelving, when supplying one of our drawer systems.



Picture and Roll Storage

Crystallizations Systems Inc. (CSI) Convertible Lightweight Aluminium Picture Storage System

The relocation of permanent collections has become such a frequent event that most museums include contingencies as part of the planning process. In response to this important consideration, CSI developed the Convertible Storage System. It provides unparalleled flexibility for your collections today and into the future.

The new system boasts an ultra-flexible design that enables fast, trouble-free conversion from a ceiling-supported installation to a floor-supported installation... or vice versa, as space requirements demand. Fully reusable, the time, space and energy-saving CSI Convertible helps to stretch museum-operating budgets.

The CSI Convertible storage unit is constructed of conservation-safe, lightweight aluminium. It requires no modification to convert. Only movement and guidance hardware are exchanged. Aisles are always track-free. Safety and protection for the collection and museum staff is never compromised, and the floor space is clear. And, since structural integrity is built in, the Convertible Storage System is completely safe. Investment in a CSI Convertible Storage System offers long-term cost-savings.

CSI's full line of installation options include: New Convertible, Floor-Supported, Ceiling-Supported, Wall-Mounted, Free-Standing and Topless.



Museum Cabinets

Museum Herbarium and Entomology Cabinets

Cabinets are manufactured from fully welded, heavy-duty, powder-coated steel and colours can be specified using the BS or RAL colour systems. If required, the cabinets can be fabricated from stainless steel. All fixing holes are sealed against ingress of museum beetle and doors are fitted with inert Plastazote® gaskets. They can be supplied with single or double doors, and fitted with shelves or trays. Shown here are examples of custom-made cabinets designed to meet the needs of large institutional customers.



Open Cabinet with insect display



Entomology Cabinet with wooden drawers



Open Herbarium Cabinet

Studio Furniture

The CXD Studio Furniture System

This range of furniture has been designed especially for graphic arts and conservation studios. It consists of fixed and height-adjustable worktables, light-tables, storage drawers and cabinets. They are made from heavy-gauge, powder-coated steel and have worktops normally made from Trespa® which is a hard-working laboratory-rated material that is durable and easy to clean. Other surfaces such as Corian® or Hardwood can be specified if preferred. The standard CXD Studio cabinets come in a variety of widths and depths which can be specified with drawers, shelves or a mixture of both. If required, the drawers can have locks and anti-tilt mechanisms. Cabinets can have wheels if required and can be fitted beneath the standard-height Studio Worktables.



Sharon Connell the Conservator at the University of Leeds Brotherton Library says:

"We had our studio kitted out with furniture supplied by CXD - including desks, storage drawers, shelving and a light table - in 1995. It has endured very well indeed thanks to the excellent build quality and still looks stylish and almost as good as new"



Customer references include: University of Leeds Brotherton Library, National Galleries of Scotland, University of Manchester John Ryland's Library, Newcastle University Library, The British Library, The National Library of Ireland (Dublin), The Chester Beatty Library (Dublin), The British Postal Heritage Museum and Archive, The Wellcome Trust.

Studio Range – Worktables, Fixed and Height-Adjustable

Standard worktables are available in widths of 700mm to 2400mm, depths of 700mm to 1200mm and heights of 800, 900 and 1000mm.

To meet the needs of conservators, bespoke worktables are available with options of size, weight-loading and height-adjustability. They are offered as standard with laboratory-rated Trespa®, which is resistant to most chemicals used in conservation treatments.

Available in sizes up to 3 x 2m with a choice of fixed, manually or electronically adjustable height so that users can alter the table to suit their natural working position and ensure that delicate treatments can be done with the utmost care. The manually adjustable tables are positioned by means of a rotary handle, whereas the electronic version can be adjusted either by a small button mounted on the table or by remote control.

These tables are suitable for evenly distributed weight-loading of up to 130kg, with the option of increasing the loading to 250kg.

Within these units, CXD are able to offer a range of bespoke options such as inset light boxes using fluorescent tubes, LED lights or CeeLite® Imm light sheets to make the maximum use of your table surface.

A demonstration model with remote control is available to view on request, please contact CXD for further information.



- Durable powder-coat finish
- Designed for studio use



- Drawer dividers
- Drawer unit to fit beneath bench



CXD Studio 'VX 200' Heavy-Load Drawer Range

The VX Drawer range stands apart from other steel plan chests offering larger sizes and 200kg drawer-loading with no sagging. The exceptional weight-loading of these drawers was originally developed for holding large and heavy archival boxboard or mounting board. Standing on telescopic legs, the working height is adjustable between 800 and 1000mm. The drawer runners operate smoothly on heavy-duty roller ball bearings for ease of opening and closing, even with a heavy loading. Studio VX units come with 9 drawers, each with a 50mm internal height.

There are 9 sizes ranging from VX01 with outside dimensions of width 860 x depth 630mm to VX09 width 1960 x depth 1430mm.



Studio Range – Drawer and Shelf Cabinets

Studio drawer and shelf cabinets are divided into 15 parts, allowing shelves or drawers of various heights to be incorporated into a single cabinet. They are available in widths of 700, 800, 900 and 1000mm and depths of 700, 800, 900, 1000 and 1100mm and heights of 550 to 1000mm to either sit flush with or underneath the range of complementary Studio Worktables. Cabinets can be fitted with wheels and locks, if required.

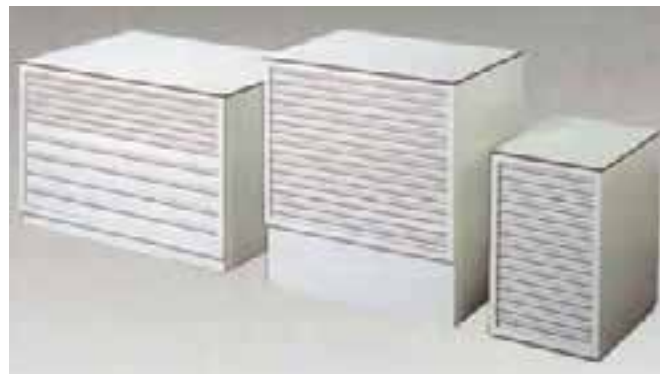

Studio Range – Shelf Cabinets with Doors

Studio shelf cabinets with doors are supplied with one shelf, which can be fitted into any one of the 15 pre-punched divisions. Extra shelves can be ordered. They are available in widths of 500, 600, 700, 900 and 1200mm and depths of 700 and 900mm and heights of 550 to 1000mm to either sit flush with or beneath the range of complementary Studio Worktables. Cabinets can be fitted with wheels, if required.



Museum Showcases



Museum Showcases

- Bespoke Museum Showcases
- Glass-Top and Display Furniture
- High-Security Cabinets
- Display Frames

**ARMOUR
SYSTEMS**



**CONSERVATION
BY DESIGN**
A Larson-Juhl Company

Museum Showcases



CXD Museum Showcases

Since first offering conservation-grade showcases in the UK and Irish markets in 1995, Conservation By Design Limited (CXD) have completed a large number of prestigious projects, most notably in recent times supplying The William Morris Gallery, which was named Museum of the Year 2013 by the Art Fund.

In 2013 CXD acquired Armour Systems. Combining the strengths of both companies, the partnership marks an important strategic step in CXD's development plans. This has enabled us to offer the qualities you expect; a bespoke, high-quality, museum-grade range of glass options and manufactured in the UK, for those needing 1 or 100 showcases. The companies have worked closely and effectively in the past; a great example of which is the very successful installation at the Imperial War Museum (see image on this page) where CXD provided the Planorama® drawers and Armour CXD museum showcases.



Relying on our in-house experience and expertise from design through to installation, allows for truly bespoke solutions to be offered with an 'anything is possible' attitude from the ground up. To achieve this many of the components are also custom-made in-house. The same meticulous craftsmen who build your showcases in our factory are those who come to you and install them. This gives our skilled engineers an almost tangible sense of ownership, which can only be seen once the elegant display cases are installed.

These combined factors of materials and people allow us to take full control and ownership for supplying precisely what is desired and required.

For those looking to specify showcases, please see our website for inspiration from previous installations and our Designers and Specifiers PDF guide,

www.cxdltd.com/showcases or www.armoursystems.co.uk.



Imperial War Museum, London

Bespoke Museum Showcases



Ashmolean Museum, Stradivarius Exhibition, Oxford



Vindolanda, Northumberland



Robert Burns Birthplace Museum, South Ayrshire



WW2 Valor in the Pacific, Honolulu



M Shed, Bristol



National Waterfront Museum, Swansea



William Morris Gallery, London



Conoco Phillips, Oklahoma

Glass-Top and Display Furniture

CXD Glass-Top Display Drawers



CXD custom-made, glass-top display drawers are typically manufactured from steel with a durable, powder-coated finish. Drawers can be finished with wooden fronts and liners made from Zero Formaldehyde (ZF) MDF with Baumann cloth coverings, Activated Charcoal Cloth® or Plastazote®, which can be routed-out to securely house delicate objects.

Each of these display drawers is bespoke and made to fulfil the concept of the designer or client.

For Open Access and Reserve Collections



There has been a growing demand for making collections more accessible and CXD have responded to this with a wide range of product solutions, ranging from secure visible storage drawers to reserve collection showcases. The criteria for reserve collection storage can be very different from normal gallery display. For example, visible storage of reserve collections needs to store as well as display and will contain many more objects. Delicate museum objects in public-access drawers need to be cushioned against vibration caused by careless opening and closing of the drawers. Access to the contents of the drawers should be difficult for the public but easy for the curator. Reserve collection showcases should be solid, functional and sealed to the required conservation standard against dust and humidity.

CXD Planorama® Glass-Top Cabinet and Display Drawers



Planorama® anodised aluminium drawer cabinets can be converted by the addition of a special profile designed to allow the top drawer of a cabinet to be used as a showcase. This unique profile is known as Frameorama™; it was designed to accommodate laminated glass or plastic up to a thickness of 11.5mm for high-security display. It is a stylish profile which can be transformed by the addition of insert plates of different colours or finishes.

Planorama® drawers can be covered in various ways with glass, polycarbonate or acrylic including Tru Vue®, Optium® Museum which is lightweight, non-reflective, UV-blocking quality and scratch-resistant. The drawers can be lined or supplied with a variety of fittings to secure the objects displayed.

 [Linked Products: Details of the Planorama® Drawer System are on p66, 172, 233, and 245.](#)

CXD Electronically-Operated, Push-Button, High-Security Drawer Cabinets



The electronically-operated conservation display drawer cabinets are smooth-fronted, without handles so they cannot be opened or closed too quickly or forcibly by those who may not know or appreciate the delicate nature of their contents. The drawers' electronic regulator ensures opening starts and stops slowly so that the enclosed objects are protected against shock or vibration. The guided opening and closing mechanism prevents lateral vibration.

They are designed so that only one drawer can be opened at a time.

High-Security Cabinets

CXD Discovery High-Security Drawer Cabinets

These unique conservation display drawer cabinets will give you complete peace of mind over your displayed collection – with easy accessibility for visitors whilst providing high-level security protection.

The CXD Discovery unit is manufactured in steel with a durable powder-coated finish. Each cabinet is designed with drawer-frames which are loaded with a removable base-tray and secure glass cover enabling the contents of the cabinet to be quickly and easily changed. Additional display-trays can be supplied, allowing a new display to be prepared remotely, ready to be loaded into the drawer-frames for the next exhibition.

Specification

- Built from steel with a powder-coated finish to colour-coordinate with surrounding décor
- Central-locking of complete cabinet using Abloy® high-security locks
- Each drawer-frame accommodates a removable and interchangeable smooth base-display-tray
- Removable laminated glass drawer-cover with two discreet Abloy® locks
- When drawers are fully opened, 100% of the display area is visible
- Silicone gasket for controlled air exchange for each drawer
- Internal base-display-tray construction is resistant to water ingress from above
- Robust anti-tilt drawer mechanism – allowing only one drawer to be opened at a time
- High-quality drawer-slides with security system to prevent unauthorised removal of drawers from cabinet
- Fully accessible for display-tray-loading, unloading, cleaning and maintenance

Options

- Handles – different styles, materials and colours
- Drawer fronts – steel, wood, MDF etc.
- Variety of label-holders
- Locking – different levels of key security available
- Limit switch-mounting for internal display lighting
- Bespoke build – sizes to your specifications

Bespoke drawer-liners and inserts made to order using in-house CAD cutting service

- Plastazote®
- Charcoal Matting™
- Corrosion Intercept® foam
- Timecare® Museum mountboard

National Museums Liverpool Clore Natural History Centre



Display Frames

CXD Frameorama™ Display Frame

The Frameorama™ profile originally designed to fit on top of a cabinet can also be used vertically as a wall frame and has been used as the foundation for a number of custom-made display furniture solutions including climate-controlled display frames and high-security showcases.



Items secured in a Planorama® drawer can be transferred from a cabinet directly to the Frameorama™ display frame, reducing handling and risk to the object.

Oxygen-Free Showcase

A small oxygen-free showcase made by Armour/Conservation By Design for the storage and display of a precious meteorite.



Glossary of terms

Accelerated Ageing Test - A technique to estimate the permanence of paper by exposing it to simulated conditions of heat, moisture and/or chemicals.

Acid-Free - Paper free from any acid content or other substances likely to have a detrimental effect on the paper.

Activated Charcoal (Activated Carbon) - Carbon that has been treated with high-temperature steam to produce a porous structure; it is an excellent absorbent.

Air-dried - Term applied to paper which is dried by hot or cold air. Can include machine drying (hot air) or loft drying.

Alkaline Reserve - A paper additive such as calcium carbonate that serves to counteract the deleterious effects of the paper's own natural degradation, acidic inks and any other acidic components in the environment that may contact the finished sheet of paper. Also commonly called 'buffer'.

Alpha Cellulose - (see Cellulose)

Alum - Aluminium sulphate, added to gelatine in the sizing of paper to stabilise the gelatine. Also, a papermaking chemical used for precipitating rosin size onto pulp fibres to impart water-resistant properties to the paper. It is also known as papermaker's alum or hydrated Aluminium Sulphate ($Al_2(SO_4)_3$). It is highly acidic and will damage the paper if not removed.

Aqueous - Of, like, or containing water; watery.

Archival Paper - Permanent, durable and acid-free paper, which will not deteriorate over time. A paper with excellent long-life qualities, lignin and sulphur-free, with good colour-fastness.

Beater or Hollander - Hand or mechanical maceration of fibres to prepare them for pulp.

Bleed/Bleeding - Migration of colour in water or other solvent. Diffusion or dispersion of the colourants used for boxboard/mountboard.

Blue Wool Scale - Light-fastness is measured by the Blue Wool Scale.

Buffering - The acid neutralisation in paper by adding an alkaline substance (usually calcium carbonate or magnesium carbonate) into the paper pulp. The buffer acts as a protection from the acid in the paper or from pollution in the environment. (see Alkaline Reserve.)

Calcium Carbonate - A type of loading agent used in papermaking as filler.

Calendering - Process of pressing to smooth or glaze a sheet of paper during the finishing process.

Calliper - The thickness of a single sheet of paper measured in microns (10^{-3} mm).

Cellulose - The main constituent of the cell wall of all plants. All plants will yield cellulose if properly processed. Cotton in its raw state is the purest form of natural cellulose. Cellulose is the basic substance of paper manufacture.

Chemical Wood Pulp - Wood reduced to pulp by a chemical process, e.g., with caustic soda or bi-sulphite of lime.

Colour-fast - A term to indicate resistance to fading or washing out.

Cotton - Source of fibre for papermaking, usually in the form of linters or rags. The fibres are strong and flexible and suited to the production of fine papers. (see Cellulose.)

Couch - Action of transferring sheets of newly formed paper

Crash Lock - A box designed so that the base locks in place when pressed from opposite corners, without the need of adhesive or fixings.

Deckle edge - Slightly wavy line to the edge of handmade paper. This is formed by a slight thinning of the edge of the sheet by pulp creeping under the edge of the deckle during making.

Die-cutting - Is the manufacturing process used to make multiples of the same box or folder from a cutting tool.

Dimensional Stability - Paper or board may change in its dimension and flatness with variations in its moisture content. It is termed dimensionally stable when such changes are of a low order.

Dry Mount - Is used for temporary or permanently adhering prints/documents to a more rigid backing such as mountboard or foam board.

Drying loft - Large airy room in which sheets of handmade paper are hung or laid to dry.

Duplex - Usually made by laminating two sheets of paper together. Each side is different; this may be a different colour on each side or a different finish or different textures.

EVA (Ethylene Vinyl Acetate) - Neutral pH, non-plasticised, reversible archival paper laminating adhesive. It is less susceptible to acid hydrolysis than conventional PVA adhesives.

FATG - Fine Art Trade Guild (www.fineart.co.uk)

Fascicule - A conservation term referring to a gathering of leaves of paper, with a stiffener paper covering, sewn through the spine.

Filler - Material added to the beating stage to fill in the pores of the fibre, producing a harder surface.

Freeze-drying - A process by which material is dried from the frozen state by use of high vacuum. Also see Vacuum-drying.

Furnish - The ingredients in the beater, which when added together, give a specific type of paper.

Gampi - A bast fibre from the "Gampi" tree used in Japanese paper making to yield a smooth, strong sheet.

Gelatine - A type of size obtained from animal tissues applied to the surface of paper to make it impervious to water and to aid resistance to bleeding during printing. Also imparts surface strength to watercolour and drawing papers.

Grain (Direction) - Alignment of fibres in a sheet of paper caused by the flow of the web of wet paper in Cylinder or Fourdrinier machines.

Grammage - Metric system of weight (in grams) per square metre (gsm) of paper or paperboard.

HEPA (High Efficiency Particulate Air) - A filter capable of retaining 99.97% of all particles down to 0.3 microns.

Hemp - One of the oldest fibres recorded in use in papermaking, the fibres are strong and inclined to split in the beating process.

Hot pressed (HP) - One of three traditional finishes of handmade paper. Originally produced by pressing the paper between hot metal plates, later by plate-glazing.

Hydration - Process of take up of water by the fibres through crushing and fibrillation during beating.

Humidity - The moisture condition of the air. Relative Humidity (RH) is the percent of moisture relative to the maximum which air, at any given temperature, can retain without precipitation.

Inert - Not readily reactive with other elements; forming few or no chemical compounds.

Internal-sizing - Sizing which is added to the pulp during the making process. (see Sizing)

Kappa Number - A test for the degree of lignification of pulps. Specifically, the number of millilitres of tenth-normal potassium permanganate solution consumed per gram of moisture-free pulp under standardised conditions.

Kozo - Several species of the paper mulberry used in papermaking. The fibres are long and sinewy.

Laid Papers - Those which, when held up to the light, have a ribbed or lined effect due to the paper being produced on a mould made with a cover of closely placed parallel laid wires to form the sieve through which the water drains.

Lamination - Two or more sheets of paper couched together directly on top of one another.

Lignin - A component of the cell wall of plants that occurs naturally. Can contribute to chemical degradation later in the life of the paper.

Linters - Three grades of cotton fibres obtained from the cotton plant after the ginning operation and used in papermaking; first cut or lint, mill cut and second cut. The fibres are short and do not need much refining.

Lux - Unit of illumination equal to the direct illumination on a surface.

Light-fast - Light-fastness, or colour-fastness to light, is the resistance of printed or pigmented materials to fading or colour change due to exposure to sunlight or an artificial light source.

Methylcellulose - A pure adhesive which dries clear. Suitable for archival use.

Micron - (Micrometre/Micrometer) 10^{-3} of a millimetre. Unit of length conventionally used to indicate board calliper.

Mitsumata - Plant used as a source of papermaking fibre, the fibres are fine and relatively short.

Mould - Rectangular wooden frame covered with either a laid or wove wire surface used for forming sheets of paper by hand.

OBA (Optical Brightening Agents) - Fluorescent dyes added to paper to enhance the brightness. Fluorescent dyes absorb ultraviolet light and re-emit it in the visual spectrum.

Opacity - Quality of a paper related to the amount of light that can be transmitted through its surface.

Parchment - Animal skins or linings stretched and prepared as a writing, painting surface.

PAT - The Photographic Activity Test, or PAT, is an international standard test (ISO18916) for evaluating photo-storage and display products by way of accelerated ageing tests.

PET - Polyethylene Terephthalate a linear polyester

pH - A measure of acidity, neutrality or alkalinity of materials such as paper and printing inks. On a scale of 0 to 14, a pH of 7 is neutral. Acids have a pH value below 7 while alkalis have a pH value above 7 (up to 14).

Phase Box - A conservation term referring to a box designed to give protection to a book.

Plasticiser - An additive that can add flexibility, softness and adhesion. In some materials plasticisers leach out in time and leave the material more rigid and liable to crack and go yellow.

Ply - A single layer of paper. A term used when several sheets of paper are laminated together to form a board.

Pocket - An enclosure welded on two or three sides.

Pulp - The aqueous mix containing disintegrated cellulose fibre from which paper is made.

PVA (Polyvinyl Acetate) - A white glue, transparent and partially water-soluble. Mixed with gel it can become water-resistant. There are many PVA adhesives, some are internally plasticised. (see EVA.)

PVC (Polyvinyl Chloride) - This chemical, which is present in certain types of plastic, can emit damaging hydrochloric acids as it degrades, causing damage to materials stored within.

Rags - Formerly the principal raw material for making paper, now rarely used except for very high-quality papers. Could be linen or cotton but by association also includes jute, sailcloth and hemp ropes.

Relative Humidity (RH) - The ratio of actual humidity to saturation at a given temperature. At a lower temperature, air can hold less moisture than at a higher temperature. Paper is safest in a range of 50-60% RH at a temperature of 16-18°C. Avoidance of significant RH fluctuation is one of the objectives of effective archival storage. Photographs require cooler, dryer conditions than paper.

Reserve - Sometimes used synonymously with 'buffer'. Alkaline.

Rosin - Used in the sizing of paper, usually used as a tub size, more likely to be used as an internal size. Detrimental to the permanence of paper.

Rough - Traditional paper finish, formed by the weave of the felts during the wet press.

Size/Sizing - The process by which gelatine, rosin, starch or other synthetic substances is added to paper to provide resistance to the absorption of moisture or inks. Can be applied by coating the finished sheet (surface-sized) or by addition to the pulp before forming (tub-sized).

Squelch Drying - Method of drying books and documents, developed by CXD using vacuum-packing technology.

Stamper - Hammers (often wooden) used to beat rags to pulp.

Stuff - Paper stock or pulp ready for making into paper.

Sulphur - Chemical inherent in some paper from manufacture, also present as sulphuric acid in atmospheric pollution.

TAPPI - Technical Association of Pulp and Paper Industry (www.tappi.org).

Texture - Surface of the sheet, can be altered at various stages of the paper making process.

Tub-sized - Sizing applied to hand made paper by soaking it in a solution of hot gelatine and alum after it has been formed, pressed, dried and allowed to cure. It then has to be pressed and dried again. Machine-made paper reels are passed through a tub of starch or gelatine before being dried by hot rollers.

Unbuffered - No alkaline filler.

UV Ultra Violet light - Radiation beyond the visible spectrum at the violet end, having a wavelength shorter than those of visible light.

Vacuum-drying - a conservation technique by which a book has excess water removed by vacuum-drying. (see Squelch Drying).

Wood-free - A shortened description of "Mechanical Wood-free". A printing or writing paper which is made from chemical pulp, and not from mechanical woodpulp.

Virgin Fibre (Primary Fibre) - Pulp used for papermaking/board making that has not previously been used in any paper or board product.

Zeolite - An inert crystalline aluminosilicate that has an affinity for specific molecules. Naturally occurring but often man-made to specific performance characteristics. Also called molecular sieves or traps.

Useful Conversion Factors

Inches to millimetres	x 25.4
Millimetres to inches	x 0.0394
Thousands of an inch to micron	x 25.4
Pounds to kilogrammes	x 0.4536
Kilogrammes to pounds	x 2.205
Imperial Tons to Metric tonnes	x 1.016
Metric Tonnes to Imperial tons	x 0.9842

Index

5000 DX Vocab – Room Air Cleaner.....	204	Bozone Gels.....	178	Folder - Four-Flap.....	55-61
5000 Exec UV – Archival Protection Systems.....	204	Brushes.....	124, 216-220	Folder - L-Shaped.....	47
Accessories and Tools.....	123-126	Byron Weston Resistall Paper.....	87	Folder - Map - Premier Duo™.....	60
Acrylic Solid Blocks.....	146	Cambridge Newspaper System.....	27	Folder - pHase 3™ Folder-Box.....	56
Activated Charcoal Cloth™.....	107	Cap - Polypropylene Head Protection.....	213	Folder - Photographic Print Four-Flap - pHoton™.....	66
Adhesive Laminated Paper Board.....	109	Capillary Matting.....	104	Folder - Photographic Storage.....	63-66
Adhesives, Pastes and Consolidants.....	127-131	Care Kits.....	209-210	Folder - Short-Flap, BT - Premier Duo™.....	61
Ageless® Eye Oxygen-Indicating Tablets.....	181	Carry Case with Handle.....	27	Folder - Single and Double-Crease.....	44-46
Ageless® Type ZPT.....	180	Cellulose Powder.....	102	Folder - Tryptich.....	45
Air Purifiers & Dust-Removal Materials.....	203-207	Channel Panel™ (Plastazote®).....	120	Folder - Western Manuscript String & Washer - Premier Duo™.....	61
Album Pages and Pockets - Timecare®.....	69-76	Charcoal Cloth®.....	107	Folders - Open-Topless Wallets/Pockets/Enclosures.....	48-51
Aluminium Vapour Barrier Complex.....	81, 107	Chemicals, Solvents and Cleaning Fluids.....	211	Folders, Envelopes and Pockets.....	42-62
Anti-Static Cleaning Kit - for glass only.....	207	Chemikit Paper Testing Kit.....	211	Folders, Envelopes and Pockets Styles.....	43
Anti-Static Cloth.....	207	Clarity by Larson Juhl, Waterwhite Anti-Reflective Glass.....	149	Framing Tables.....	132
AR Reflection-Free® Tru Vue® Glass.....	149	Clarkson Book Support System.....	143	Framorama™ Display Frame.....	246
Archibond™ - Unsupported.....	105	Clean Breeze III – Fume Source Capture.....	203	Fume Extraction Cabinet with Air Purifier.....	212
Archibond™ Tissue.....	105	Cleaning Materials.....	209-211, 216, 217	Gas-Barrier Film.....	79, 182
Archipress™ High-Barrier Vacuum Pouches.....	80	Cleaning Solution.....	212	Gatorfoam®.....	119
Archival Aids.....	211-212	Cleaning Swab Sticks.....	207	Glass and Acrylic - Clarity and Tru Vue®.....	149-150
Archival Cloth™ with Texicryl Adhesive.....	105	Cloth-Covered Boxes.....	14-21	Glass Plate Storage.....	23
Archival Rag Endleaf 100% Cotton.....	85	Cokon™.....	103	Glass Protection Tape.....	135
Archival Tapes.....	133, 136	Cold Storage.....	67, 230-231	Glass-Top and Display Furniture.....	245
Area Bonded Fibre.....	105	Conservac.....	200 - 201	Glossary of Terms.....	248
Artsorb®.....	189	Conservation Bookmate™ Companion Set.....	143	Gloves.....	215
Assembly Methods - Boxes.....	9	Conservators' Choice Artist Quality Watercolours.....	123	Goggles.....	214
Backing Boards and Support Boards.....	117-120	Corner Rounder.....	152	Goldfinger Metallic Paste.....	123
Bags - Storage and Transportation.....	79	Corrosion Intercept® Film and Bags.....	78, 106	Guillotine - Floor-Standing and Table-Top.....	155-160
Barrier Foils.....	81,107	Corrosion Protection and Barrier Materials.....	106-107	Handmade Cloth Covered Boxes.....	9
Bassaire Mobile Clean Air Conservation Work Station.....	205	Corrugated Boxboard.....	109-111, 117	Handmade Papers.....	90-93
Benzotriazole, Pure.....	211	Costume Bag.....	78	Hanging Bar.....	51
Beva 371.....	127	Cotton Linters - Machine-Made.....	102	Hanging Rods and Accessories.....	147
Big Yella Bag™ and Transfolio™ Bag.....	79	Criss Cross Heat-Sealing Machines & Accessories.....	173	Headsets (noise-cancelling).....	215
Blotting Papers.....	101-102	Crystal Polyester Pages, Pockets and Protectors.....	69-78	Heat Sealing Machines and Welding Machines.....	173-174
Blue Wool Scales/Fade Indicator Card.....	190	Cutting Equipment.....	151-161	Heated Lining Iron Tools & Accessories.....	164
Board - Archival Boxboard - Premier Duo™.....	110-111	Cutting Mats - Self Healing PVC.....	151	Herbarium Cabinet.....	238
Board - Corrugated/Fluted.....	109-111, 117	Dahlia Spray.....	164	Herbarium Mounting Cartridge 100% Cotton.....	86
Board - Handmade Bookbinders and Millboard.....	112	Dancheck Film Indicators.....	191	Heritage Acid-Free Blotting Paper.....	101
Board - Mounting Boards.....	113-116	Data-Logger.....	194-199	Heritage Archival pHotokraft™ (HAPK) Paper.....	84-85
Board - Premier Duo™ Bookshoe Boxboard - Solid Colour.....	110	Data-Logger, Dual-Channel.....	196	Heritage Archival pHotokraft™ Tape.....	132
Board - SolidCore Mountboard.....	113-116	De-acidification (AADA) Solution.....	212	Heritage Museum Edition - Timecare®.....	86
Board - Superior Millboard.....	112	De-acidification Solutions and Equipment.....	212	High-Security Cabinets.....	245-246
Board - Timecare® Heritage Mountboards.....	113-114	De-acidification Spray Unit DA06.....	212	Holytex® Acid-Free, Non-Woven 100% Polyester.....	104
Board - Unbuffered Conservation Board.....	114	Dehumidifier.....	188	Hot Air Gun.....	164
Board Creaser.....	176	Dehumidifier & Humidifiers.....	188-190	Hot Glass Vacuum Press (Lamination).....	171
Board Cutters.....	158-160	Delimer Water-Softening Device.....	165	Hot Knife.....	161
Board Range.....	108-109	Depulvera Mobile Workstation.....	205	How To Order.....	256
Boards - Support and Backing.....	117-120	Digital Book Measure - Kasemake CXD.....	176	Humidity and Temperature Measurement.....	192-199
Bondina®.....	103	Disaster Response, Recovery and Prevention Products.....	187	Humidity Control.....	188-190
Bone Folders.....	125	Discovery High-Security Drawers.....	246	Humidity Indicator Cards.....	190
Book Cleaning Machines.....	205	Display Frames.....	246	Infrared Thermometer – Laser Sighting and Integrated NTC Air Measurement.....	197
Book Measure Device - Digital and Manual.....	176	Display Risers.....	146	Insect & Pest Traps.....	177-178
Book Stand.....	145	Display Strips.....	137	Iron Gall Ink Test Paper.....	191
Book Stands.....	144 - 145	Drawer Storage.....	235-237	Japanese Brushes.....	218-220
Book Support Bags and Cushion Covers.....	144	Drum.....	146	Japanese Paper Collection.....	95-99
Book Supports and Displays - Wooden and Acrylic.....	143-146	Drying Rack - Planorama®.....	172	Kasemake.....	175-176
Bookbinders Linen Cord.....	131	Dual-Channel Temperature and Humidity Data-Logger.....	197	Kenair Air Duster.....	206
Bookmark Strip.....	77	Easy Loader, Roller Shelves.....	235	L'Aura Mobile Book Cleaner.....	206
Books & DVDs - Reference.....	231	EconoSpace®.....	148	Label-Holders.....	140
Botanic Storage.....	57	Enclosures, Pockets and Wallets, without Flaps.....	48-51	Labels - Self-Adhesive & Swing Tags.....	138-139
Box - Carousel Portfolio.....	15	Entomology Cabinet.....	239	Lamination.....	170-171
Box - CD/DVDs.....	19, 22-23, 25	Envelopes, Pocket & Wallets.....	52-67	Lanolin, Anhydrous.....	208
Box - Cloth-Covered Drop-Spine, PM & Portfolio.....	14-15	Environmental Monitoring Equipment.....	192-199	Lead Weights.....	144
Box - Cloth-Covered Portfolio and Ringbinder.....	17-21	Epoxy Disintegrator.....	211	Leather Dressing with Beeswax.....	208
Box - Drawer Tray.....	38	Erasers.....	209-210	Leather Dressing without Beeswax.....	208
Box - Drop Back Microfilm - Premier Duo™.....	13	Ethafoam®.....	119	Light Control.....	191
Box - Drop Spine - Tabbed.....	11	Euro Plan Drawer & Cabinets.....	235 - 237	Light Equipment.....	221-229
Box - Drop Spine - Tabless Box.....	13	Evacon-R™ - Adhesive.....	127	Lining Iron Tools & Accessories.....	164
Box - Drop-Wall.....	36	Extra-Fine Lightweight Cross-Peen Hammer.....	148	Logiciel.....	193
Box - Hinged-Lid.....	22-26	Fabiano Paper.....	87	Lost Head Nails.....	148
Box - Hinged-Lid with Carry Handle.....	27	Face Masks.....	213-214	Low-Barrier Bags.....	79
Box - Open-Top Vertical.....	39-40	Felt - Feutrex™ Polyester.....	104	Map/Banner Bag Calico.....	78
Box - Ringbinder.....	17-21	Flax Pulp - Machine-Made.....	102	Masks.....	213-214
Box - Solander Boxes.....	16	Foam (Plastazote®) Welding.....	120	Materials.....	103-105
Box - Storage Trays.....	39	Folder - Archival Flap - Premier Duo™.....	56	Matting.....	104
Box - Tube.....	40-41	Folder - Beaux Arts.....	60	Micofiche Storage.....	48
Box - Two-Part.....	28-35	Folder - Capsule.....	57	Micro-Mesh®.....	123
Box - Window.....	37	Folder - Clam/Self-Locking, Multi-Crease - Premier Duo™.....	56	Microballoons/Glass Balls.....	128
Box and Storage Products.....	7-41	Folder - Double Crease.....	45	Microfibre Cloth - Yellow.....	207
Box Styles.....	10	Folder - Envelopes - Archival Premier Duo™.....	55	Microfilm Boxes.....	13, 23
Box-Making - Kasemake CXD Smart Box™.....		Folder - Expanding Gusseted.....	55	Micrometer.....	154
Manufacturing Service.....	8	Folder - Expanding Gusseted Pocket - Premier Duo™.....	55		
Boxboard Range.....	7-10	Folder - Fluted Polypropylene.....	60		

Mini Light Meter – 540.....	199
Mini Pro V-300-HTK Conservation Vacuum Impulse Sealer.....	186
Mitsubishi Aluminium Foil Pouches.....	80
Mobile Dust Cleaner.....	204
Mobile Shelving.....	237
Moistop Barrier Foils.....	81, 107
Monitoring.....	192-199
Moulin du Verger Board.....	112
Moulin du Verger Papers.....	90 - 93
Mountboard.....	108-119
Mounting Strips - Corner, Display, V Mount.....	136-137
Multirestor®.....	166
Museum Cabinets.....	239
Museum Glass.....	149
Museum Showcases - Bespoke.....	244
Negatives Storage.....	50
Newspaper Storage.....	14
Nilfisk.....	202-203
Nylon Cord.....	148
Overall (with hood).....	213
Oxygen & Moisture-Barrier Bags and Films.....	79-81, 180
Oxygen Absorbing Scavengers.....	180-184
Oxygen Analysing Equipment (KnoOx™).....	180
Oxygen-Free Showcase.....	246
Oxygen-Free Storage.....	179-184
P Series Paper Pulper.....	166
Palettes and Saucer Sets.....	125
Palm Leaf Storage Box Wrapper.....	36
Paper - Acid-Free Paper - pHoton™, Timecare® & Archival.....	100
Paper - Acid-Free Tissue.....	100
Paper - Age Compatible Toned laid -Timecare®.....	87
Paper - Archival.....	84-86
Paper - Archival pHotokraft™.....	42, 44, 45
Paper - Blotting Range - pHoton™.....	101-102
Paper - Bookbinding and Mounting Papers.....	84-92
Paper - Byron Weston Resistall.....	87
Paper - Canaletto Liscio.....	87
Paper - Conservation - reference only.....	93
Paper - Cotton Rag Endleaf Archival Paper.....	85
Paper - Cover Papers.....	92
Paper - Fabriano - Copy Class 1 & Palatina.....	87
Paper - Flax Pulp - Machine-made.....	102
Paper - Glassine, Crystal.....	100
Paper - Griffen Mill (GM) range of papers.....	93-94
Paper - Hahnemuhle Cylinder Mould-Made Laid.....	87
Paper - Handmade European.....	90-94
Paper - Handmade Japanese.....	95-98
Paper - Herbarium Mounting Cartridge 100% Cotton.....	86
Paper - Heritage Acid-Free Blotting Paper.....	101
Paper - Heritage Archival pHotokraft™.....	84-85
Paper - Japanese Machine-made and Handmade.....	95-99
Paper - Medieval Dark Toned Laid.....	87
Paper - Megasorb™ - 100% Cotton Extra Heavy Blotter.....	101
Paper - Moulin du Verger Hand-made.....	91-93
Paper - Multisorb™ - 100% Cotton Highly Absorbent, Wet-Strength Blotter.....	101
Paper - pHoton™ Aqua-Forte - High Wet Strength.....	101
Paper - pHoton™ Bench Blot.....	102
Paper - pHoton™ High-Purity.....	42, 63, 64, 89
Paper - pHoton™ Roll.....	89
Paper - pHoton™ Sheets.....	89
Paper - Release.....	103
Paper - Tissue and Lightweight Range.....	99-100
Paper Clips, Brass and Polystyrene.....	140
Paper Pulper, E Series, P Series and S Series.....	166
Paper, Boards and Materials.....	83
Papermaking and Leafcasting Fibres.....	102
Paperweight - Heavy BeanBag™.....	124
Paperweight - Lead Weights.....	144
Parchment Release Paper.....	103
Pastes, Consolidants & Adhesives.....	127-131
Pens, Pencils and Inks.....	141-142
Pest & Insect Traps.....	177-178
pH Meter for Paper.....	198
Photography Lux and Colour.....	199
pHoton™ - About pHoton™.....	63
pHoton™ - Four-Flap Enclosures and Folders.....	64-65
pHoton™ Slitch in Timecare® Enclosures.....	50
pHoton™ Timelock™ Envelopes and Pockets.....	66
Pickwood Board Creaser.....	176
Picture and Roll Storage.....	238
Plan Chests.....	237, 240
Planorama® Aluminium Drawer Storage Systems.....	245
Planorama® Drawers.....	233
Plastazote®.....	120
Plate Display Cradle.....	146
Pockets, Wallets and Envelopes.....	48-61
Polish Wax and Dressings.....	208
Polyester - Album Pages.....	69-74
Polyester - Crystal Paperbacks.....	75
Polyester - Crystal Pockets.....	75-77
Polyester - Cut Sheets.....	78
Polyester - Display Strips.....	137
Polyester - Heat Seal Welding Equipment.....	173-174
Polyester - Mounting & Organising Accessories.....	136
Polyester - Oxygen and Moisture-Barrier Bags and Films.....	79-81
Polyester - Rolls Types 1 and 2.....	77
Polyester Edge Welder.....	174
Polyethylene - Washers.....	124
PolypHlute™ Corrugated Polypropylene + Polyethylene.....	111
Polypropylene - POLYNID™ Lightweight Honeycomb Board.....	119
Polypropylene CD Jewel Case.....	19
Portfolio - Premier Duo™.....	62
Pre-Lim Surface Cleaner.....	208-184
Premier Duo™ Archival Fluted Boxboard.....	111
Premier Duo™ Archival Folding Boxboard.....	110
Premier Duo™ Boxes.....	12-14
Premier Duo™ Folders.....	46-50
Premier™ 'Bookshoe' Boxboard - Solid Colour.....	110
PROSorb™ Humidity Control Systems.....	189
Psychrometer.....	197
PTFE Cloth.....	103
PTS-Grade, Very High-Barrier Pre-Formed Pouches.....	80
Pulvisina.....	206
Pure Linen Strapping and Welded D Rings.....	148
Purification Paint.....	101-102
Radio Probes & Routers.....	193
React Pack Disaster Kit.....	187
Reactive Intercept™ Barrier System (RIBS) Foil.....	80, 106
Record Sleeves.....	50
Reemay® Non-Woven Synthetic Fabric.....	104
Renaissance Metal De-Corroder.....	208
Renaissance Wax.....	208
Ringbinder Boxes.....	17-21
Riveting Machine and Matrices.....	123
Riveting Presses.....	176
Riveting Punch.....	123
Rivets.....	111, 124
Roll Dispenser For Rotary Trimmers.....	155
Roll Storage.....	238
Rolling Creaser, Portable.....	176
Rotary Trimmers.....	155
RP Oxygen-Absorbing Scavenger Agents - Types A and K.....	180
Scalpels/Knives.....	151
Sealants and Pastes.....	127-131
Semi Matic Laminator.....	170
Shelf Dummies.....	140
Showcases.....	243-246
Silicone Release Synthetic, Non-Woven and Heat-Set.....	103
Silicone Vegetable Parchment Release Paper.....	103
Smart Box™ Manufacturing Service.....	8
Smart Box™ Manufacturing Service.....	8
Smart Glass Sizer - reference.....	160
Smart Vertical Mountboard Cutting System.....	160
Snap off Blade Knives and Rotary Cutter.....	151
Sodium CMC P200G Wallpaper Adhesive.....	131
Solander Box.....	16
Solvent Bottles.....	125
Solvents, Chemicals and Cleaning Fluids.....	211
Sonic Weld.....	174
Sontara® Wipes.....	207
Sorbarix® Absorbing Cushions.....	187
Spatulas - Heated.....	162-163
Spatulas - Stainless Steel.....	125
Speck-Grabber.....	207
Spirabilia™ Book Cleaning Workstation.....	205
Spray Bottles.....	126
ST Leafcasting Machine.....	165
Steamy PR (Steam Generator).....	165
Sterling SMD Plan Drawer Range.....	235
Stitch in Timecare® Negative & Print Storage System.....	50
Storage & Transportation Bag.....	78-79
Storage Boxes.....	7-41
Storage Folders, Envelopes & Pockets.....	42-61
Storage Trays.....	39
Storage Tubes.....	40-41
Straight Edge (steel).....	154
Studio Furniture.....	239-240
Studio VX 200 Drawer Range.....	240
Superior Millboard™.....	112
Support Board.....	110, 111, 114, 117-120
Swivels For Fixing Stretched Canvases.....	148
Sympatex®.....	103
Synergex® Acid-Free, Non-Woven 100% Polyester.....	104
Syneronic A7 Non-ionic SR05 Solution.....	212
Synthetic Materials and Heat-Set Lamination.....	105
Syringes.....	125
Tags and Labels.....	139-140
Tapes.....	132-136
Teflon® PEFE Cloth.....	103
Temperature Meter - C-500 Temporary Exhibition & Photography Lux and Colour.....	199
Terms & Conditions.....	251-252
Testing Indicators.....	190-191
Testo Saveris™.....	192
Testo Saveris™ Base.....	193
Thermidity™.....	194
Thermo-hygrometer.....	197
Thermocutter.....	161
Time Capsules.....	184
Timecare® Age Compatible Toned Laid.....	87
Timecare® Channel Panel.....	120
Timecare® Coin & Medal Protectors.....	76
Timecare® Crystal Polyester Album Pages.....	69-72
Timecare® Heritage Conservation Board.....	113-114
Timecare® Heritage Museum Cotton Inlay Paper.....	86
Timecare® Heritage Museum Edition Paper.....	86
Timecare® Paper Honeycomb Panels.....	119
Timecare® Polypropylene Album Pages/Pockets, A4.....	85
Timecare® Ringbinder Boxes.....	17-20
Timecare® Ringbinder Dividers.....	76
Timelock™ Envelopes and Pockets - pHoton™.....	66
Tiny Tag Thermo-Hygrometer.....	196
Tiny Tag Ultra 2 (Dual Channel).....	195
Tinyview Plus.....	196
Tissue.....	63, 87
Tissue and Lightweight Papers.....	100
Torch - UV LED.....	229
Transparent Storage.....	68-81
Transparent Storage - reference.....	67
Trays - Premier™ Storage.....	39
Tru Vue®.....	149-150
Tweezers - Stainless Steel and Plastic.....	126
Tyvek® - Types 1443R, 1082D, 1073D, 1622.....	105
Tyvek® Tags.....	139
Tyvek® Tapes.....	133
Ultra Microfibre Cloth - White.....	207
Ultrasonic Humidification (see Humidity Control).....	188-190
V Mount Polyester Strips.....	137
Vacuum Bags.....	79
Vacuum Chamber Machines.....	185
Vacuum Cleaners - Conservation.....	200-203
Vacuum Impulse Sealer.....	186
Vacuum Tables.....	167-169
Vacuum-Sealing Machines.....	185-186
Visifiles™.....	49
Vivak® PETG plastic sheet.....	120
Wallets - Without Flaps (See also Enclosures and Pockets.....	48-514
Wallpaper.....	94
Washers.....	124
Washing Trays.....	126
Welding Machines.....	173-174
Workshop Furniture.....	239-240
Worktables.....	240

Full Product Listing

100% Cotton Gummed Paper Tape.....	132	Blue Wool Scales/Fade Indicator Card.....	190	Dehumidifier - WELLDRY 20 Model.....	189
1EC Heated Spatula with Tip Set.....	163	Bondina®.....	103	Dehumidifier Narcisco 16.....	188
1EM (Miniature) Heated Spatula.....	163	Bone Folders.....	125	Delimer Water-Softening Device.....	165
30 x Microscope Magnifier.....	221	Book Support Bags and Cushion Covers.....	144	Depulvera.....	205
4-Hole Punch.....	152	Bookbinders Starch Paste.....	129	Die-Cut Boxes, Flat-Packed for Self-Assembly or Ready-Assembled.....	9
4/4 Hanging Rod.....	147	Bookmark Strip.....	77	Discovery High-Security Drawer Cabinets.....	246
4E Heated Spatula.....	163	Box Assembly Methods.....	9	Dispenser and Adhesive.....	131
5000 DX Vocab - Room Air Cleaner.....	204	Bozone Gels.....	178	Display - Folder.....	75
5000 Exec UV - Archival Protection Systems.....	204	Bozone Sorb.....	190	Display Support.....	76
7 in 1 Bookbinding Table.....	158	Bracknell Soap.....	208	Display Support.....	76
7-Cell Porcelain Palette.....	125	Brass-Plated Washer.....	124	Disposable Foldable Comfort Model.....	213
8000 Series Reusable Protective Mask.....	213	Breva Eye Protection Goggles.....	214	Disposable Mask with Ventex Valve.....	214
Acid-Free Tissue Unbuffered.....	100	Bright Nylon Artist Brushes.....	217	DL100 Dermite, Magnified Inspection Light.....	228
Acrylic 'U' Shape Display Risers.....	146	Brother P-touch H105 Label-Maker.....	138	Double or Single-Sided Polyester Archival Tape.....	136
Acrylic 'Z' Shape Display Risers.....	146	Brushes with Metal Ferrule.....	218	Double-Crease Folder.....	45
Acrylic Book Stand 'Anti-Theft' Model.....	144	Buchanan High-Pressure Suction Point.....	167	Double-Face Conservation Mammoth.....	114
Acrylic Book Stand 'Crystal Display Easel' Model.....	145	Buckram Cloth 100% Cotton.....	136	Dow Corning Silicone Sealants.....	130
Acrylic Book Stand 'Crystal Flat' Model.....	144	Byron Weston Resistal Paper.....	87	Draft Clean - Granulated Eraser.....	209
Acrylic Book Stand 'Crystal Vertical' Model.....	144	C-500 Temporary Exhibition & Photography Lux & Colour Temperature Meter.....	199	Drawer Cabinets.....	245
Acrylic Book Stand 'Fold Away' Model.....	145	Capillary Matting.....	104	Dust and Mould Protection Face Mask.....	214
Acrylic Book Stand 'Open Book Rest' Model.....	144	Carbosorb™ Plus Face Mask.....	213	E Series Paper Pulpers 2-litre.....	166
Acrylic Book Stand 'Standard Flat' Model.....	144	Care Kits.....	209	Eco-Spray Micro-Diffuser.....	126
Acrylic Book Stand 'Visitor' Model.....	144	Carrousel Portfolio Box.....	15	EconoSpace®.....	148
Acrylic Drum.....	146	CD Storage Cases (not Corrosion Intercept®).....	19	EcopHant™ and Superior Millboard™.....	8
Acrylic Plate Display Cradle.....	146	CeelLite® LEC Flexible (1mm) Light Sheet.....	222	EcopHant™ Box and Lid.....	30
Acrylic Solid Blocks.....	146	Cellulose Powder.....	102	EcopHant™ Skull Box with Tray and Lid.....	38
Activated Charcoal Cloth®.....	107	Certificate Page.....	71	Edding 2000C Bullet-Tip and 2200C Chisel-Tip Permanent Markers.....	142
Adhesive Laminated Paper Board.....	109	Champlan™ Tilting Lightboxes.....	223	Edding 400/404 Bullet-Tip Permanent Markers.....	142
Ageless® Eye Oxygen-Indicating Tablets.....	181	Chartpak Roll Storage.....	41	Edding 751/780 Paint Marker.....	142
Ageless® Type ZPT.....	180	Chemically Resistant Synthetic Brushes.....	218	Edding 950 Industry Painter.....	142
Album Pages.....	72	Chinese Flexible Goat Hair Brushes.....	216	Electronic Noise-Cancelling Headsets.....	215
Aluminium Foil-Backed Archival Quality Adhesive Labels.....	139	Circus.....	226	Electronically-Operated Push-Button High-Security Drawer Cabinets.....	245
Aluminium Gas-barrier Tape 425.....	135	CL11 Indoor Air Quality Data-Logger.....	196	Elsec 765/765C.....	194
Aluminium Vapour Barrier Complex.....	107	Clarity by Larson Juhl, Waterwhite Anti-Reflective Glass.....	149	Escal Neo™ RP System, Ceramic-Deposited, Gas-Barrier Film.....	79
Aluminium Vapour-Barrier Complex.....	81,107	Clarkson Book Support System.....	143	Escal Neo™ System, Ceramic Deposited Gas Barrier Film.....	182
Anti-Static Cleaning Kit - only for glass.....	207	Clean Breeze III - Fume Source Capture.....	203	Ethaform®.....	119
Anti-Static Cloth.....	207	Cleaning Swab Sticks.....	207	Euro KD40 Plan Drawer Range.....	235
Anti-Theft 4/4 Hook.....	147	Cockroach, Silverfish and Crawling Insect Traps.....	177	Euro Pro A3 Cabinet.....	236
Anti-Theft 4/4 Hook Rod.....	147	Cokon™.....	104	Euro Pro Cabinet with 5 or 7 Drawers.....	236
Anti-Theft Head for 4/4 Rods.....	147	Cold Storage.....	66,230,231	Euro Pro CD/DVD Cabinet.....	236
Anti-Theft Key.....	147	Compact Noise-Cancelling Headset.....	215	Euro Pro Classique.....	237
Anti-UV Fluorescent Tube Sleeves.....	229	Concorde Aluminium Label-Holders with Self-Adhesive Backing.....	140	Euro Pro Continuous Handle.....	237
Aplix 800. Hook and Loop Self-Adhesive Nylon Coins & Tapes.....	135	Concorde Portfolio Box.....	15	Euro Pro High Capacity.....	237
AR Reflection-Free® Tru Vue® Glass.....	149	Conservac™ HEPA Vacuum - GS 555 Model.....	200	European Brushes Mop Brush.....	217
Archibond™ Tissue - Heat-Set.....	105	Conservation By Design Cold Storage.....	230	EVA03 Eye Protection Goggles.....	214
Archipress™ High Barrier Vacuum Pouches.....	80	Conservation Clear® Tru Vue® Glass.....	150	Evacon-R™ Conservation Adhesive.....	127
Archival Aids - Benzotriazole, Pure.....	211	Conservation-grade - UV Protection.....	150	EVApro Eye Protection Goggles.....	214
Archival Aids - British Museum Leather Dressing with Beeswax.....	208	Conservators' Choice Artist Quality Watercolours.....	123	Exhibition and Display Mounter.....	171
Archival Aids - British Museum Leather Dressing without Beeswax.....	208	Corn Starch Powder.....	128	Expanding Gusseted Folder.....	54
Archival Aids - Chemikit Paper Testing Kit.....	211	Corner Mounting Strips.....	137	ExpoCard™ Frame Backing Board.....	117
Archival Aids - Cleaning Solution.....	212	Corner-Rounder.....	152	Extra Large Hog Bristle Paint and Paste Brush.....	218
Archival Aids - Conservation Adhesive.....	128	Corrosion Intercept Technology™.....	19	Extra-Fine Lightweight Cross-Peen Hammer.....	148
Archival Aids - De-acidification (AADA) Solution.....	212	Corrosion Intercept Technology™ CD Jewel Case.....	19	Fabiano Copy Class 1.....	87
Archival Aids - Document Repair Tape.....	134	CORROSION INTERCEPT® Film and Bags.....	78,106	Fabiano Palatina Paper.....	87
Archival Aids - Epoxy Disintegrator.....	211	Corrosion Intercept® Film and Bags.....	106	Fan Call Ear Hair Brushes.....	217
Archival Aids - Lanolin, Anhydrous.....	208	Corrugated Boxboard.....	110	Felt-Tip Administration Pen.....	142
Archival Aids - Mobile De-acidification Spray Unit DA06.....	212	Costume Bag.....	78	Feutrex™ Polyester Felt.....	104
Archival Cloth™ with Texicryl Adhesive - Heat-Set.....	105	Cotton Gloves.....	215	Filmoplast P - Transparent.....	134
Archival Gummed Linen Hinging Tape.....	133	Cotton Linters Machine-Made.....	102	Filmoplast P90 - Opaque.....	134
Archival Pocket Envelopes with Non-Adhesive Flap.....	54	Cotton Tyng Tape Unbleached.....	135	Filmoplast SH, Self-Adhesive Cotton Fabric Tape.....	133
Archival Polypropylene Label-Holders with Paper Inserts.....	140	CP11 Indoor Air Quality Monitor.....	198	Filmoplast T Coloured Self-Adhesive Cotton Fabric Tapes.....	133
Archival Rag Endleaf 100% Cotton.....	85	Crepe Gum.....	210	Fine Point Kolinsky Sable Watercolour Brushes.....	218
Archival Self-Adhesive Labels.....	138	Criss Cross Heat-Sealing Machines Table Top Sealer for Polyethylene or Polyester.....	173	Flat 'Filbert' Squirrel Brushes.....	217
Area Bonded Fibre™ - Heat-Set.....	105	Criss Cross Power Pack.....	173	Flax Pulp Machine-Made.....	102
Art Gum Eraser.....	210	Criss Cross Remote Sealer.....	173	Flush Mount Probes.....	195
Artique Conservation SolidCore and Surface Colour.....	116	Criss Cross Remote Welding Jaws.....	173	Fluted Polypropylene Portfolio.....	59
Artline 883 CD/DVD Pen.....	141	Crystal Glassine Paper.....	100	FoamTech Series.....	156
Artsorb® sheets.....	189	Crystallizations Systems Inc (CSI) Lightweight Aluminium Picture Storage System.....	238	Foillatack™ Moisture Barrier Foamboard.....	118
Ashige-Kanamaki-Bake.....	220	Culminal® MC2000 Methylcellulose.....	131	Folder with Internal Envelope.....	46
B-173 Twin Cond.....	198	Dahlia Spray.....	164	Folding LED Linen Tester Magnifier.....	221
B-212 Twin pH Meter.....	198	Dami-Bake.....	220	Folding Linen Tester Magnifier.....	221
Bambi Compressor.....	169	Dancheck Film Indicators.....	191	for Polyethylene or Polyester.....	173
Bambule® Anti-Insect Spray.....	178	Data-Logger.....	197	Forged Steel Scissors.....	152
Bassaire Mobile Clean Air Conservation Work Station.....	205	Decorators Dusting Brushes A and B Types.....	216	Fountain Brush™.....	124
Belo - Illuminated Low-Pressure Table - Large-Format.....	168	Dehumidifier - Edenaar.....	188	Four-Flap Folder.....	56
Beva® 371.....	127	Dehumidifier - OD125/165.....	189	Four-Flap Single and Double-Crease Folders.....	58
Big Yella Bag™ and Transfolio™ Bag.....	79			Frame Sealing Tape.....	134
Binocular Magnifiers COMFORT Model.....	221				
Binocular Magnifiers STANDARD Model.....	221				

Frameorama™ Display Frame.....	246	L'Aura.....	206	Microscopes with Zoom.....	229
Fume Extraction Cabinet with Air Purifier.....	212	L1 Task Light.....	225	Nilfisk Brushes.....	202
Functions of RP Oxygen-Absorbing Scavenger Agent.....	181	Label Holders - Self-Adhesive.....	140	Nilfisk GD 5B Battery Backpack Vacuum.....	203
Gatorfoam®.....	119	Labels for Concorde Aluminium Label-Holders.....	140	Nilfisk GD1005.....	202
Glass Protection Tape.....	135	Laponite Gel.....	130	Nilfisk GD5VH Back Pack Cleaner.....	202
Glass-Top Display Drawers.....	245	Laponite Powder.....	130	Nilfisk GWD320.....	202
GM Character Laid and Wove.....	94	Large-Flap Folders.....	57	Nitrile Disposable Gloves.....	215
GM Handmade European Jute Tissue Paper.....	93	Large-Format Professional Trimmers with Stand.....	159	Non-Adhesive Laminated Paper Board.....	108
GM Handmade Lining Paper for Historic Wallpaper Reproduction.....	94	Larson Juhl Conservation Corner Mounts.....	136	Non-Archival Paper Swing Labels.....	139
GM Handmade Wallpaper for Historic Reproduction.....	94	Latex Gloves.....	215	Nori-Bake.....	219
GM Ledger Paper, Gelatine-Sized.....	93	Lead Weights.....	144	Norikoshi Sieve and Noribon Paste Bowl.....	129
Goldfinger Metallic Paste.....	123	LED 003 Vari-Beam Task Light.....	225	Notary Box.....	24
Grey PVC Washing Trays.....	126	Library Storage Boxes: archival boxboard, tabbed assembly.....	11	Nylon Cord.....	148
Griffen Mill Handmade Paper.....	93	Light Roof.....	228	OK Tissue.....	100
Groom/Stick.....	210	LightControl.....	191	Open-Top Expansion Wallets/Pockets Adhesive Flap.....	62
GS 555/777 Accessories.....	200	Lineco - Hayaku Gummed Japanese Paper Tape.....	132	Opera Portfolio Box.....	15
GS 777 Accessories.....	201	Lineco Mending Tissue.....	134	Orange - Silica Gel.....	190
GS 777 Model.....	201	Linen Bookbinding Cord.....	131	Original Curateur™ Polyester Edge Welder.....	174
Gummed Tyvek® Tape.....	133	Lining Irons.....	164	Overall.....	213
Hahnemühle Cylinder Mould-Made Laid Paper.....	87	LOG-HC2 Universal Data-Logger.....	194	Oxygen-Free Showcase.....	246
Hand Pump Spray Bottle.....	126	Long-Life Sterilised Wheat Starch Paste.....	129	P Series Paper Pulper.....	166
Handmade Cloth-Covered Boxes.....	9	Lost Head Nails.....	148	Paper and Leather pH Meter.....	198
Hanging Bar.....	51	Low-Barrier, Transparent Vacuum Bags.....	79	Paper Clips.....	140
Hanging Rails - U section.....	147	Lydamore Flat-Packed EcopHant™ Boxes.....	29	Paper Dryer.....	172
Hanna HI 97500 Model.....	199	Lydamore Upright Document Box.....	23	Paper Nao Japanese Handmade Paper.....	96
HC-5 Humidification Chamber.....	169	Magnifying Glasses.....	221	Paper Nao Japanese Machine-Made Paper Rolls.....	96
Heated Glass Vacuum Press.....	171	Magnifying Lamps FM 101 Model.....	226	Paper Sword Moisture Monitor.....	194
Heated Spatulas - Model Spater 10.....	162	Magnifying Lamps SN MODEL.....	226	Paraloid B72.....	128
Heated Spatulas - Spater 2 with Pre-programmable Bits.....	162	Manual Book Measure.....	176	Partitioned Boxes for Book Storage.....	14
Heated Spatulas - Spater 3.....	162	Map and Banner Bag, Calico.....	78	Paste Ring.....	129
Heated Spatulas - Spater 8.....	162	Maped™ Architect Eraser.....	210	Pasteless Bookbinders' Board.....	112
Heavy BeanBag™ Paperweights.....	124	Maped™ Cutting Heads.....	153	Pentel Click Eraser.....	210
Heavy-Duty Paper Block Cutting Guillotine.....	157	Maped™ Mat-Cutter System 80cm and 60cm.....	153	pHiClas™ Museum Collection Ringbinder album + slipcase.....	21
Herbarium Mounting Cartridge 100% Cotton.....	86	Maped™ Rulers - Prodeca.....	154	pHiClas™ Museum Collection Ringbinder Box.....	21
Heritage Acid-Free Blotting Paper.....	101	Maped™ Rulers - Profila.....	154	pHiClas™ Museum Collection Ringbinder Box.....	17
Heritage Archival pHotokraft™ Duke Parchment.....	84	Maped™ Rulers - Quadra.....	154	Photographic Marker Pencil.....	141
Heritage Archival pHotokraft™ Gummed Tape.....	132	Maped™ Rulers - Technic 600 Vinyl Eraser.....	210	pHoton™ 100% Cotton Envelope.....	51, 65
Heritage Archival pHotokraft™ Neutral Grey.....	84	Mechanical Pencil.....	141	pHoton™ 100% Cotton High-Purity Paper.....	42
Heritage Archival pHotokraft™ Old Grey Ivory.....	85	Medieval Dark Toned Laid Paper.....	87	pHoton™ Aqua-Forte - High Wet-Strength.....	101
Heritage Archival pHotokraft™ Paper.....	84	Megasorb™ 100% Cotton Extra Heavy Blotter.....	101	pHoton™ Bench Blot.....	102
Heritage Archival pHotokraft™ Swing Labels.....	139	Metal Presentation Boxes for PROSorb™ Pellets.....	189	pHoton™ Bench Blot.....	102
Heritage Archival pHotokraft™ Taupe.....	85	Micro-Mesh®.....	123	pHoton™ Concertina Folder.....	51
Heritage Archival pHotokraft™ White Buffered.....	84	Micro-Tips to fit 1EM Heated Spatula.....	163	pHoton™ Four-Flap Enclosures for Glass Plate and Film Negatives.....	64
Heritage Archival pHotokraft™ White Unbuffered.....	84	Microballoons.....	128	pHoton™ High-Purity Papers.....	89
Heritage Library Tape™.....	135	Microfibre Cloth - Yellow.....	207	pHoton™ High-Purity Papers.....	63
High-Accuracy Balance.....	199	Micrometers.....	154	pHoton™ Photographic Print Four-Flap Folder.....	65
High-Strength 11/4 Hanging Rod.....	147	Microprocessor-Controlled pH Meter.....	198	pHoton™ Roll.....	89
Holytex® Acid-Free Non-Woven 100% Polyester.....	104	Mini Pro V-300-HTK Conservation Vacuum Impulse Sealer.....	186	pHoton™ Sheets.....	89
Hooks for 11/4 Rods.....	147	Mini-Adhesive Tape Dispenser.....	131	pHoton™ Stitch in Timecare® Enclosures.....	50
Hooks for 4/4 Rods.....	147	Mini-dehumidifier.....	188	pHoton™ Timelock™ Adhesive-Free Negative Envelopes and Pockets.....	66
Hot Air Gun.....	164	Miniature Probes.....	195	Picture Storage System.....	238
Hot Knife.....	161	Mitsubishi Aluminium Foil Pouches.....	80	Pigma Micron Pens.....	141
Humidifier - LBV 45.....	188	Mitsubishi Aluminium Foil Pouches.....	184	Pink Legal Tape.....	135
Humidifier Defensor.....	188	Mizu-Bake.....	219	Pistal™ Anti Wood-Pest Spray.....	177
Humidity and Temperature Measurement.....	192	Mobile Compact Shelving.....	237	PlanoLux™.....	223
Humidity Indicator Cards.....	190	Mobile Dust Cleaner.....	204	Planorama® Drawers.....	233
HygroPalm 22-A Set.....	195	Moistop Barrier Foils.....	107	Planorama® Drying Rack.....	172
Ideal 0135 and 0155.....	155	Moistop Barrier foils.....	81, 107	Planorama® Glass-Top Cabinet and Display Drawers.....	245
Ideal Office Trimmer for A3/A4 - Automatic Clamp.....	157	Mop Cap Polypropylene Head Protection.....	213	Planorama® storage systems.....	66
Illuminated Vacuum Table, high or low-pressure.....	167	Moulin du Verger 100% Raw Flax and Linen Fibre.....	91	Plastazote® Foam.....	120
Insect and Pest Traps.....	177	Moulin du Verger CC2 Pasteless Cover Paper.....	92	Plastazote® Jumbo Boxes.....	9
Integrated - NTC Air Measurement.....	197	Moulin du Verger Decorative Cover paper.....	92	Plastic Art Brushes.....	218
Iroise Eye Protection Goggles.....	214	Moulin du Verger Gelatine-Sized MVM.....		Plastic Saucer Set with Cover.....	125
Iron-Gall Ink Testing Paper.....	191	Medieval-Style Wooden Stamper-Beaten paper.....	91	Plastic Syringes.....	125
Japanese Brushes.....	219	Moulin du Verger Handmade Paper Sample Book.....	91	Plastic Tweezers.....	126
Japanese Handmade Hinging Paper.....	132	Moulin du Verger Iris Endpapers.....	93	Plastigom Granulated Plastic Eraser.....	209
Japanese Nakasato Brush.....	216	Moulin du Verger Wet Laid Multi-Layered, Pasteless Bookbinders' Board.....	112	Pneumatic Paper Press.....	170
Japanese Paper - S13 Selection.....	96	Multirestor®.....	166	Pneumatic Vacuum Tables.....	168
Jin Shofu Paste.....	129	Multisorb™ 100% Cotton Highly Absorbent, Wet-strength Blotter.....	101	Polyester Cut Sheets.....	78
Kasemake CXD Digital Book Measure.....	176	Museum Glass® Tru Vue® Glass.....	149	Polyester Display Strips.....	137
Kataha-Bake.....	220	Museum Herbarium and Entomology Cabinets.....	239	Polyester Perforated Insertion Strip.....	51
Keencut Simplex™ Large-Format Cutter.....	156	Natural Clay.....	130	Polyester Rolls - Types 1 and 2.....	77
Keencut Ultimat Gold™ Mat-Cutting Machine.....	159	Natural Linen Tape.....	135	Polyethylene Washers.....	124
Kenair Air Duster.....	206	Natural Quill Watercolour Brushes.....	218	Polyid™ Lightweight Polypropylene Honeycomb Board.....	119
KI Anti-Static Brushes.....	216	Naze-Bake.....	219	PolypHlute™ - Textile Box.....	35
KI Anti-Static Gloves.....	215	Newsteo Tracker, Data Logger for Monitoring Transport History.....	199	PolypHlute™ Archives Box.....	26
Klucel G/E (Hydroxypropylcellulose).....	130	Nikon SMZ745 and SMZ445 Stereoscopic Microscopes with Zoom.....	229	PolypHlute™ Archives Plus Box.....	26
KnoOx™ 1000 Optical Oxygen Analyser System.....	184				
Kozo Tissue.....	99				

Full Product Listing

PolypHlute™ Container Box.....	32	Premier Duo™ PV Box.....	24	Shashi-Bake.....	220
PolypHlute™ Container Box.....	32	Premier Duo™ RG Box.....	25	Shelf Dummies.....	140
PolypHlute™ Corrugated Polypropylene + Polyethylene.....	8, 111	Premier Duo™ Short-Flap Folder.....	60	Shiro-Ebake.....	220
PolypHlute™ Disk Box.....	26	Premier Duo™ SL Metal-Edge Book End Box.....	40	Silicone Release Paper - Two-Sided.....	103
PolypHlute™ Documents Box.....	14	Premier Duo™ SP Metal-Edge Window Box.....	37	Silicone Vegetable Parchment Release Paper.....	103
PolypHlute™ Glass Plates Box.....	26	Premier Duo™ ST Model Box.....	33	Single-Crease Folder.....	44
PolypHlute™ Graphic Novels Box.....	26	Premier Duo™ STDI A Box.....	33	Single-Crease Folder for P-Boxes.....	44
PolypHlute™ Periodicals Box.....	14	Premier Duo™ STF Metal-Edge Window Box.....	38	Smart CMC Mount/Mat-Cutter.....	160
PolypHlute™ Rivets.....	111	Premier Duo™ STP Metal-Edge - Special for Photo Print.....	35	Smart Manual Mount/Mat-Cutter.....	160
PolypHlute™ Roll Box.....	41	Premier Duo™ SV Metal-Edge Box.....	35	Smart Mat Vertical Mount/Mat-Cutting System.....	160
PolypHlute™ Textile Box.....	35	Premier Duo™ Tabbed Box and Lid.....	31	Snap off Blade Knives and Rotary Cutter.....	151
Polypropylene Bags.....	77	Premier Duo™ Tabless Box and Lid.....	30	Sodium CMC Carboxymethyl Cellulose Gabrosa P200G.....	131
Polypropylene Sheets.....	78	Premier Duo™ Traditional Uncovered Portfolios.....	62	Solander Supreme Handmade Boxes.....	16
Polystyrene Paper Clips.....	140	Premier Duo™ Upright Document Boxes.....	23	Solvent Bottles.....	125
Porcelain Saucer Set with Cover.....	125	Premier Duo™ Upright Hinged-Lid Box.....	23	Sonic Weld.....	174
Portable Rolling Creaser.....	176	Premier Duo™ Wallpaper Sample Book Storage Box and Multi-Crease Wrapper.....	35	Sontara® Wipes.....	207
Pre-Lim Surface Cleaner.....	208	Premier Duo™ Wallpaper Sample Book Wrapper.....	46	Sorbarix® A20 Water Absorbing Cushions.....	187
Premier 'L' Wallet White.....	47	Premier Duo™ Window Box.....	37	Sorbarix® AOB Oil Absorbing Cushions.....	187
Premier Buckram Duo™ RG Metal-Edge Box.....	25	Premier Duo™ Wire-Stitched Box and Lid (standard).....	31	Special Selection Japanese Paper Collection.....	99
Premier Buckram Duo™ STP Metal-Edge Photo Box.....	34	Premier™ 'L' Wallet Grey.....	47	Speck-Grabber.....	207
Premier Duo™ 'Bookshoe' Boxboard - Solid Colour.....	110	Premier™ Archival Pocket Envelope with Flap.....	53	Spider's Wet-Strength Tarantula Tissue.....	100
Premier Duo™ 3D Metal-Edge Window Box.....	37	Premier™ Bookshoe Boxboard.....	110	Spirabilia™.....	205
Premier Duo™ Archival Flap Folder.....	55	Premier™ Envelope with Flap.....	53	ST Leafcasting Machine.....	165
Premier Duo™ Archival Fluted Boxboard.....	111	Premier™ Expanding Gusseted Pocket Envelope.....	54	ST Paper Press - Electro-Hydraulic.....	169
Premier Duo™ Archival Folding Boxboard - Solid Centre.....	110	Premier™ Fluted Boxboard.....	111	ST Paper Press - Manual.....	169
Premier Duo™ Archival Folding Solid Centre and Fluted/Corrugated Boxboard.....	7	Premier™ Four-Flap (Botanic Capsule) Folder.....	57	ST Paper Press - PR 36.....	170
Premier Duo™ Archival Single-Crease Folder.....	46	Premier™ Four-Flap Folders for Glass Plates.....	61	STAEDTLER Mars Plastic Eraser.....	210
Premier Duo™ Archival Textile Storage Box.....	28	Premier™ Large Flap Folders One-Piece.....	57	Stainless Steel Spatulas.....	125
Premier Duo™ Audio Cassette Box.....	33	Premier™ Map Folders.....	59	Stainless Steel Tweezers.....	126
Premier Duo™ Beaux Arts, Print and Drawing Folders.....	59	Premier™ Microfiche Topless Wallet.....	48	Standard Foamboard.....	118
Premier Duo™ BH Box.....	26	Premier™ Pocket Envelopes for CDs.....	53	Steamy PR.....	165
Premier Duo™ Book Storage Box.....	36	Premier™ Record Sleeves for 33, 45 and 78 rpm Vinyl Disks.....	50	Steel Straight Edge.....	154
Premier Duo™ Boxboard-Backed Pocket Envelopes.....	53	Premier™ Rollsafe's Storage Tubes.....	41	Sterling SMD Plan Drawer Range.....	235
Premier Duo™ Buckram - PM Box.....	14	Premier™ Topless Wallets and Pockets.....	48	Storage Trays.....	39
Premier Duo™ Carry Case With Handle.....	27	Premier™ Western Manuscript String and Washer Folder.....	60	Stouls Non-Woven Polyester.....	103
Premier Duo™ CD/DVD Box.....	25	Preservation Pencil® and Ultrasonic Humidifier.....	165	Stouls Satin Conservation SolidCore.....	115
Premier Duo™ Clam Self-Locking, Multi-Crease Folder.....	55	Primal (Rhoplex) Acrylic Dispersion (W524 and B60A).....	127	Stouls Single-Crease Folder.....	44
Premier Duo™ Cube Tubes™.....	40	Print and Newspaper-Boxes.....	28	Stouls Van Gelder Conservation SolidCore.....	115
Premier Duo™ D Box.....	33	Professional Trimmer Ideal - Manual Clamp.....	159	Studio Board Shear.....	157
Premier Duo™ Drop-Back Microfilm Boxes.....	13	Professional-Quality, Double-Door Refrigerator.....	231	Studio Luminaires.....	228
Premier Duo™ Drop-Spine Box - Tabless.....	13	Professional-Quality, Single-Door Photo Refrigerator.....	231	Studio Range - Worktables, Fixed and Height-Adjustable.....	240
Premier Duo™ Drop-Spine Photographic Boxes - Tabbed (P-Box System).....	12	PROSorb™ Humidity Control Systems.....	189	Studio Task Lamp STE 111.....	227
Premier Duo™ Duplex Envelope with Flap.....	52	Psychrometer.....	197	Studio Task Lamp STE136.....	227
Premier Duo™ ECL Ringbinder Album + Slipcase.....	21	PTS-Grade, Very High-Barrier, Pre-Formed Pouches.....	80	Studio VX 200 Heavy-Load Drawer Range.....	240
Premier Duo™ Expanding Book Wrapper.....	46	Pulvisina.....	206	Superior Millboard™.....	112
Premier Duo™ Fiche Box.....	24	Punch Kit.....	152	Surikomi-Bake.....	220
Premier Duo™ Flute Document Box.....	25	Pure Linen Strapping and Welded D Rings.....	148	SVDIA and CDIA Box.....	33
Premier Duo™ Flute Flip-Top Document Box.....	25	Purification Paint®.....	107	Swann-Morton Scalpels.....	151
Premier Duo™ Flute Periodicals Box.....	25	Quasar™ Lightboxes.....	223	Swivels For Fixing Stretched Canvases.....	148
Premier Duo™ Foamboard.....	118	React Pack Disaster Kit.....	187	Sympatex®.....	104
Premier Duo™ Four-Flap Folder - BT folder.....	59	Reactive Intercept Barrier System (RIBS) Foil.....	80,106	Synergex® Acid-free Non-Woven 100% Polyester.....	104
Premier Duo™ Four-Flap Folder - PR folder.....	61	Reactive Intercept® Barrier System (RIBS) Foil.....	80	Synperonic A7 Non-ionic SR05 Solution.....	212
Premier Duo™ Four-Flap Folder with Velcro® Fastener.....	56	Reemay® Non-Woven Synthetic Fabric.....	104	Tako-Bake.....	220
Premier Duo™ Heavy Duty Library, Print and Newspaper Boxes.....	28	Renaissance Metal De-Corroder.....	208	Task Lighting.....	225
Premier Duo™ Heritage Archival pHotokraft™ Paper.....	42	Renaissance Wax Polish.....	208	Teflon® 'Bone' Folders.....	125
Premier Duo™ Hinged Lid Glass Plate Negative, Microfiche, Postcard and CD Storage Box.....	22	Reproduction.....	94	Teflon® PEFE Cloth.....	103
Premier Duo™ Laminated Paper and Board.....	42	Rice Starch Powder.....	129	Tengu 2gsm Natural Shade Kozo Tissue.....	99
Premier Duo™ Large Storage and Transit Box and Lid.....	32	Riveting Machine and Matrices.....	123	Testo 174H Mini Data-Logger, Dual-Channel.....	196
Premier Duo™ LH Box.....	25	Riveting Presses.....	176	Testo 175H1, Dual-Channel Temperature and Humidity Data Logger.....	197
Premier Duo™ Library Wire Stitched Drop-Spine Box.....	13	Riveting Punch.....	123	Testo Infrared Thermometer - Laser Sighting and Integrated NTC Air Measurement.....	197
Premier Duo™ Magazine/Pamphlet Boxes.....	39	Roll Storage.....	237	Testo Mini Light Meter - 540.....	199
Premier Duo™ Metal-Edge Film Box.....	35	Roller Base Luxo Model.....	228	Testo Saveris™.....	192
Premier Duo™ Metal-Edge Microfiche Box.....	34	Rotatrim PowerTech Series.....	156	Testo Saveris™ Base.....	193
Premier Duo™ Metal-Edge Microfiche Box.....	34	Rotatrim Professional M Series.....	155	Testo Saveris™ Base.....	193
Premier Duo™ Metal-Edge Tube Box.....	41	Rotatrim Technical Series.....	156	Testo Saveris™ Logiciel.....	193
Premier Duo™ Metal-Edge Video Cassette Box.....	34	Round Nylon Artist Brushes.....	217	Testo Saveris™ Radio probes T°.....	193
Premier Duo™ MH Metal-Edge Window Box.....	38	Rowney Kneadable Rubber.....	209	Testo Saveris™ Radio probes T° and HR.....	193
Premier Duo™ MICROBOX.....	39	RP Oxygen-Absorbing Scavengers.....	180	Testo Saveris™ Router.....	193
Premier Duo™ NG Box.....	24	RP System™ Type A.....	180	Tevisio LED Magnifier Luminaire.....	227
Premier Duo™ Open-Top File Box.....	39	RP System™ Type K.....	180	Texicryl™ Acrylic Emulsion.....	127
Premier Duo™ Palm Leaf Storage Box Wrapper.....	36	S Series Paper Pulper.....	166	Textile Moth-Repellent Vaporising Card.....	177
Premier Duo™ Partitioned Box.....	14	Schimanek Heavy-Duty Guillotine.....	158	Textile Mothproof Spray.....	177
Premier Duo™ pHase 3™ Folder-Box.....	56	Schott KL 200.....	224	The Conservation Bookmate™ Companion Set.....	143
Premier Duo™ pHlip™ Top Microfilm Boxes.....	23	Schott KL1500 LED.....	224	The CXD Smart Box™ Manufacturing Service.....	8
Premier Duo™ PM Box.....	14	Scissors.....	152	The Kasemake CXD Library and Archive - Boxmaking System.....	175
Premier Duo™ Postcard Box.....	34	See-Thru Polyester Mounting Strips.....	136	The Original Japanese Screw Punch.....	153
		Self-Adhesive Backing.....	140	Thermidity™.....	194
		Self-healing PVC Cutting Mats.....	151	Thermo-hygrometer.....	197
		Semi-Matic Laminators.....	170	Thermocutter.....	161

Time Capsule.....	184	Volara® (acid-free) Foam Rabbit Tape	134
Time Capsule For Britain's Oldest Dance Company.....	184	Vulcanised Smoke Sponge.....	209
Timecare® Acid-Free Mounting Paper Inserts.....	85	Vulpex Liquid Soap.....	209
Timecare® Age Compatible™ Toned Laid	87	Wallpaper Adhesive.....	131
Timecare® Box Populi Ringbinder.....	20	Wave LED.....	226
Timecare® Carry Cube	32	Wax 213 - Colourless.....	208
Timecare® Cerificate Ringbinder Box.....	18	Wet-Strength Blotter	101
Timecare® Channel Panel™	120	Wexford Applicator.....	130
Timecare® Coin & Medal Protectors.....	76	Wheat Starch Powder	128
Timecare® Connoisseur Ringbinder Box.....	17	Whisper Tissue™ Re-Moistenable Starch-Coated	
Timecare® Crystal Paperback:		Japanese Koza Tissue.....	99
170gsm PHIPAP Display Sleeve	75	White Polyethylene Washing Trays.....	126
Timecare® Crystal Paperback:		Willard Heated Spatulas - Heated Spatulas and Lining Irons..	163
350gsm PHICART Display Support	76	Wishab Sponge Erasers.....	209
Timecare® Crystal Paperback:		Wood 'Bone' Folders.....	125
400gsm PHIDOS Display Folder	75	Wooden Book Stand 'Closed Book' Model.....	145
Timecare® Crystal Paperback:		Wooden Book Stand 'Incunable' Model.....	145
830gsm PHIDOC Display Support	76	Wooden Book Stand 'Prestige' Model.....	145
Timecare® Crystal Polyester Type 1 A2 Album Pages.....	72	Wool Moth Traps.....	177
Timecare® Crystal Polyester Type 1 A4, Foolscap and A3		Wurth Neutral Curing Silicone Sealant.....	130
Timecare® Crystal Polyester Type 1: Storage Pockets	73	Yuki Flakes™, Ready-Cooked Japanese Tapioca Starch.....	129
Timecare® Crystal Polyester Type 2.....	77		
Timecare® Crystal Polyester Type 2: Storage Pockets.....	75		
Timecare® Crystal Polyester Type 2: Album Pages - A3.....	71		
Timecare® Crystal Polyester Type 2: Album Pages - A4.....	69		
Timecare® Crystal Polyester Type 2: Album Pages -			
BirthCertificate Page.....	71		
Timecare® Crystal Polyester Type 2: Album Pages - Foolscap.	71		
Timecare® Crystal Polyester Type 2: Album Pages - Prestige ..	72		
Timecare® Heritage Conservation SolidCore	114		
Timecare® Heritage Cotton Inlay Paper.....	86		
Timecare® Heritage Museum CottonCore	113		
Timecare® Heritage Museum Edition.....	86		
Timecare® Heritage Museum Mammoth.....	114		
Timecare® Library CD120 Ringbinder Box System.....	19		
Timecare® Library Ringbinder Box	18		
Timecare® Museum Portfolio Box.....	17		
Timecare® Museum Ringbinder Box.....	20		
Timecare® Paper Honeycomb Panels	119		
Timecare® Polyester HCL Album Pages.....	69		
Timecare® Ringbinder Dividers.....	76		
Tiny Tag Ultra 2 (Dual Channel).....	195		
Tinytag Thermo-Hygrometer	196		
Tinyview Plus.....	196		
Transport History.....	199		
Triangle PET Museum Mounting Corners.....	136		
Trigger-Spray Bottle.....	126		
Triptych Folder.....	45		
Tru Vue® Optium® Museum Acrylic -			
Conservation-grade UV Protection	150		
Tru Vue® Premium Glass Cleaner®.....	149		
Tsukemawashi-Bake.....	219		
Two-Part Cap Rivets.....	124		
Two-Part Compression Rivet.....	124		
Tylose MH300P.....	130		
Tyvek® 1073D	105		
Tyvek® Fabric Type 1622.....	105		
Tyvek® Self-Adhesive Tape.....	133		
Tyvek® Swing Labels and Tags.....	139		
Tyvek® Types 1443R and 1082D.....	105		
Uchi-Bake Japanese Pounding Brush.....	219		
Ultra Microfibre Cloth - White.....	207		
Unbuffered Conservation Board.....	114		
Uni Pin Ultra-Fine Water and Fade-Resistant Pigment Pens..	141		
Uni Power Tank Eco Ballpoint Pen for Wet Paper.....	141		
Uni Super Ink, Oil-based Permanent Pigment Marker	142		
Using Escal Neo™ and the RP System™.....	182		
UV Crystal Anti-UV Adhesive Polyester Film.....	229		
UV LED Torches.....	229		
V Mount Polyester Strips.....	137		
Vacuum Chamber Machine Options.....	185		
Vacuum Chamber Machines.....	185		
Vacuum Impulse Sealer	186		
Vacuum-Sealing Machines.....	185		
Vinyl Gloves.....	215		
Visifiles™ Transparent Matt Polypropylene			
Plan Drawer and Artwork Folders	49		
Vista Model	227		
VISTA Portable UV Light Inspection Magnifier	229		
Vivak® Plastic Sheet	120		

Tolerances and advice on ordering Solander Boxes

The manufacture of Solander Boxes is a handmade process where small variations in the materials used make it impossible to work to engineering tolerances. To help avoid problems or disappointment we advise the following tolerances and procedure be taken when specifying a special size of box.

Unless otherwise specified we will always add 12mm to any object size given i.e. 512 x 712mm internal box size for a 500 x 700mm object size. This allows for variations in the materials used in the construction of the box and possible variations in size and squareness of your object. If requested by you the minimum we will add to your object size will be 6mm on each dimension i.e. 506 x 706mm internal box size for a 500 x 700mm object size.

When ordering please specify the following:

- A.** The size of the object that the box will contain.
- B.** The internal size of the box bearing in mind the tolerances stated above. If closer tolerances are required we are happy to discuss the alternatives which may involve a different method of construction and having the object or a dummy, around which the box can be built.

- C.** The maximum external size of the box. This is important if the box has to fit a specific size of bay or shelf. Having this information is useful because it may not be possible to give the internal size required if the maximum external size is too small. Hopefully an expensive mistake can be avoided and an alternative style of box or storage solution can be recommended.

- D.** If you intend to store polyester pockets or sleeves within the boxes please ensure you allow enough tolerance between the object size and the polyester storage enclosure. This will vary according to the thickness and size of the object so it is hard for us to recommend a standard tolerance. For example a thin photograph may only need 6mm adding on each dimension where a thicker item such as a mounted item say 5mm thick may need 12mm adding depending on preference. Please take this only as a guide as we cannot be responsible for this decision and you must satisfy yourself that the enclosure is large enough for the object and that ease of insertion meets your requirements.



CAMI CONSERVATION 2014 specifieke verkoopvoorwaarden

- alle prijzen zijn exclusief BTW (21%) – zonder verbintenis
- als basis gelden de algemene verkoopvoorwaarden van Cami (zie Cami prijslijst)
- **prijzen:**
 - prijzen: zoals vermeld in de prijslijst
 - levering: franco aan huis vanaf €250 (mag samen met andere Cami producten, indien samen geleverd)
 - leveringstermijn : circa 4 weken (onder voorbehoud)
- **Cami catalogus** voor volgende producten:
 - museumkarton, passe-partoutkarton (Moorman, Peterboro & Hampton)
 - UV-werend glas, ontspiegeld glas, Optium (TruVue), Plexiglas
 - producten van Lineco, Filmoplast
 - passe-partoutmachines, cutting mats, ATG tape

CAMI CONSERVATION 2014 conditions spécifiques de vente

- prix hors TVA (21%) – sans engagement
- les conditions générales de vente en vigueur sont celles reprises dans le tarif de Cami
- **prix:**
 - prix: comme dans le tarif
 - livraison: franco domicile à partir de €250 (éventuellement avec d'autres produits Cami)
 - délai de livraison: environ 4 semaines (sous réserve)
- **catalogue Cami** pour les articles suivants:
 - carton musée, carton contre-collé (Moorman, Peterboro & Hampton)
 - verre anti-UV, verre anti-reflet, Optium (TruVue), Plexiglas
 - produits de Lineco, Filmoplast
 - machines à passe-partout, plaques de coupe, ruban adhésif ATG

prijslijsten & PDF catalogi :

www.cami-nv.com/conservation
login: Cami-conservation
paswoord: Cami-1982

info: info@cami-nv.com
bestellingen: orders@cami-nv.com

tarifs & catalogues (PDF):

www.cami-nv.com/conservation
login: Cami-conservation
mot de passe: Cami-1982

renseignements: info@cami-nv.com
commandes: orders@cami-nv.com

cami_{n.v.}

Edward Vlietinckstraat 8 - B-8400 Oostende - Tel: -32-(0)59-708666 - Fax: -32-(0)59-806867
info@cami-nv.com - www.cami-nv.com